

# PREFACE

This Service Manual describes the technical features and servicing procedures for the **KYMCO Skytown 125**

Section 1 contains the precautions for all operations stated in this manual. Read them carefully before starting any operation.

Section 2 is the removal/installation procedures for the frame covers, which are subject to higher removal/installation frequency during maintenance and servicing operations.

Section 3 describes the inspection/adjustment procedures, safety rules and service information for each part, starting from periodic maintenance.

Sections 6 through 17 give instructions for disassembly, assembly and inspection of engine, chassis frame and electrical equipment.

Most sections start with an assembly or system illustration and troubleshooting for the section. The subsequent pages give detailed procedures for the section.

**Our company reserves the right to make any alteration in the design. The information and contents included in this manual may be different from the motorcycle in case specifications are changed.**

**KWANG YANG MOTOR CO., LTD.**  
**QUALITY TECHNOLOGY DEPARTMENT**  
**EDUCATION SECTION**

## TABLE OF CONTENTS

GENERAL INFORMATION	1
FRAME COVERS/EXHAUST MUFFLER	2
INSPECTION/ADJUSTMENT	3
LUBRICATION SYSTEM	4
FUEL SYSTEM	5
ENGINE REMOVAL/INSTALLATION	6
CYLINDER HEAD/VALVES/PISTON	7
DRIVE AND DRIVEN PULLEYS/KICK STARTER	8
FINAL REDUCTION	9
STEERING HANDLEBAR/FRONT WHEEL/FRONT BRAKE/FRONT SHOCK ABSORBER/FRONT FORK	10
REAR WHEEL /REAR BRAKE /REAR SUSPENSION	11
BATTERY /CHARGING SYSTEM	12
IGNITION SYSTEM	13
STARTING SYSTEM	14
LIGHTS/INSTRUMENTS/SWITCHES	15
EVAPORATIVE EMISSION CONTROL SYSTEM	16

# 1. GENERAL INFORMATION

# 1

ENGINE SERIAL NUMBER .....	1- 1	LUBRICATION POINTS.....	1-15
SPECIFICATIONS.....	1- 2	CABLE & HARNESS ROUTING.....	1-17
SERVICE PRECAUTIONS .....	1- 3	TROUBLESHOOTUNG.....	1-20
TORQUE VALUES .....	1-11		
SPECIAL TOOLS .....	1-12		

## ENGINE SERIAL NUMBER

Location of Frame Serial Number



Location of Engine Serial Number

# 1. GENERAL INFORMATION

## SPECIFICATIONS

Name & Model		Skytown 125	
Overall length (mm)		1940	
Overall width (mm)		750	
Overall height (mm)		1340	
Wheel base (mm)		1320	
Engine type		Air cooled 4-stroke	
Fuel Used		92# nonleaded gasoline	
Displacement (cc)		125cc	
Net weight (kg)	Front wheel	54	
	Rear wheel	72	
	Total	126	
Max weight Capacity (kg)	Front wheel	93	
	Rear wheel	183	
	Total	276	
Tires	Front wheel	110/70-14	
	Rear wheel	130/70-13	
Ground clearance (mm)		135	
Min. turning radius (mm)R/L		2000	
Starting system		Starting motor	
Fuel type		Gasoline, 4-stroke motor oil	
Cylinder arrangement		Single cylinder, flat	
Combustion chamber type		Semi-sphere	
Valve arrangement		O.H.C.	
Bore x stroke (mm)		φ52.4 X 57.8	
Compression ratio		11	
Compression pressure (kg/cm <sup>2</sup> rpm)		15kg/cm <sup>2</sup>	
Max. output		8.2kw/8500rpm	
Max. torque (NM/rpm)		10.6 N.M/6500rpm	
Port timing	Intake	Open	2°
		Close	28°
	Exhaust	Open	28°
		Close	-6°
Valve clearance		Intake	0.10mm
		Exhaust	0.10mm
Idle speed (rpm)		1600	
Lubrication type		centrifugal type	
Lubrication oil capacity (liter)		0.9L	
Exchanging capacity		0.8L	
Air cleaner type & No.		Wet, single	
Gear Oil capacity		0.13L	
Exchanging capacity		0.11L	
Fuel capacity (liter)		7.0L	
Carburetor	Type	—	
	Piston dia. (mm)	—	
	Venturi dia. (mm)	—	
Ignition system type		ECU	
Ignition timing F mark		—	
Spark plug		NGK	LR7D
Spark plug gap (mm)		0.6~0.7	
Battery capacity		12V 7AH	
Power to transmission gear		Power-transmission gear-clutch	
Reduction ratio of power to transmission		—	
Clutch type		Dry multi-disc clutch	
Transmission gear operation type		Automatic centrifugal type	
Transmission ratio		1 speed	—
Reduction gear	Type	Two-stage reduction	
	1st reduction ratio	0.87—2.70	
	2nd reduction ratio	10.25	
Transmission gear type		Non-stage transmission	
Tire pressure (kg/cm <sup>2</sup> )	Front wheel	1.75 kg/cm <sup>2</sup>	
	Rear wheel	2.0/2.25 kg/cm <sup>2</sup>	
Turning angle		Right43° & left 43°	
Brake system type	Front wheel	Disk	
	Rear wheel	Disk	
Suspension type	Front wheel	Telescope	
	Rear wheel	Unit swing	
Shock absorber type	Front wheel	Telescope	
	Rear wheel	Unit swing	
Frame type		Pipe under bone	

# 1. GENERAL INFORMATION

## SERVICE PRECAUTIONS

- Make sure to install new gaskets, O-rings, circlips, cotter pins, etc. when reassembling.

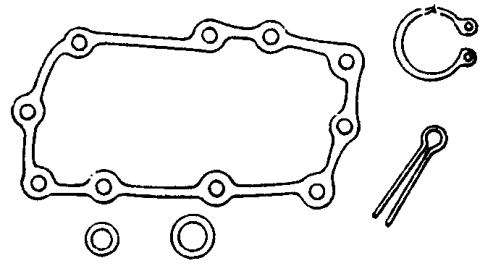

- When tightening bolts or nuts, begin with larger-diameter to smaller ones at several times, and tighten to the specified torque diagonally.

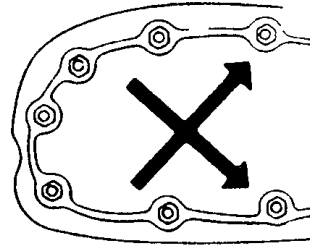

- Use genuine parts and lubricants

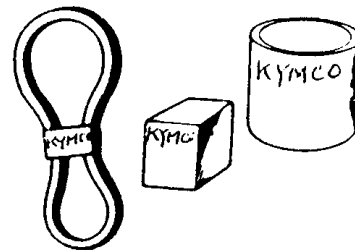

- When servicing the motorcycle, be sure to use special tools for removal and installation.

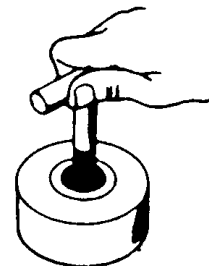

- After disassembly, clean removed parts. Lubricate sliding surfaces with engine oil before reassembly.

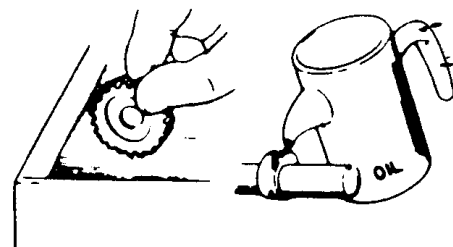



# 1. GENERAL INFORMATION

- Apply or add designated greases and lubricants to the specified lubrication points.

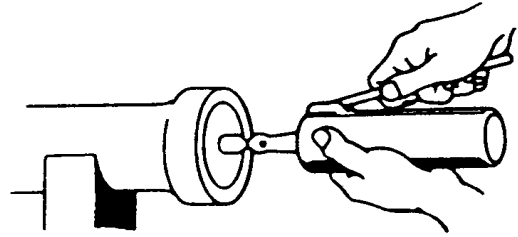

- After reassembly, check all parts for proper tightening and operation.

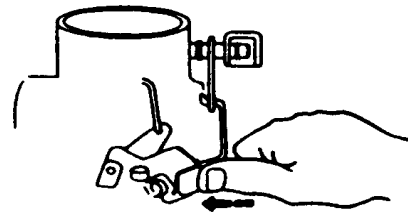

- When two persons work together, pay attention to the mutual working safety.

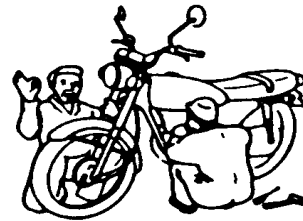

- Disconnect the battery negative (-) terminal before operation.
- When using a spanner or other tools, make sure not to damage the motorcycle surface.

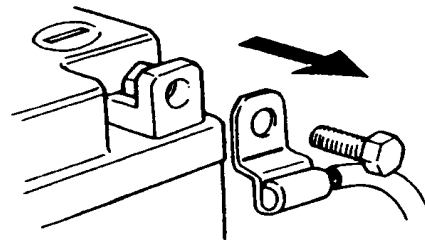

- After operation, check all connecting points, fasteners, and lines for proper connection and installation.
- When connecting the battery, the positive (+) terminal must be connected first.
- After connection, apply grease to the battery terminals.
- Terminal caps shall be installed securely.

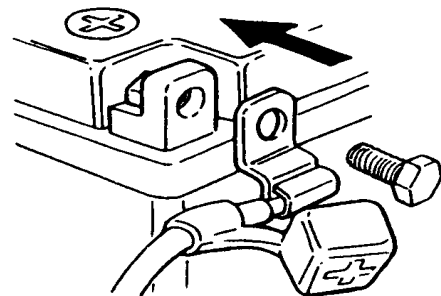

# 1. GENERAL INFORMATION

- If the fuse is burned out, find the cause and repair it. Replace it with a new one according to the specified capacity.

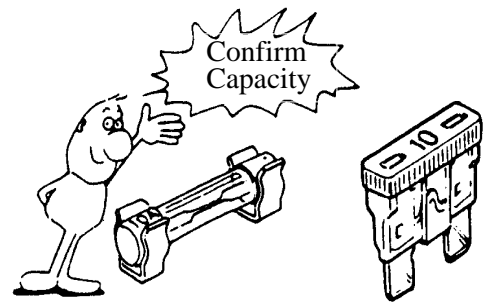

- After operation, terminal caps shall be installed securely.

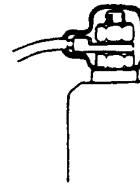

- When taking out the connector, the lock on the connector shall be released before operation.

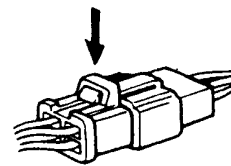

- Hold the connector body when connecting or disconnecting it.
- Do not pull the connector wire.



- Check if any connector terminal is bending, protruding or loose.

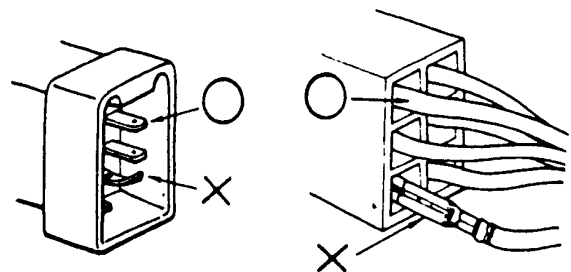

# 1. GENERAL INFORMATION

- The connector shall be inserted completely.
- If the double connector has a lock, lock it at the correct position.
- Check if there is any loose wire.

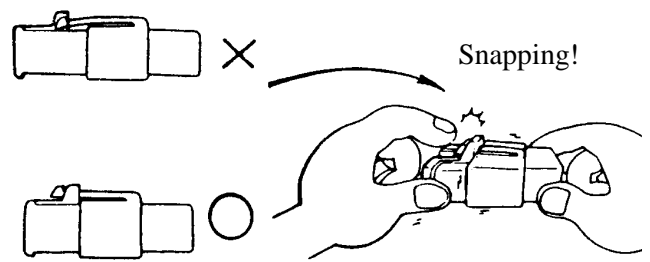

- Before connecting a terminal, check for damaged terminal cover or loose negative terminal.

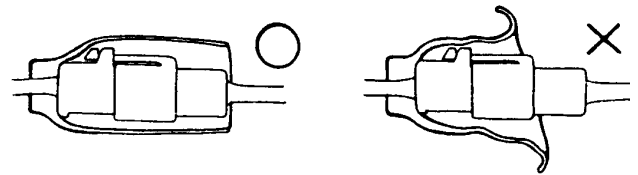

- Check the double connector cover for proper coverage and installation.

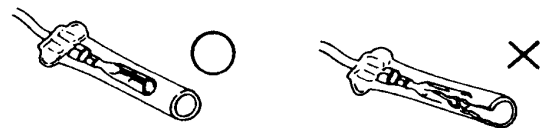

- Insert the terminal completely.
- Check the terminal cover for proper coverage.
- Do not make the terminal cover opening face up.

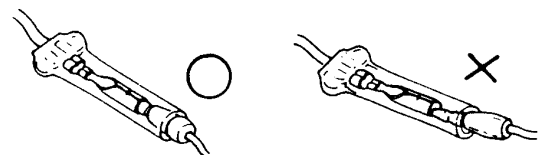

- Secure wire harnesses to the frame with their respective wire bands at the designated locations. Tighten the bands so that only the insulated surfaces contact the wire harnesses.

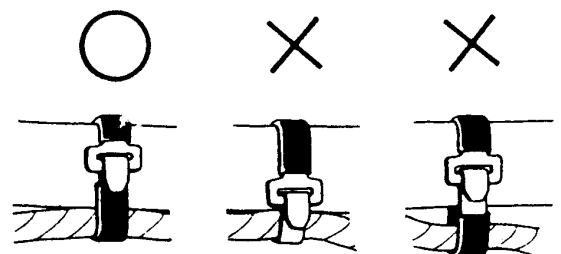

# 1. GENERAL INFORMATION

- After clamping, check each wire to make sure it is secure.

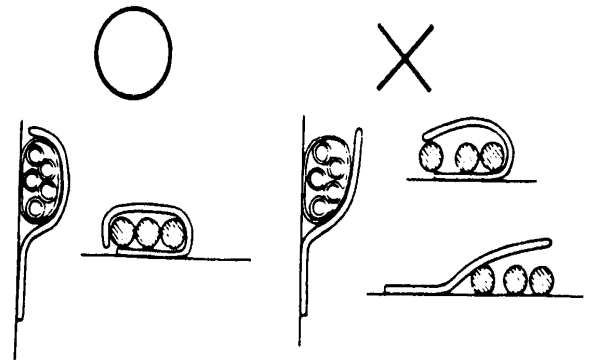

- Do not squeeze wires against the weld or its clamp



- After clamping, check each harness to make sure that it is not interfering with any moving or sliding parts.

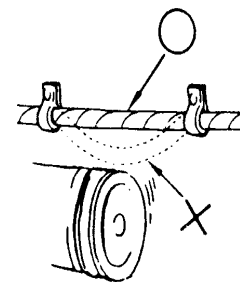

- When fixing the wire harnesses, do not make it contact the parts, which will generate high heat.

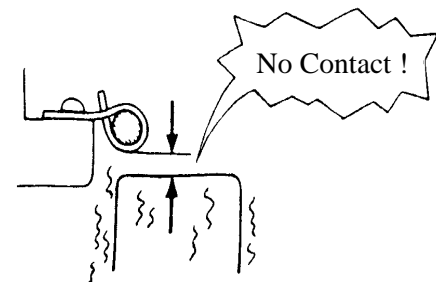

- Route wire harnesses to avoid sharp edges or corners. Avoid the projected ends of bolts and screws.
- Route wire harnesses passing through the side of bolts and screws. Avoid the projected ends of bolts and screws.

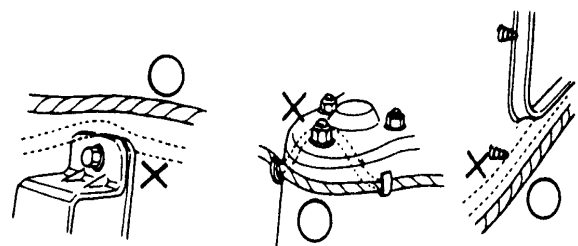

# 1. GENERAL INFORMATION

- Route harnesses so they are neither pulled tight nor have excessive slack.

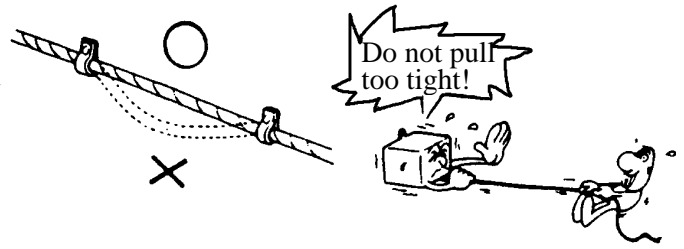

- Protect wires and harnesses with electrical tape or tube if they contact a sharp edge or corner.

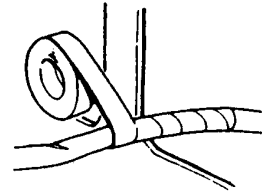

- When rubber protecting cover is used to protect the wire harnesses, it shall be installed securely.

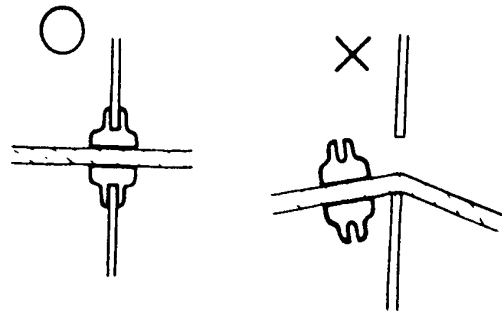

- Do not break the sheath of wire.
- If a wire or harness is with a broken sheath, repair by wrapping it with protective tape or replace it.

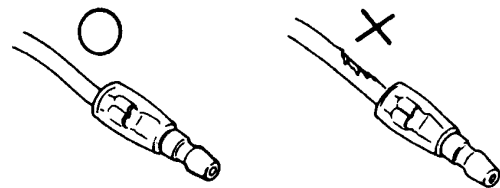

- When installing other parts, do not press or squeeze the wires.

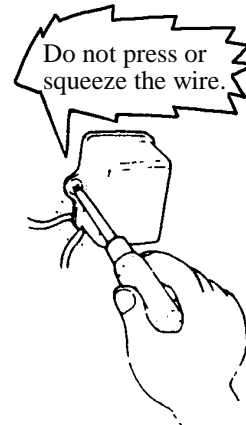

# 1. GENERAL INFORMATION

- After routing, check that the wire harnesses are not twisted or kinked.

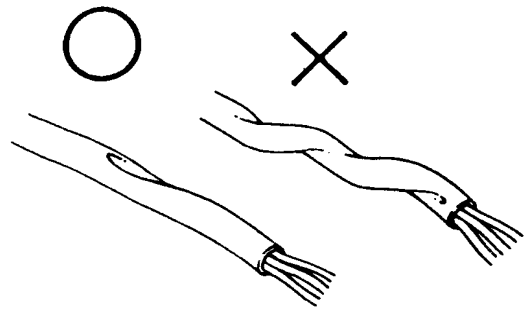

- Wire harnesses routed along with handlebar should not be pulled tight, have excessive slack or interfere with adjacent or surrounding parts in all steering positions.

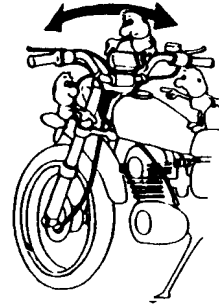

- When a testing device is used, make sure to understand the operating methods thoroughly and operate according to the operating instructions.

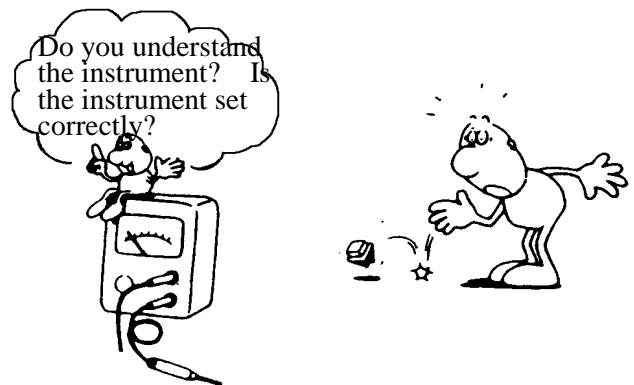

- Be careful not to drop any parts.

- When rust is found on a terminal, remove the rust with sand paper or equivalent before connecting.

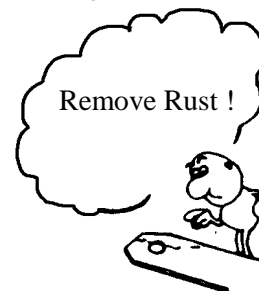

- Do not bend or twist control cables. Damaged control cables will not operate smoothly and may stick or bind.

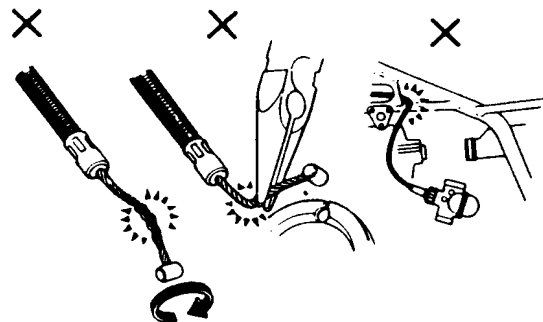

# 1. GENERAL INFORMATION

---

## ■ Symbols:

The following symbols represent the servicing methods and cautions included in this service manual.



Engine Oil

: Apply engine oil to the specified points. (Use designated engine oil for lubrication.)



Grease

: Apply grease for lubrication.



Gear Oil

: Transmission Gear Oil (90#)



: Use special tool.



: Caution



: Warning

# 1. GENERAL INFORMATION

## TORQUE VALUES

### STANDARD TORQUE VALUES

Item	Torque (kg-m)	Item	Torque (kg-m)
5mm bolt, nut	0.45-0.6	5mm screw	0.35-0.5
6mm bolt, nut	0.6-1.2	6mm screw, SH bolt	0.7-1.1
8mm bolt, nut	1.8-2.5	6mm flange bolt, nut	1.0-1.4
10mm bolt, nut	3.0-4.0	8mm flange bolt, nut	2.4-3.0
12mm bolt, nut	5.0-6.0	10mm flange bolt, nut	3.5-4.5

Torque specifications listed below are for important fasteners.

### ENGINE

Item	Q'ty	Thread dia.(mm)	Torque (kg-m)	Remarks
Cylinder head bolt A	2	6	0.7-1.1	Double end bolt
Cylinder head bolt B	4	6	0.7-1.1	
Oil filter screen cap	1	30	1.0-2.0	
Exhaust muffler lock bolt	2	6	0.7-1.1	Double end bolt
Cylinder head flange nut	4	7	1.2-1.6	Apply oil to threads
Valve adjusting lock nut	2	3	0.07-0.09	
Cam chain tensioner slipper bolt	1	8	0.4-0.7	
Oil bolt	1	8	1.1-1.5	
Clutch outer nut	1	10	3.5-4.5	
Clutch drive plate nut	1	28	5.0-6.0	
Starter motor mounting bolt	2	6	0.8-1.2	
Oil pump bolt	3	4	0.1-0.3	
Drive face nut	1	10	5.5-6.5	
Spark plug	1	10	1.0-1.4	
A.C. generator stator bolt	2	6	0.8-1.2	
Cam chain tensioner bolt	1	6	0.8-1.2	





### FRAME

Item	Q'ty	Thread dia.(mm)	Torque (kg-m)	Remarks
Steering stem lock nut	1	BC1	6.0-8.0	U-nut
Steering handle post nut	1	10	4.0-5.0	U-nut
Front axle nut	1	12	5.0-7.0	U-nut
Rear axle nut	1	16	11.0-13.0	U-nut
Rear shock absorber upper bolt	1	10	3.5-4.5	
Rear shock absorber lower bolt	1	8	2.4-3.0	
Muffler Bracket/ Rear Fork	1	8	3.0-3.6	
Rear Fork/Engine Case	1	8	2.4-3.0	Flange bolt
Engine Hanger---Frame side	2	10	4.5-5.5	
Engine Hanger---Engine side	2	10	4.5-5.5	U-nut



# 1. GENERAL INFORMATION

## SPECIAL TOOLS



Description	Tool No.	Photo
Flywheel puller	A120E00002	
Oil seal and bearing installer	A120E00014	
Universal holder	A120E00017	
Flywheel holder	A120E00021	
Clutch spring compressor	A120E00034	
Valve adjuster	A120E00036	
Bearing puller	A120E00037	
Cylinder Compression Gauge	A120E00039	

# 1. GENERAL INFORMATION

Description	Tool No.	Photo
Valve spring compressor	A120E00040	
Fuel Pressure Gauge	A120E00048	
INJECTOR CLEANER for Synerjet	A120E00075	
Wires Injector Connector	A120E00090	
Lock nut wrench	A120F00002	
Lower/Upper Race Remover & Installer	A120F00008	
Steering Stem Top Thread Wrench (shoter type)	A120F00024	
Steering Stem Top Thread Wrench	A120F00029	
Band Remover/Installer	A120F00030	

# 1. GENERAL INFORMATION

---

Description	Tool No.	Photo
Pliers Fuel Pipe	A120F00031	
Electric Repair Kit	A120F00032	

# 1. GENERAL INFORMATION

---

## LUBRICATION POINTS

### ENGINE

Lubrication Points	Lubricant
Valve guide/valve stem movable part Cam lobes Valve rocker arm friction surface Cam chain Cylinder lock bolt and nut Piston surroundings and piston ring grooves Piston pin surroundings Cylinder inside wall Connecting rod/piston pin hole Connecting rod big end Crankshaft R/L side oil seal Starter reduction gear engaging part Countershaft gear engaging part Final gear engaging part Bearing movable part O-ring face Oil seal lip	<ul style="list-style-type: none"> <li>•Genuine KYMCO Engine Oil (SAE15W-40)</li> <li>•API-SL Engine Oil</li> </ul>
Starter idle gear Friction spring movable part/shaft movable part Shaft movable grooved part Kick starter spindle movable part	High-temperature resistant grease
A.C. generator connector Transmission case breather tube	Adhesive

# 1. GENERAL INFORMATION

---

## FRAME

The following is the lubrication points for the frame.

Use a general purpose grease for parts not listed.

Apply clean engine oil or grease to cables and movable parts not specified.

This will avoid abnormal noise and rise the durability of the motorcycle.



# 1. GENERAL INFORMATION

## CABLE & HARNESS ROUTING

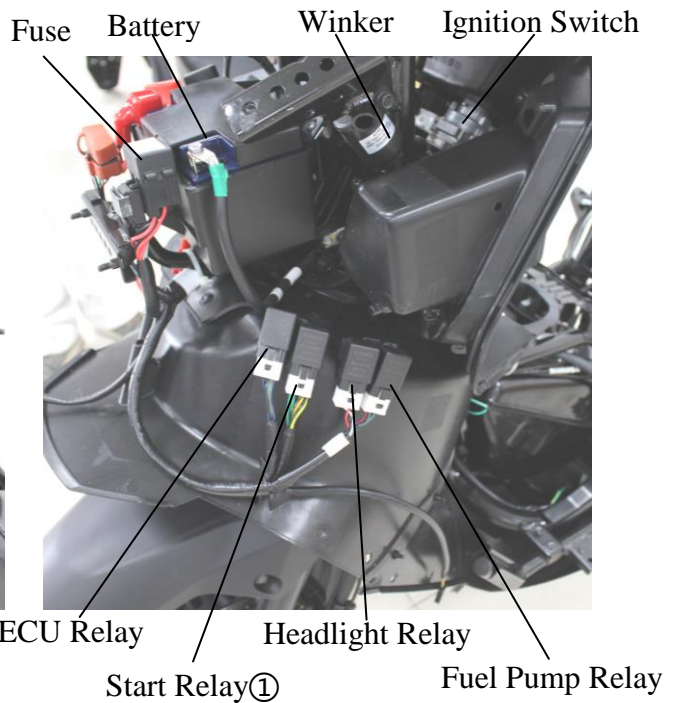
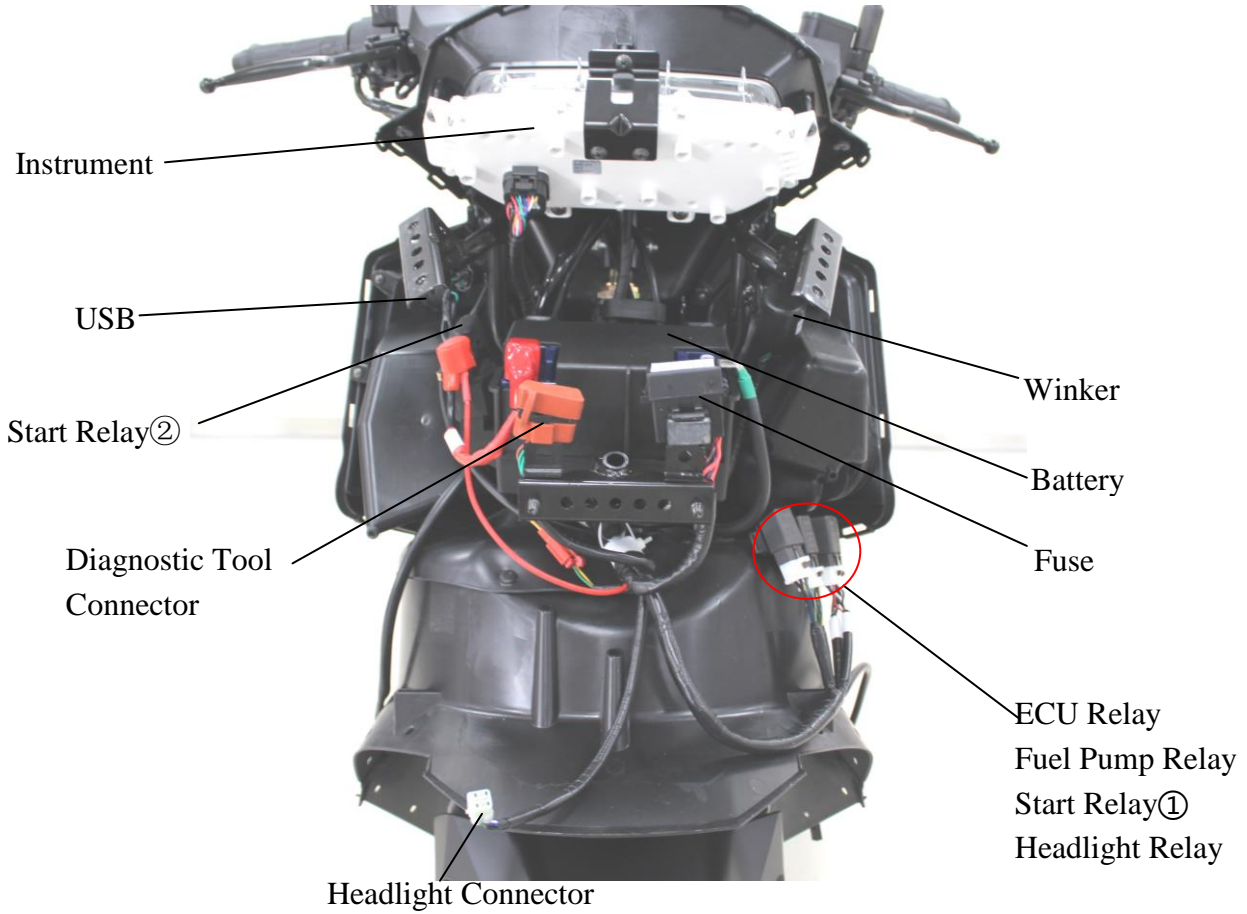



# 1. GENERAL INFORMATION

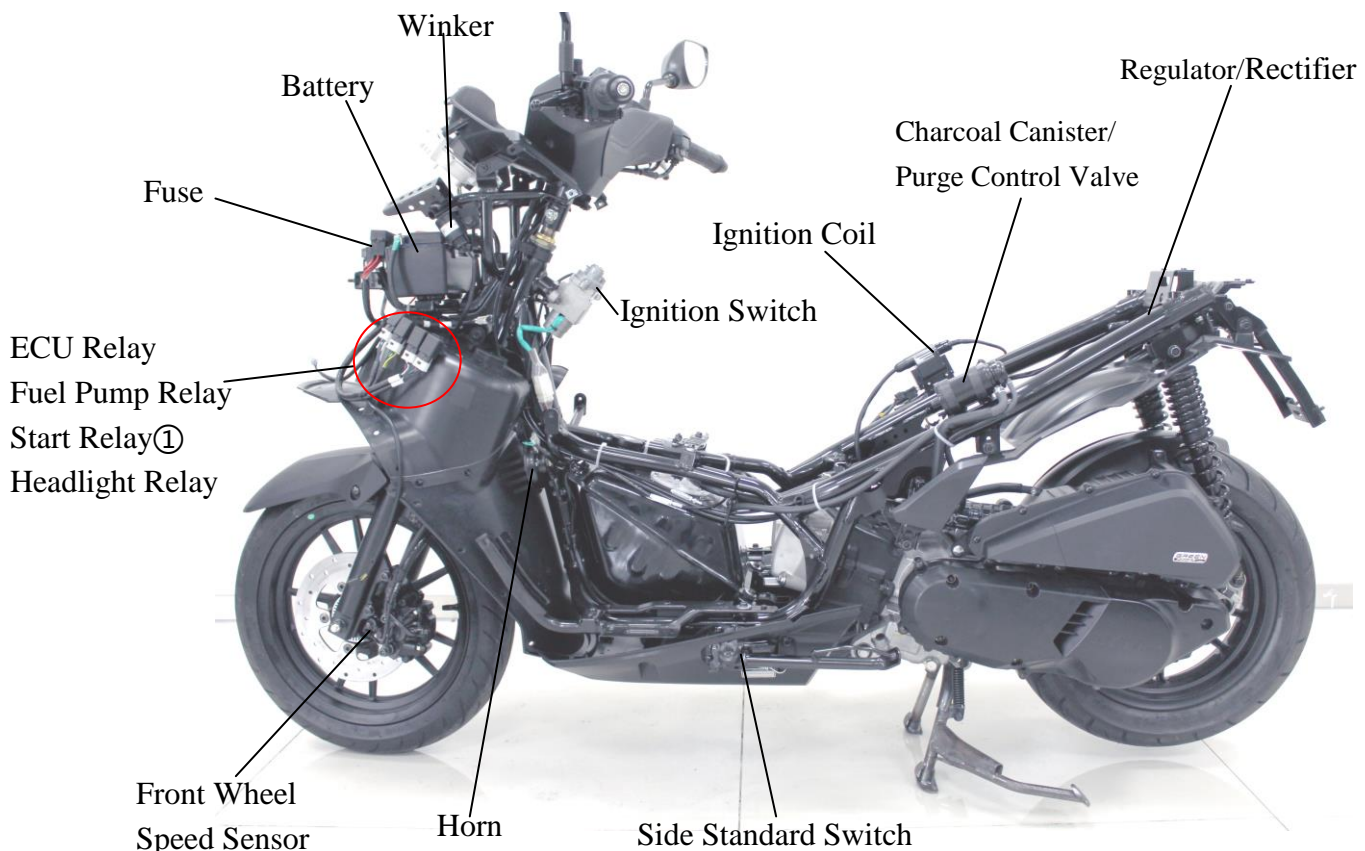
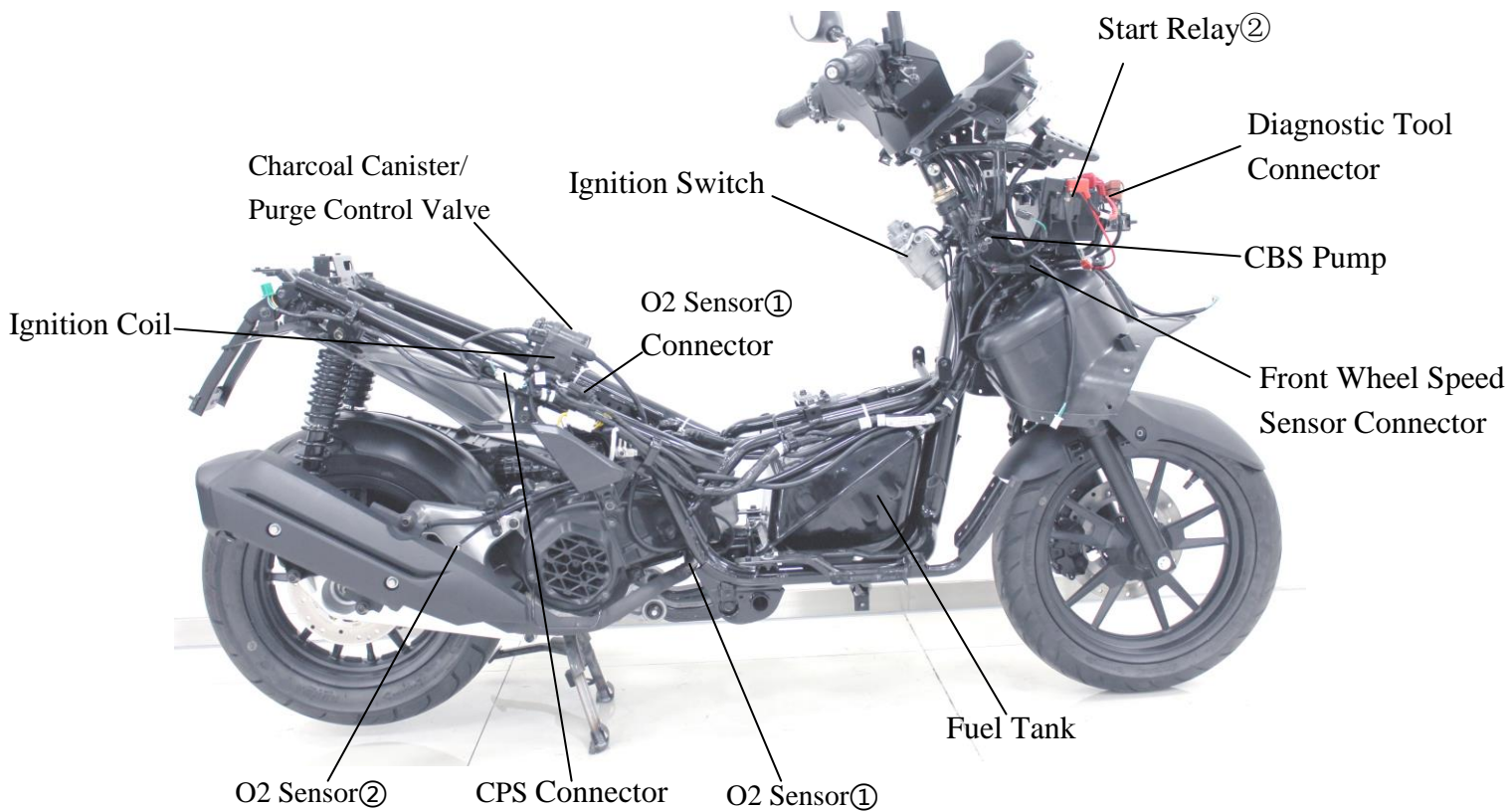

# 1. GENERAL INFORMATION

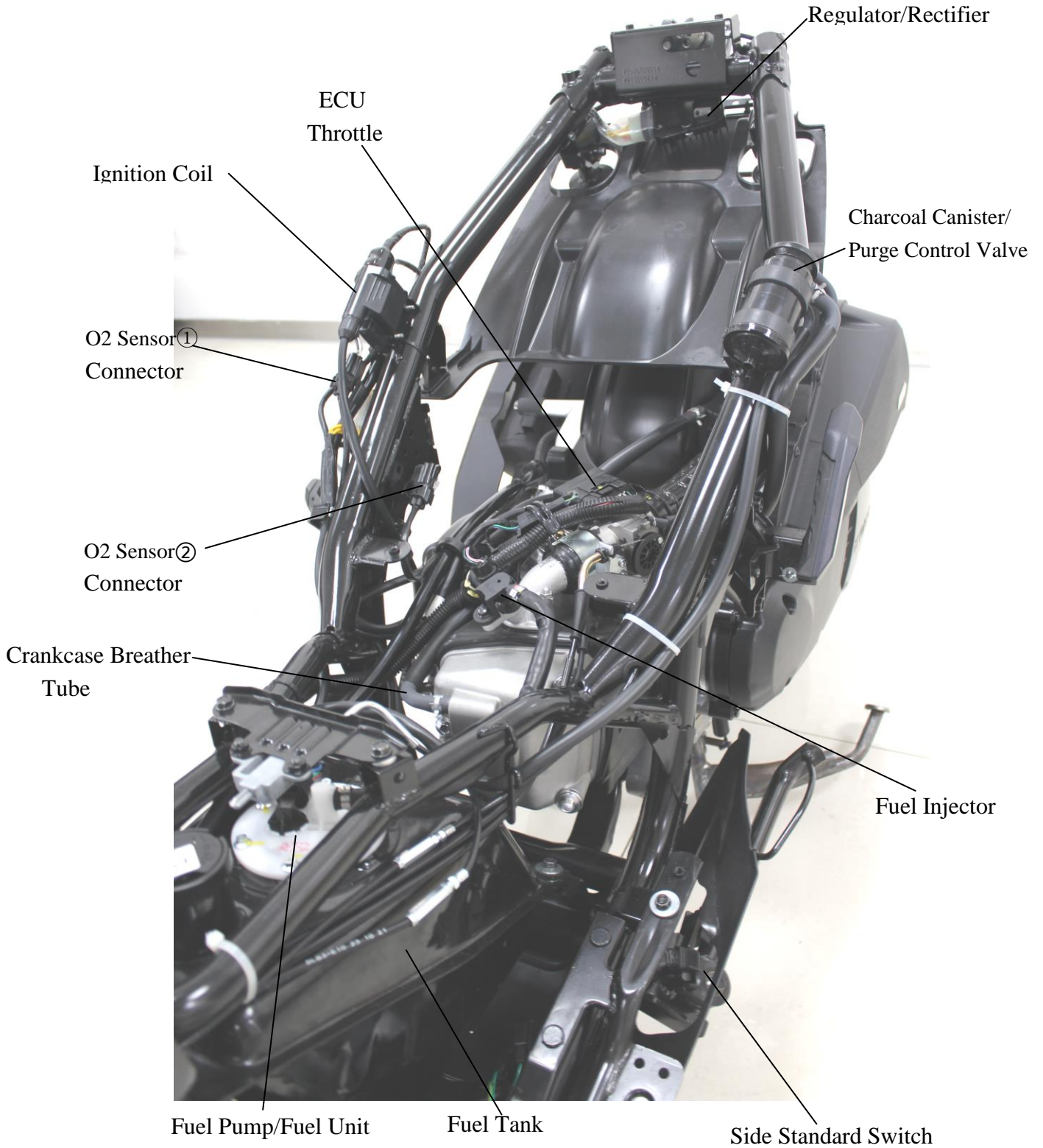



# 1. GENERAL INFORMATION

---

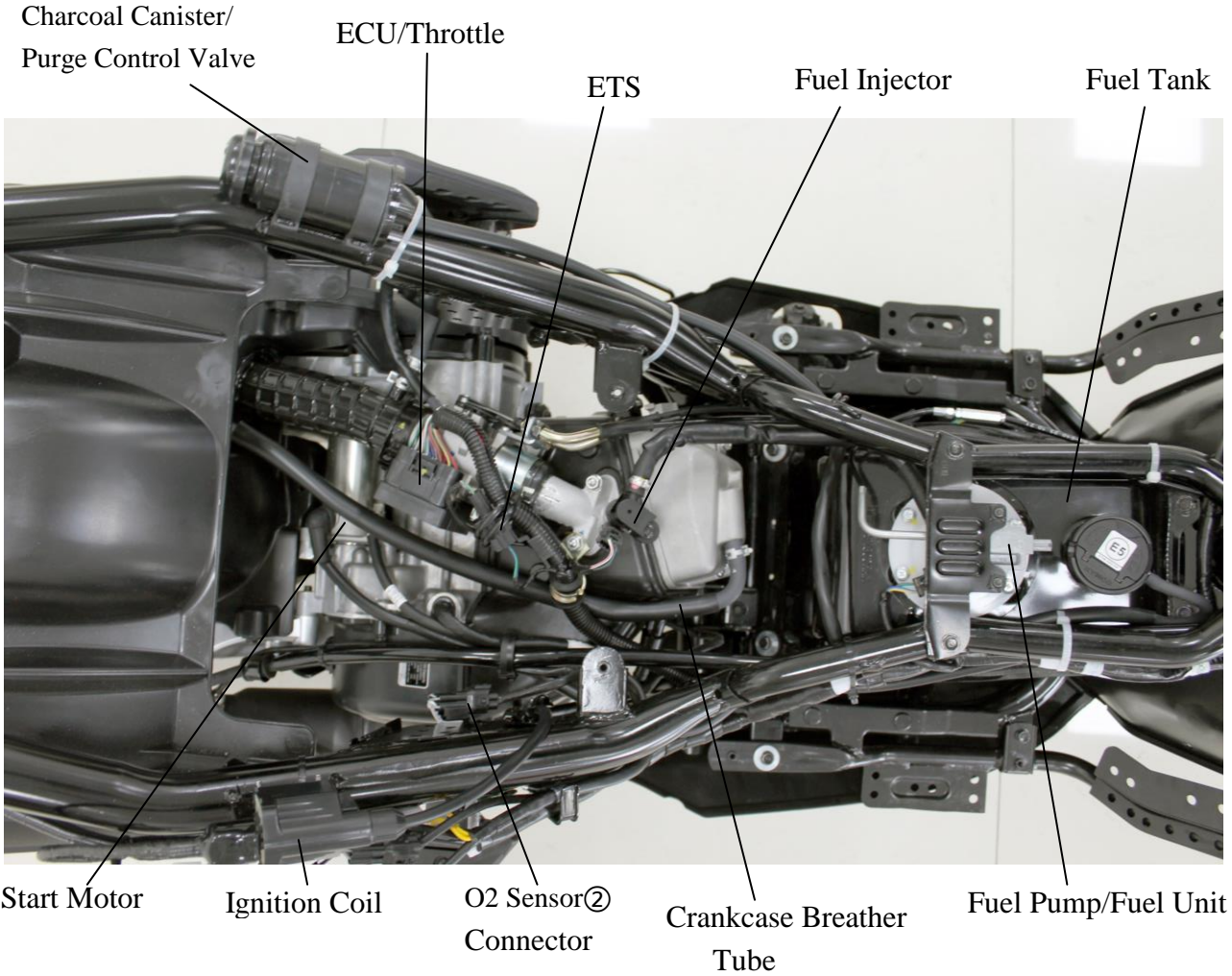

# 1. GENERAL INFORMATION

---

## Troubleshooting

### Vehicle can not be started

#### Preliminary 6 Step Inspection

1. Is the battery fully charged (12 V or higher). See the Battery topic for more information.
2. Key-On and listen for any action with Fuel Pump / Fuel Pump Relay (It will turn off automatically in 5-10 seconds)
3. Key-On to check for any failure lamp light up on dashboard. See the Self-Diagnosis topic for more information.
4. Is the Idle screw of Throttle Valve being changed or loose?
5. Has the vehicle under regular service? Is the gas station a good one?
6. Is the spark plug the correct model of specified by the vehicle builder?

# 1 GENERAL INFORMATION

---

## General Troubleshooting

### ENGINE WILL NOT START OR IS HARD TO START

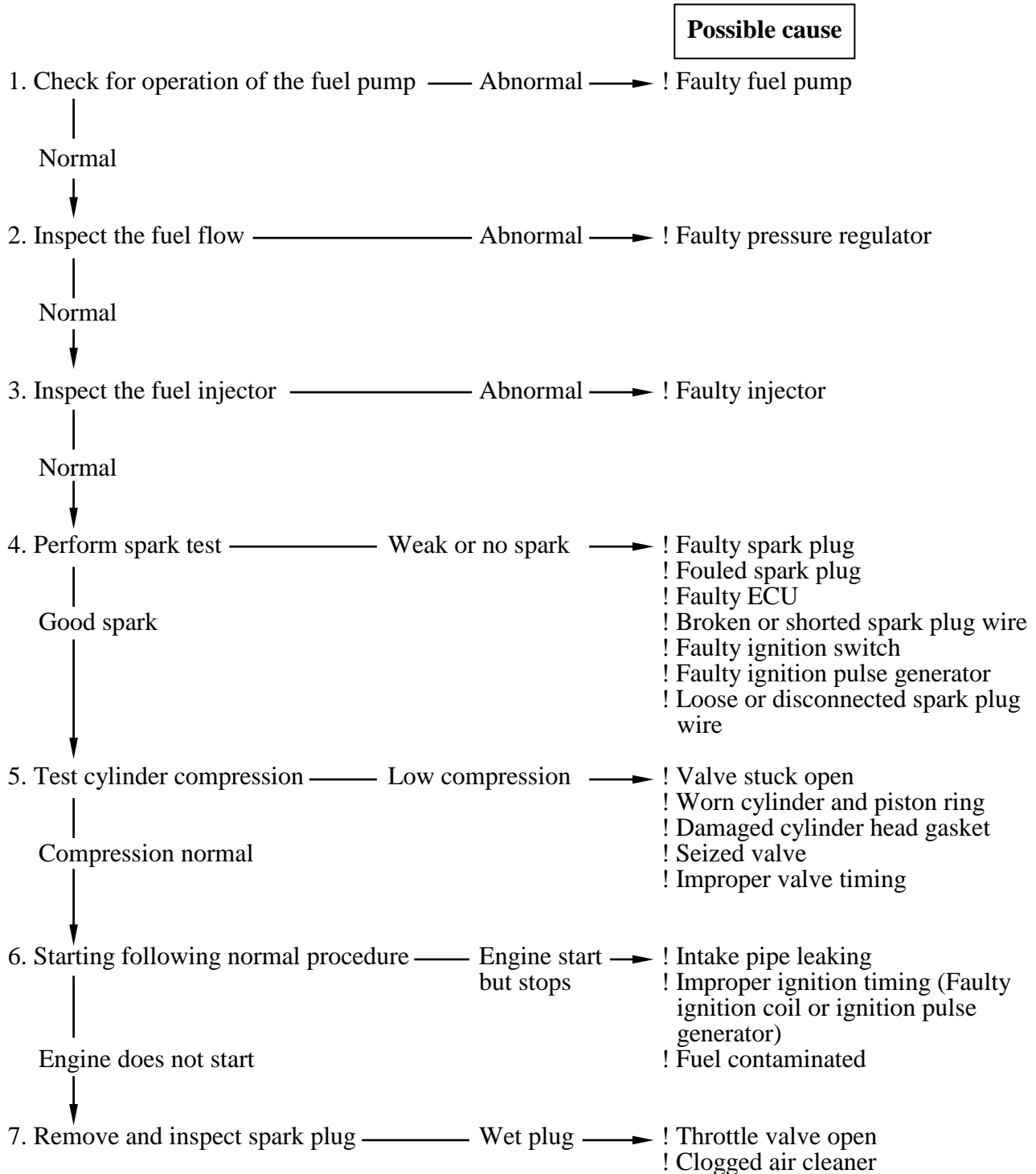

# 1. GENERAL INFORMATION

## ENGINE LACKS POWER

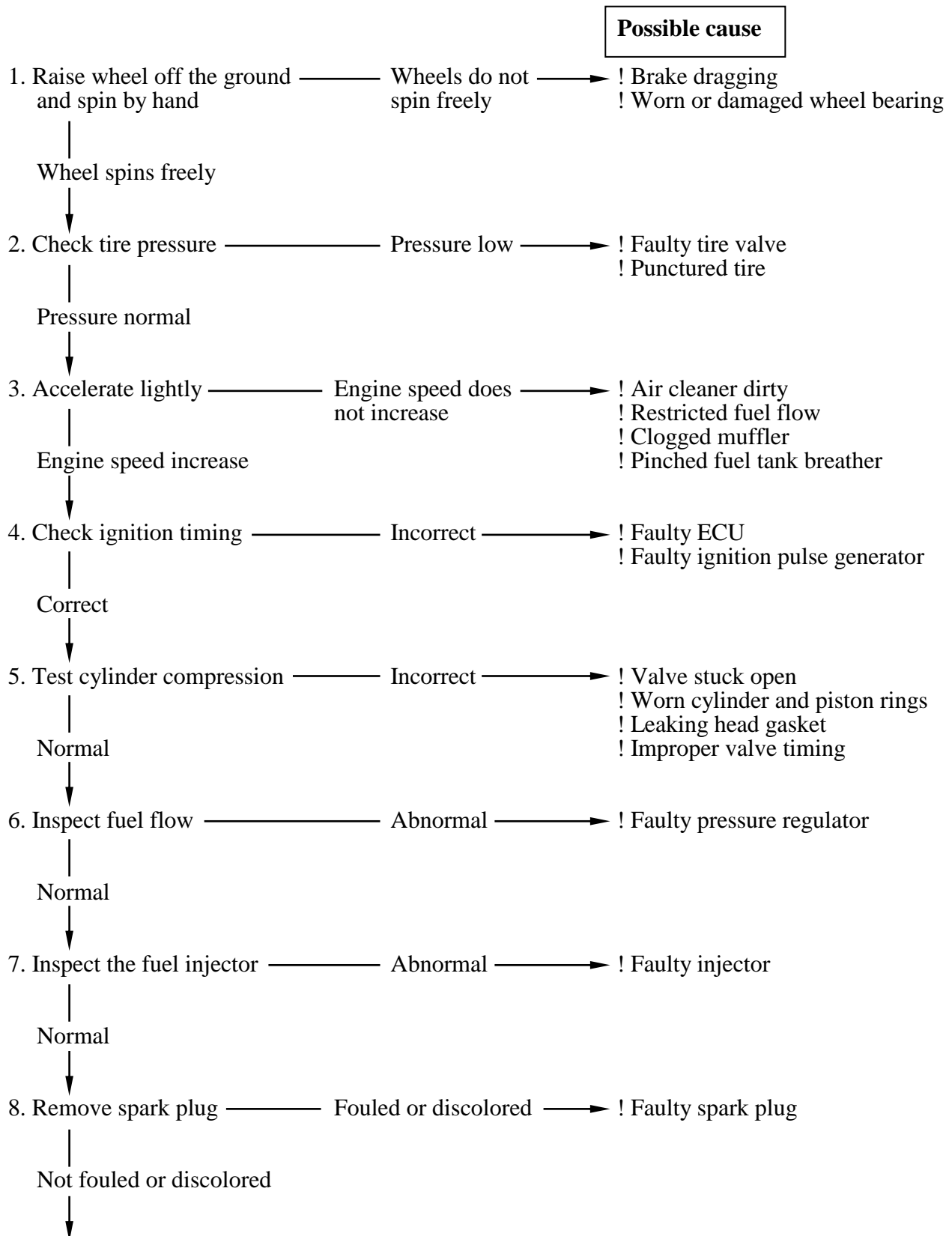

# 1 GENERAL INFORMATION

---

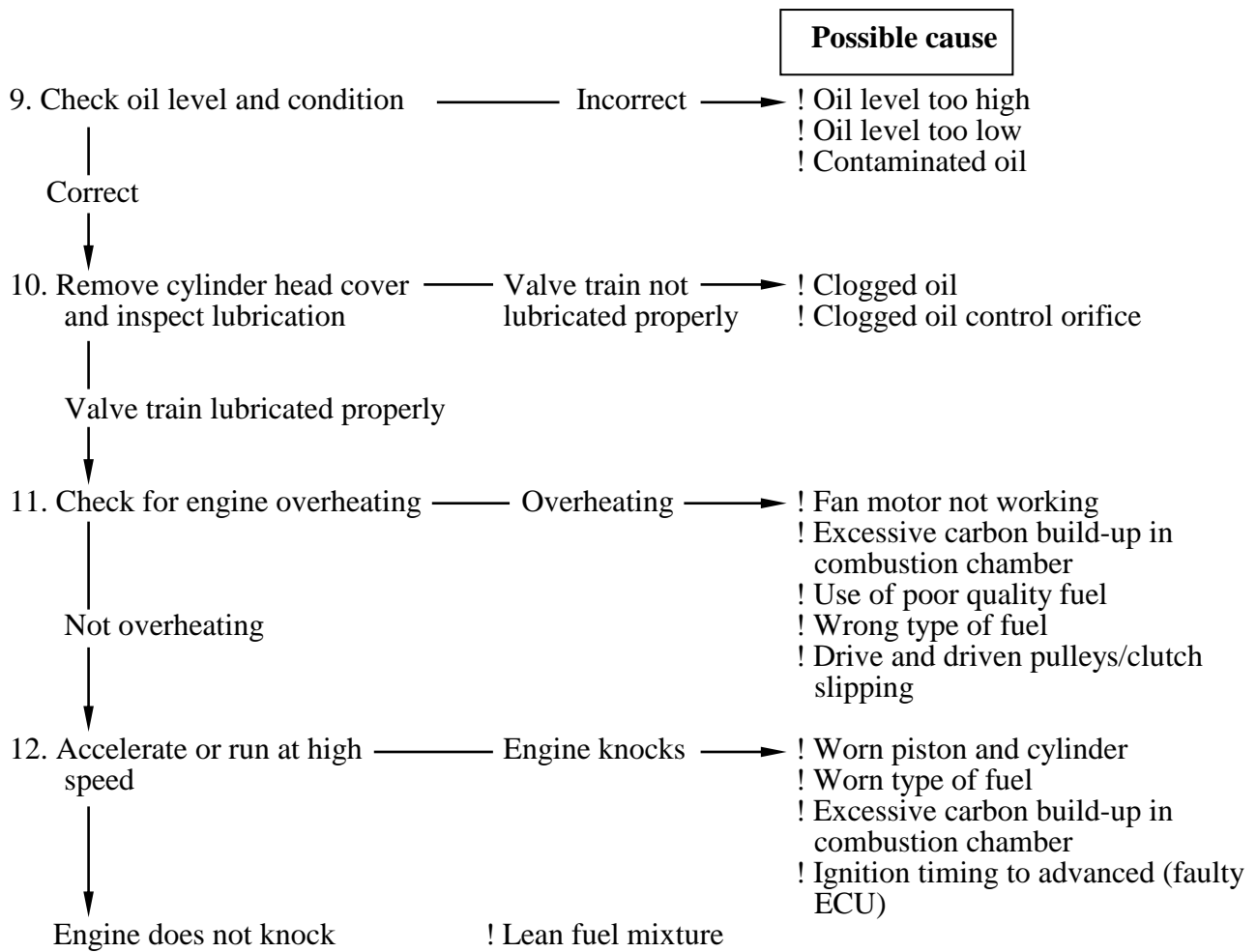

# 1. GENERAL INFORMATION

---

## POOR PERFORMANCE AT LOW AND IDLE SPEED

<b>Possible cause</b>
-----------------------

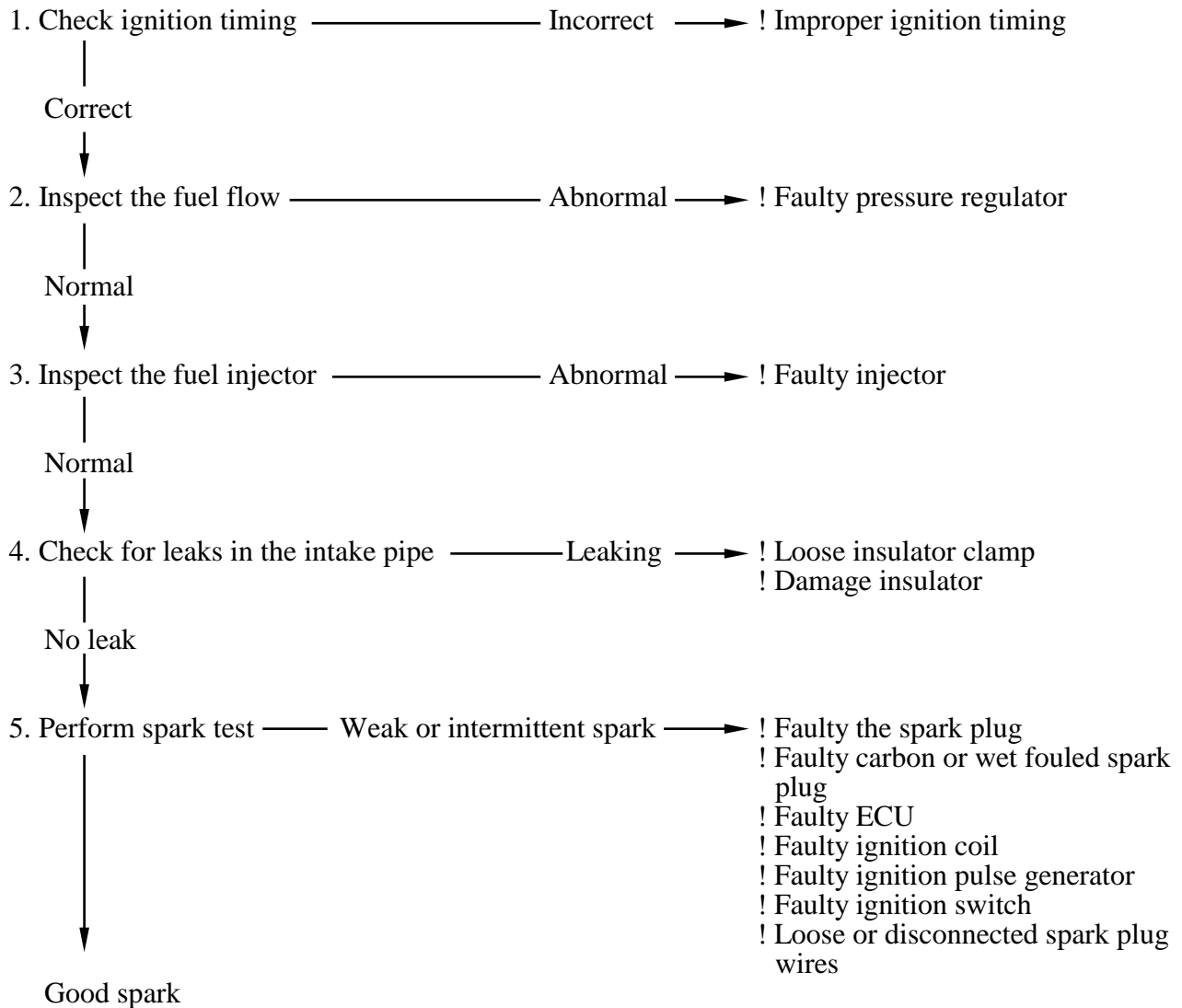

# 1 GENERAL INFORMATION

---

## POOR PERFORMANCE AT HIGH SPEED

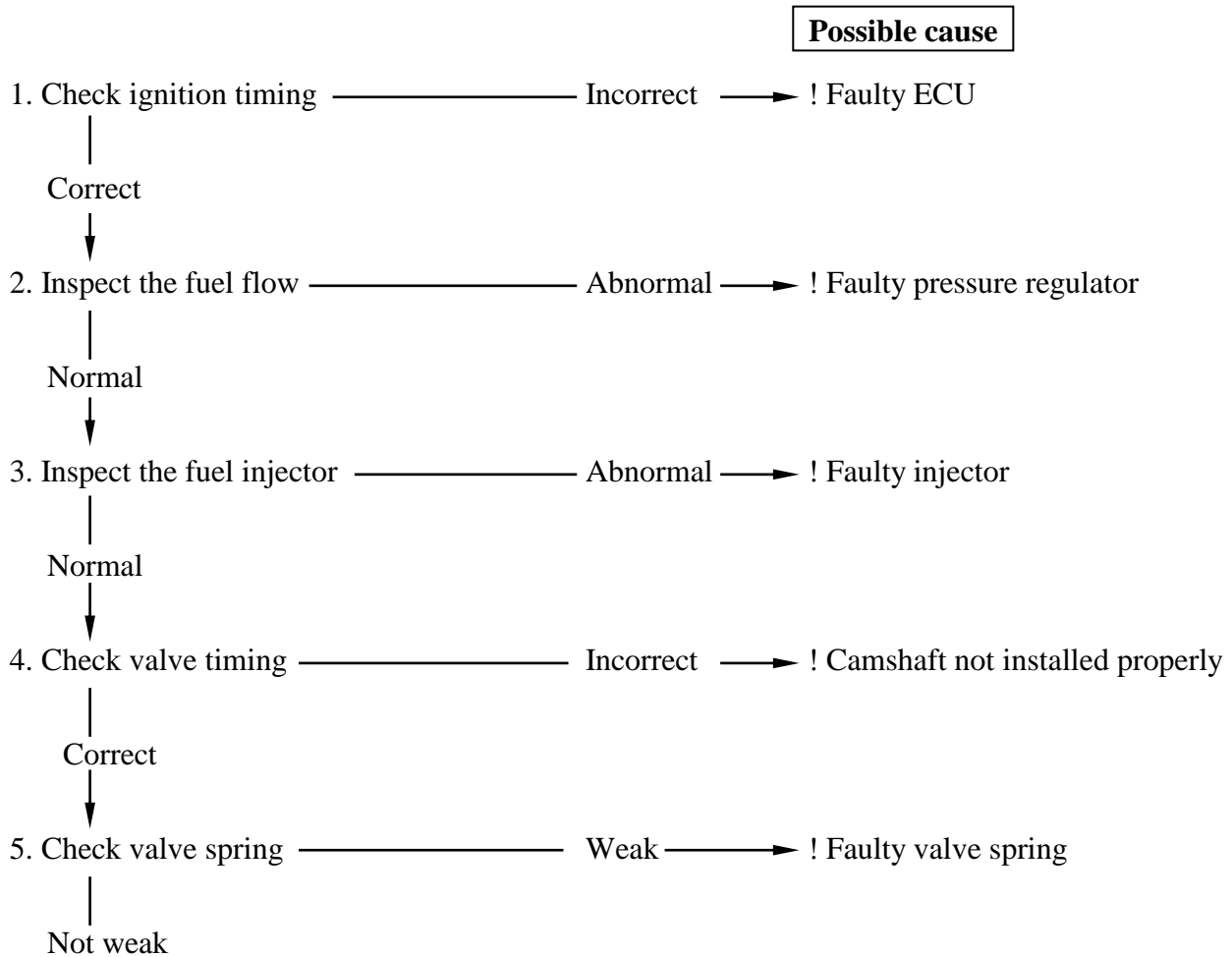

## POOR HANDLING

	<b>Possible cause</b>
1. If steering is heavy —————→	! Steering stem adjusting nut too tight ! Damaged steering head bearings
2. If either wheel is wobbling —————→	! Excessive wheel bearing play ! Bent rim ! Improper installed wheel hub ! Swing arm pivot bearing excessively worn ! Bent frame
3. If the motorcycle pulled to one side —————→	! Faulty the shock absorber ! Front and rear wheel not aligned ! Bent fork ! Bent swing arm ! Bent axle

---

## **2. EXHAUST MUFFLER/FRAME COVERS**

---

---



---

---

### **EXHAUST MUFFLER/FRAME COVERS**

---

SERVICE INFORMATION-----	2- 1
TROUBLESHOOTING-----	2- 1
FASTENER REMOVAL AND REINSTALLATION-----	2- 2
FRAME COVERS REMOVAL/INSTALLATION-----	2- 3
EXHAUST MUFFLER -----	2-12



## **2. EXHAUST MUFFLER/FRAME COVERS**

---

### **SERVICE INFORMATION**

#### **GENERAL INSTRUCTIONS**

- When removing frame covers, use care not to pull them by force because the cover joint claws may be damaged.
- Make sure to route cables and harnesses according to the Cable & Harness Routing.

#### **TORQUE VALUES**

Exhaust muffler pipe nuts	1.8~2.2 kgf-m
Exhaust muffler brake /RR Fork	3.2~3.8 kgf-m
RR fork/Engine case	3.0~4.0 kgf-m

### **TROUBLESHOOTING**

#### **Noisy exhaust muffler**

- Damaged exhaust muffler
- Exhaust muffler joint air leaks

#### **Lack of power**

- Caved exhaust muffler
- Clogged exhaust muffler
- Exhaust muffler air leaks

## 2. EXHAUST MUFFLER/FRAME COVERS

### FASTENER REMOVAL AND REINSTALLATION

#### REMOVAL

Depress the head of fastener center piece ←.  
Pull out the fastener.

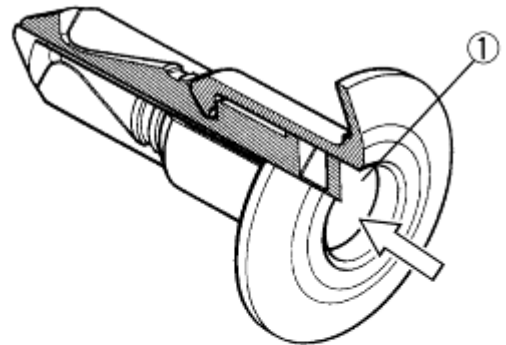

#### INSTALLATION

Let the center piece stick out toward the head so that the pawls ↑ close.  
Insert the fastener into the installation hole.

\* To prevent the pawl ↑ from damage, insert the fastener all the way into the installation hole

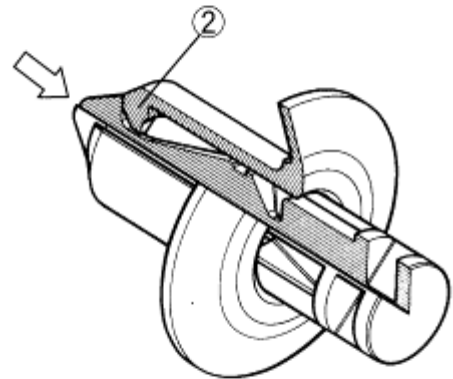

Push in the head of center piece until it becomes flush with the fastener outside face.

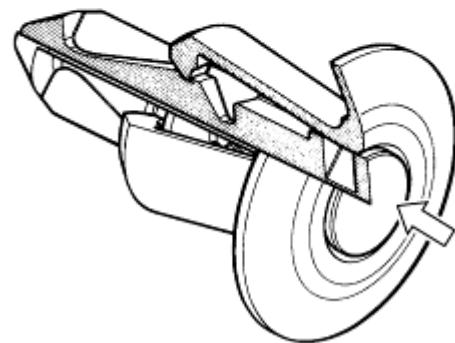

## 2. EXHAUST MUFFLER/FRAME COVERS

---

### FRAME COVERS REMOVAL/ INSTALLATION

#### MET-IN BOX REMOVAL

Unlock the seat with the ignition key.  
Open the seat.  
Remove the 4 bolts attaching the met-in box.  
Remove the met-in box .

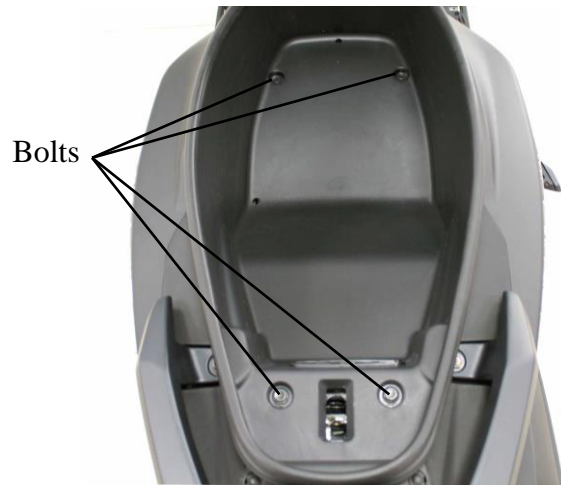

Remove the Center Cover.

Installation is in the reverse order of removal.

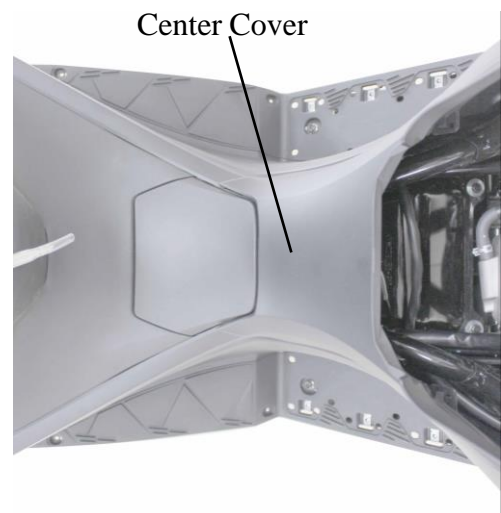

#### REAR CARRIER REMOVAL

Remove the three bolts and then remove the rear carrier.

Installation is in the reverse order of removal.



## 2. EXHAUST MUFFLER/FRAME COVERS

### BODY COVER

Remove two fasteners and then remove the rear center cover

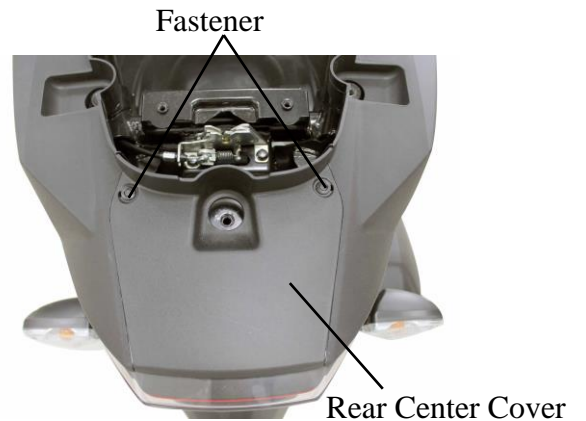

Remove four fasteners and two nuts.

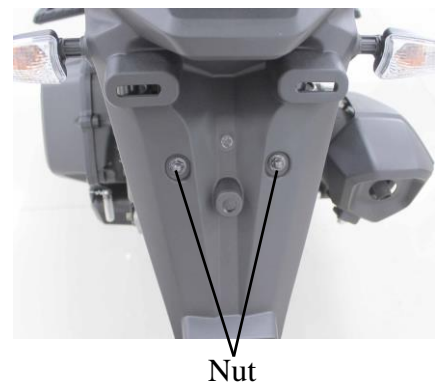
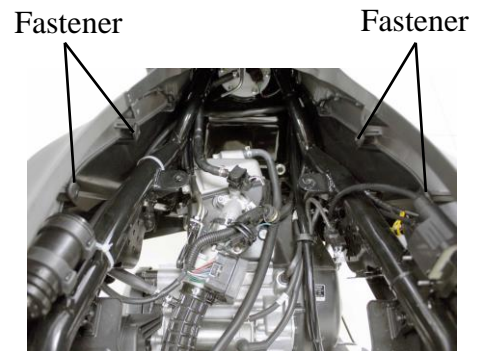

Remove the six fasteners attaching to the right and left the body .

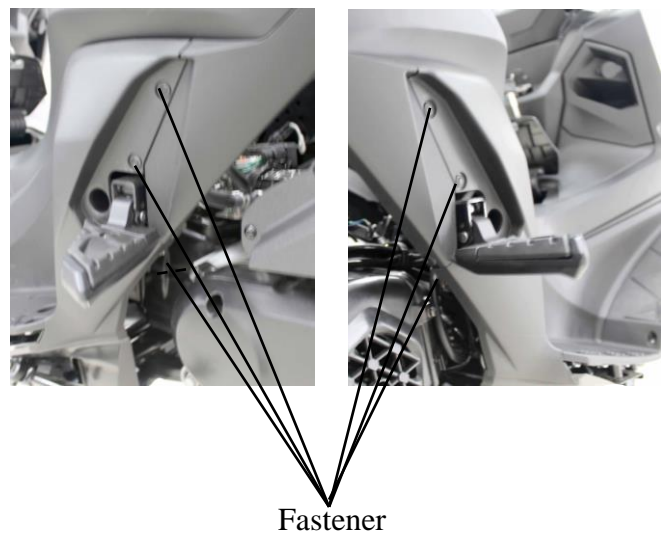

## 2. EXHAUST MUFFLER/FRAME COVERS

Disconnect the taillight connector, then remove the body cover.

Installation is in the reverse order of removal.

taillight connector

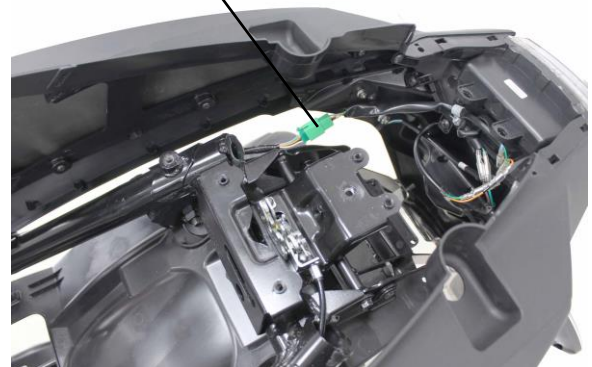

### UPPER/LOWER HANDLEBAR COVER

Remove the two screws .  
Remove upper handlebar cover.

Screw(upper handlebar cover)

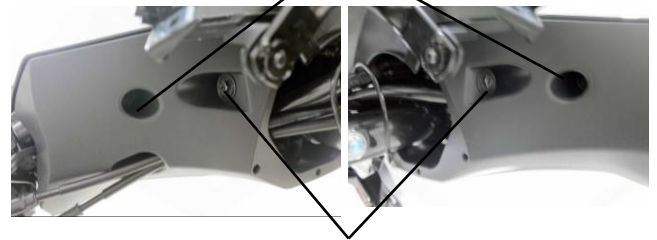

Bolt(lower handlebar cover)

Remove the two bolts and the two screws.



Screw

Disconnect the throttle cable refer to the “**THROTTLE BODY /TPS**” section, then pull the throttle cable out from the lower cover.  
Remove the lower cover.

Installation is in the reverse order of removal.



the throttle cable

## 2. EXHAUST MUFFLER/FRAME COVERS

### WINDSHIELD

Remove the four bolts.  
Remove the windshield.



Bolt

### FRONT CENTER COVER

Remove the windshield  
Remove the four bolts and the windshield  
bracket.  
Remove the two screws.  
Remove the front center cover.

Screw



Installation is in the reverse order of removal

### RIGHT/LEFT FOOT SKIRT

Remove the screws attaching to the right or  
left skirt.

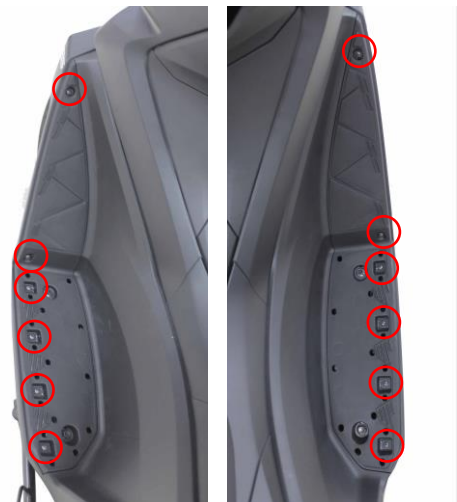



## 2. EXHAUST MUFFLER/FRAME COVERS

Remove the fasteners attaching under cover and the right or left skirt.

Disconnect the right/left turn signal light connectors.

Remove the right or left skirt.

\* During removal, do not pull the joint claws forcedly to avoid damage.

Installation is in the reverse order of removal.

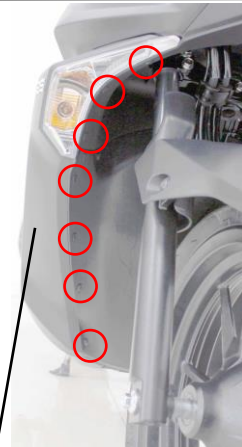

Right Foot skirt

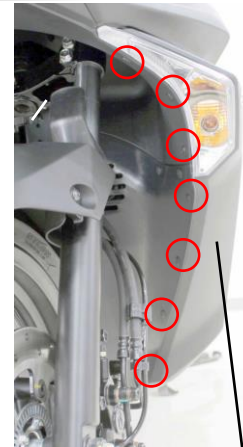

Left Foot skirt



Turn signal light connector

Fastener

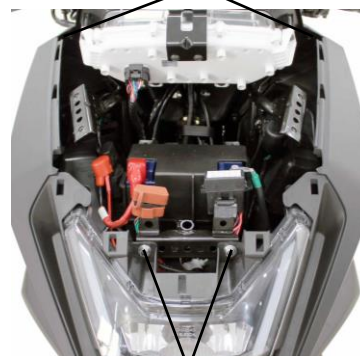

Nut

### FRONT COVER

Remove the body cover

Remove the windshield.

Remove the front center cover.

Remove the right and left skirt.

Remove the right and left floorboard.

Remove the two Fasteners and the two nuts.

Remove the four fasteners from the inner cover.

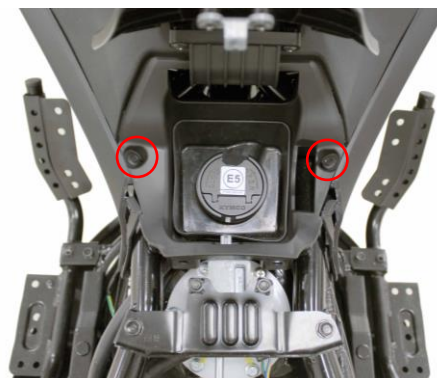

## 2. EXHAUST MUFFLER/FRAME COVERS

Disconnect the headlight light connector.



headlight light connector

Remove the front cover

Installation is in the reverse order of removal.



### FRONT FENDER

Remove the four bolts attaching to the front fender.

Installation is in the reverse order of removal.

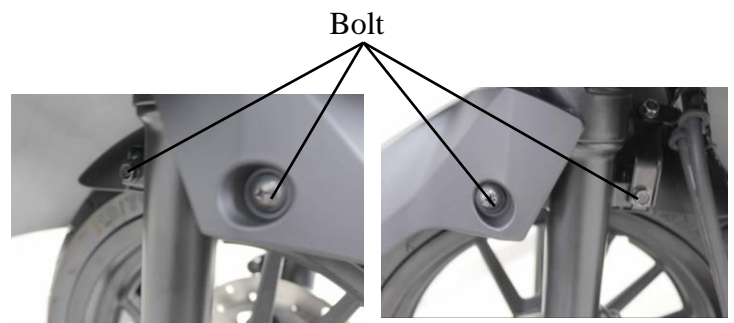

### FLOORBOARD

Remove the body cover.  
Remove the right and left skirt.  
Remove the right and left Passenger foot pegs.  
Remove the six bolts .  
Remove the right and left floorboard.

Installation is in the reverse order of removal.

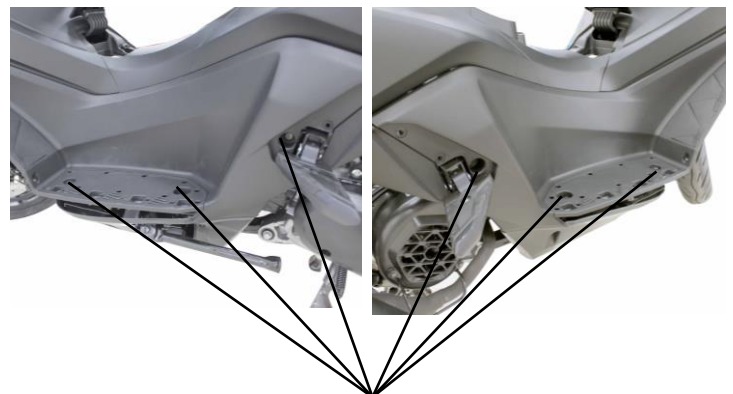

Bolt



## 2. EXHAUST MUFFLER/FRAME COVERS

### METER PANEL

Remove the front cover.  
 Remove the inner cover.  
 Remove the four bolts.

Disconnect the meter connector.  
 Remove meter panel.

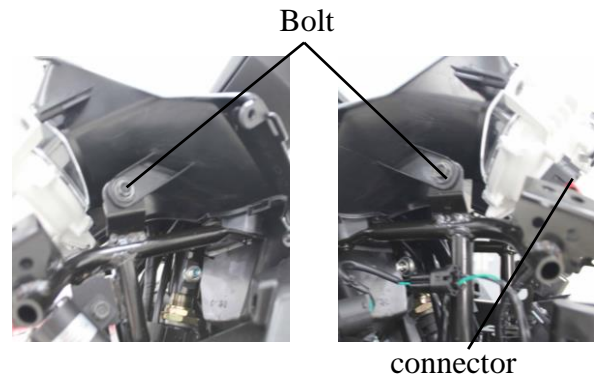

Bolt

connector

Installation is in the reverse order of removal.



Bolt

### INNER COVER

Remove the front cover.  
 Remove the one screws  
 Remove the ignition key garnish.

\* During removal, do not pull the joint claws forcedly to avoid damage.



Screw

Remove the two bolts attaching to the inner cover.



Bolt

Remove the fuel filler cap .

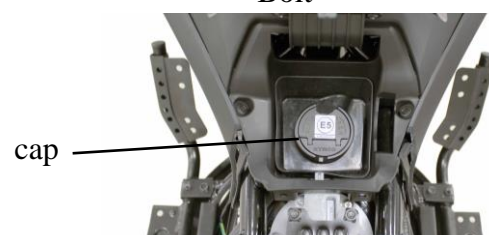

cap

## 2. EXHAUST MUFFLER/FRAME COVERS

Disconnect the connector of USB.



Remove the inner cover.

Installation is in the reverse order of removal.

### FRONT INNER FENDER

Remove the six fasteners, connect front inner fender and the top inner fender



front inner fender

Remove front inner fender

### TOP INNER FENDER

Disconnect the connector of relays

Remove the eleven fasteners.

Remove the top inner fender

Relay

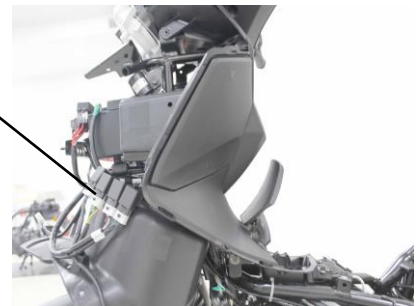

## 2. EXHAUST MUFFLER/FRAME COVERS

---

### UNDER COVER

Remove four bolts and two fasteners attaching to under cover.

Remove the under cover.



Fastener

Bolt

### REAR FENDER

Remove the one screw.

Remove the two bolts.

Remove the rear fender rear.

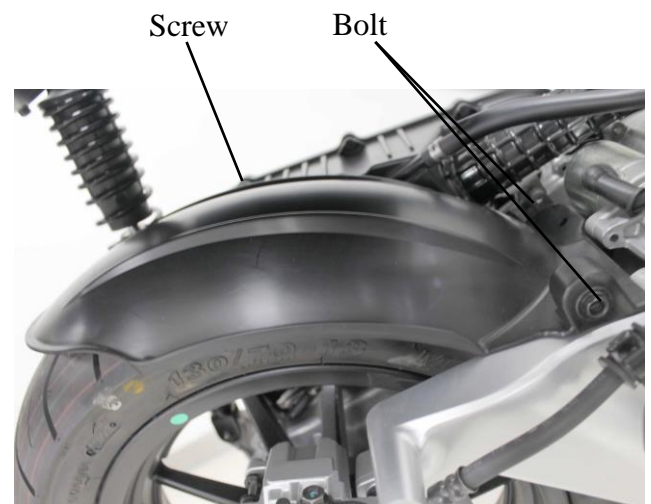

Screw

Bolt

### FENDER, REAR INNER

Remove the four bolts.

Remove the rear shock absorber upper mount bolt.

Remove the fender rear inner.



Bolt

## 2. EXHAUST MUFFLER/FRAME COVERS

---

### EXHAUST MUFFLER

#### REMOVAL

Disconnect the two connectors with O2 heater/O2 sensor.

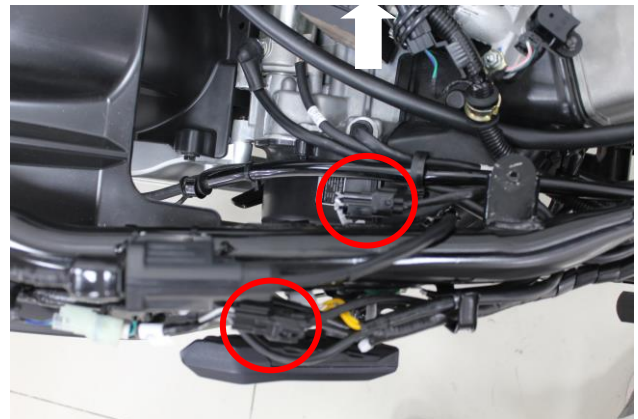

Remove the two exhaust pipe joint nuts



Nut

Remove three muffler mount bolts and muffler and gasket.



Bolt

## 2. EXHAUST MUFFLER/FRAME COVERS

---

### INSTALLATION

Replace the gasket with a new one.  
Install the exhaust muffler and three mounting bolts.

Install and tighten the two exhaust pipe joint nuts to the specified torque

**Torque:** 20 N•m (2 kgf•m,)

Tighten the three mounting bolts

**Torque:** 35 N•m (3.5 kgf•m,)



Gasket



### 3. INSPECTION/ADJUSTMENT

---

---

---



---

### INSPECTION/ADJUSTMENT

---

SERVICE INFORMATION-----	3-1
MAINTENANCE SCHEDULE-----	3-2
FUEL LINE-----	3-3
THROTTLE OPERATION-----	3-3
ENGINE OIL-----	3-4
TRANSMISSION OIL-----	3-4
AIR CLEANER-----	3-5
SPARK PLUG-----	3-5
VALVE CLEARANCE-----	3-6
CYLINDER COMPRESSION-----	3-7
DRIVE BELT-----	3-7
CLUTCH SHOE WEAR-----	3-7
HEADLIGHT AIM-----	3-8
BRAKE FLUID-----	3-8
BRAKE PAD WEAR-----	3-8
CBS-----	3-9

### 3. INSPECTION/ADJUSTMENT

---

#### SERVICE INFORMATION

##### GENERAL

 <b>WARNING</b>
--

- Before running the engine, make sure that the working area is well-ventilated. Never run the engine in a closed area. The exhaust contains poisonous carbon monoxide gas which may cause death to people.
- Gasoline is extremely flammable and is explosive under some conditions. The working area must be well-ventilated and do not smoke or allow flames or sparks near the working area or fuel storage area.

#### SPECIFICATIONS

Throttle grip free play : 2 ~ 6mm

Spark plug : NGK : LR7D

Spark plug gap : 0.6 ~ 0.7 mm

Valve clearance : IN: 0.1mm EX: 0.1mm

Idle speed : 1600 ± 100 rpm

##### Engine oil capacity:

At disassembly : 0.9 Liter

At change : 0.8 Liter

Ignition timing : ECU

Coolant type : air-cooled

##### Gear oil capacity :

At disassembly : 0.13 Liter

At change : 0.11 Liter

##### TIRE

	1Rider	2Riders
Front	1.75 kg/cm <sup>2</sup>	1.75 kg/cm <sup>2</sup>
Rear	2.00 kg/cm <sup>2</sup>	2.25 kg/cm <sup>2</sup>

##### TIRE SPECIFICATION:

Front : 110/70-14

Rear : 130/70-13

##### TORQUE VALUES

Front axle nut : 65 N-m

Rear axle nut : 120 N-m

### 3. INSPECTION/ADJUSTMENT

#### MAINTENANCE SCHEDULE

In order to have a safe riding, maintain good performance, prolong the scooter service life and reduce pollution, make sure to perform the periodic inspection and maintenance.

**I: Inspect and clean, lubricate, refill, repair or replace if necessary.**

**A: Adjust C: Clean R: Replace T: Tighten D: Inspect with Diagnosis Instrument**

**M : Mintenance**

FREQUENCY	ITEM	WHICHEVER COMES FIRST	ODOMETER READING (NOTE1)							REFER TO PAGE	
		→	X 1000 km	0.3	1	3	5	7	9		11
		↓	X 1000 mi	0.2	0.6	1.8	3	4.2	5.4		6.6
		MONTH		3	6	9	12	15	18		
*	AIR CLEANER			I	R	I	R	I	R		
	SPARK PLUG					I		R	I		
*	THROTTLE OPERATION			I	I	I	I	I	I		
*	VALVE CLEARANCE			A			A				
*	FUEL LINE						I				
	CRANKCASE BREATHER			C	C	C	C	C	C		
	ENGINE OIL		R	R	R	R	R	R	R		
*	ENGINE OIL SCREEN		C	C	C	R	C	C	R		
*	ENGINE IDLE SPEED				I		I		I		
*	TRANSMISSION OIL		R		R		R		R		
*	DRIVE BELT		Inspect every 5000km,replace every 20000km								

*	CLUTCH SHOE WEAR				I		I		I	
	BRAKE FLUID		Replace at every 10000km or every year							
	BRAKE PAD WEAR			I	I	I	I	I	I	
	BRAKE SYSTEM			I	I	I	I	I	I	
*	BRAKE LIGHT SWITCH			I	I	I	I	I	I	
*	STEERING BEARINGS			I	I	I	I	I	I	
*	HEADLIGHT AIM			I	I	I	I	I	I	
*	NUTS,BOLTS,FASTENERS			T	T	T	T	T	T	
*	WHEEL/TIRES			I	I	I	I	I	I	
*	CVT FILTER					C			C	
*	INJECTOR			D	D	C	D	D	C	

The above items are applicable to different models. Perform suitable items for each model. When exceeding the listed mileages, perform maintenance according to the listed intervals.

The air cleaner requires more frequent cleaning or replacing when ridden in unusually dusty areas.



### 3. INSPECTION/ADJUSTMENT

#### FUEL LINE

Check the fuel lines and replace any parts, which show signs of deterioration, damage or leakage.

Check for dirty or clogged fuel injector and replace with a new one if it is clogged.

\* Do not smoke or allow flames or sparks in your working area.

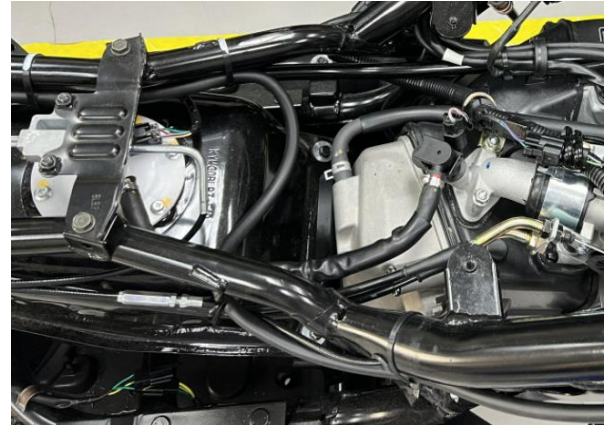

#### THROTTLE OPERATION

Check the throttle grip for smooth movement. Measure the throttle grip free play.

**Free Play:** 2~6 mm

Major adjustment of the throttle grip free play is made with the adjusting nut at the intake manifold side. Adjust by loosening the lock nut and turning the adjusting nut.

Minor adjustment is made with the adjusting nut at the throttle grip side. Slide the rubber cover(1) out and adjust by loosening the lock nut(3) and turning the adjusting nut(2).



Lock Nut

Adjusting Nut



(1)

(2)

(3)

### 3. INSPECTION/ADJUSTMENT

#### ENGINE OIL

##### Engine oil recommendation

Use a premium quality 4-stroke motor oil to ensure longer service life of your scooter. Use only oils which are rated, SL under the API service classification. The recommended viscosity is SAE 15W-40.

If SAE 15W-40 motor oil is not available, select an alternative according to the right chart.

##### Engine oil capacity:

At disassembly: 0.9 L

At change: 0.8 L

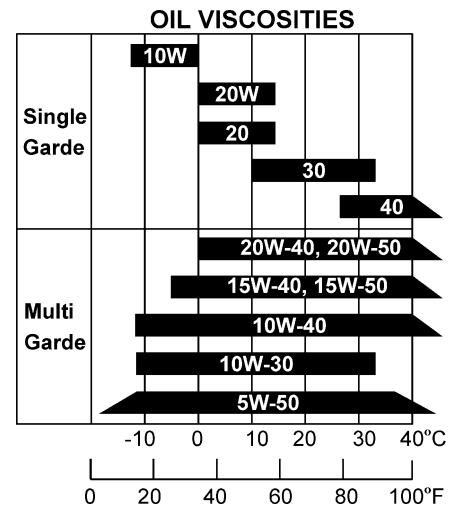

##### Oil strainer screen clean

Clean the oil strainer screen. Check that the oil strainer screen, sealing rubber and drain plug O-ring are in good condition.



Oil strainer screen



Oil drain bolt

#### TRANSMISSION OIL

##### Oil change

Fill the transmission case with recommended oil. Recommended transmission oil: SAE 90  
Oil capacity (at draining): 0.12L



fluid drain bolt

filler bolt

### 3. INSPECTION/ADJUSTMENT

#### AIR CLEANER

##### Air cleaner element replacement

Remove the eight screws.

Remove the air cleaner cover.

Remove the air cleaner element and replacement new one.



- \* 
  - The air cleaner element has a viscous type paper element. Do not clean it with compressed air.
  - Be sure to install the air cleaner element and cover securely.



#### SPARK PLUG

Remove the spark plug cap and spark plug.  
Check the spark plug for wear and fouling deposits.

Clean any fouling deposits with a spark plug cleaner or a wire brush.

Specified Spark Plug: LR7D (NGK)

Measure the spark plug gap.

Spark Plug Gap: 0.6 ~ 0.7mm

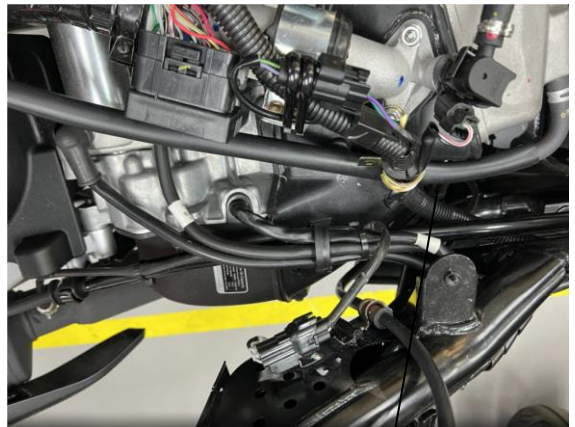

spark plug cap

- \* 

When installing, first screw in the spark plug by hand and then tighten it with a spark plug wrench.

Torque: 0.9 kgf-m

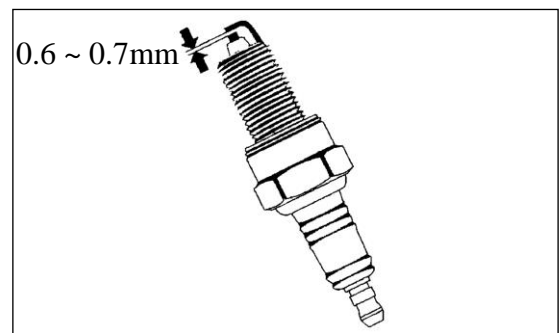



### 3. INSPECTION/ADJUSTMENT

#### VALVE CLEARANCE

- \* • Inspect and adjust valve clearance while the engine is cold (below 35°C).

Remove the met-in box. (⇒ 2-3)

Remove the Center Cover. (⇒ 2-3)

Remove the three bolts on the cylinder head cover.

Remove the cylinder head cover.



Remove the fan cover.

Turn the A.C. generator flywheel clockwise to the top dead center (TDC) on the compression stroke so that the "T" mark on the flywheel aligns with the index mark on the right crankcase cover.

The punch mark on the camshaft should face Upward. If the punch mark on the camshaft are facing downward, turn the crankshaft clockwise one full turn (360°) and the punch mark are facing upward.



Adjust by loosening the valve adjusting screw lock-nut and turning the adjusting screw until there is a slight drag on the thickness gauge.

**Valve Clearance:** IN: 0.10mm  
EX: 0.10 mm

Apply oil to the valve adjusting screw lock-nut threads and seating surface.

Hold the adjusting screw and tighten the lock nut to the specified torque.

**Torque:** 0.9 kgf-m

#### Special tool:

Valve adjuster A120E00036

After tightening the lock-nut, recheck the valve clearance.

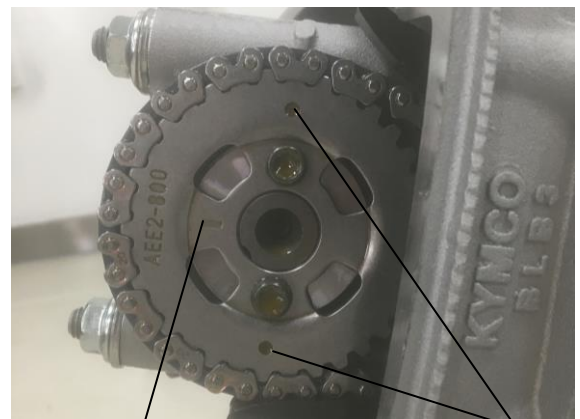

Punch mark

Round Hole



Valve adjuster

### 3. INSPECTION/ADJUSTMENT

#### CYLINDER COMPRESSION

Warm up the engine before compression test.  
 Remove the center cover and spark plug cap.  
 Remove the spark plug .  
 Insert a compression gauge.  
 Open the throttle valve fully and push the starter button to test the compression.

**Compression:**  $15 \pm 2 \text{ kgf/cm}^2$

If the compression is low, check for the following:

- Leaky valves
- Valve clearance too small
- Leaking cylinder head gasket
- Worn pistons
- Worn piston/cylinder

If the compression is high, it indicates that carbon deposits have accumulated on the combustion chamber and the piston head.

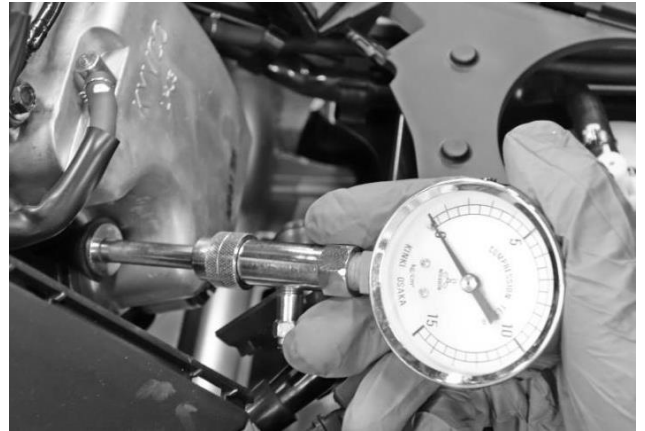

#### DRIVE BELT

Remove the left crankcase cover.  
 Inspect the drive belt for cracks or excessive wear.  
 Replace the drive belt with a new one if necessary and in accordance with the Maintenance Schedule.



drive belt

#### CLUTCH SHOE WEAR

Start the engine and check the clutch operation by increasing the engine speed gradually.  
 If the scooter tends to creep, or the engine stalls, check the clutch shoes for wear and replace if necessary.

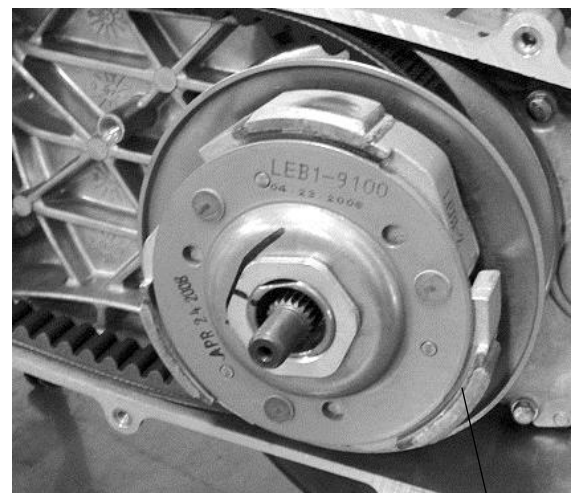

Clutch Shoes

### 3. INSPECTION/ADJUSTMENT

#### HEADLIGHT ADJUSTMENT

Headlight aim can be made by turning the screw in or out as necessary.

Place the scooter on a level surface.  
Adjust the headlight beam adjuster.

A clockwise rotation moves the beam up and counterclockwise rotation moves the beam down.

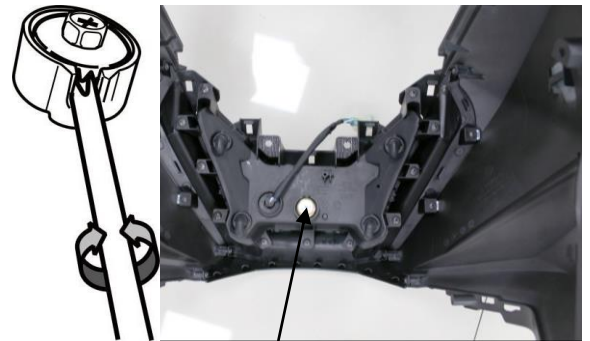

Adjustment Screw

#### BRAKE FLUID

##### Brake fluid level:

With the scooter in an upright position, check the front and rear fluid level. It should be above the lower level mark. If the level is at or below the lower level mark "L", check the brake pads for wear.

Worn pads should be replaced. If the pads are not worn, have your brake system inspected for leaks.

The recommended brake fluid is **DOT 4** brake fluid from a sealed container, or an equivalent.



Front brake

#### BRAKE PAD WEAR

Brake pad wear depends upon the severity of usage, the type of riding, and road conditions. (Generally, the pads will wear faster on wet and dirty roads.)

Check the cutout in each pad.

If either pad is worn to the cutout, replace both pads as a set.

##### Rear brake

Check the cutout in each pad.

If either pad is worn to the cutout, replace both pads as a set.



Rear brake



### 3. INSPECTION/ADJUSTMENT

---

#### Combination Braking System (CBS)

Combination Braking System , the rider's action of depressing the rear brake lever applies both front and rear brakes, The amount of each brake applied is determined by CBS pump.

Depressing the front brake lever only applies the front brake.

- ① Rear brake lever
- ② the master cylinder
- ③ the brake tubing
- ④ the brake caliper
- ⑤ the brake disc
- ⑥ CBS Pump

#### CBS Diagram

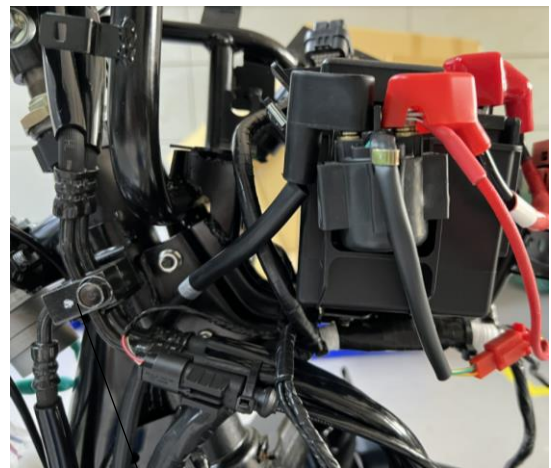
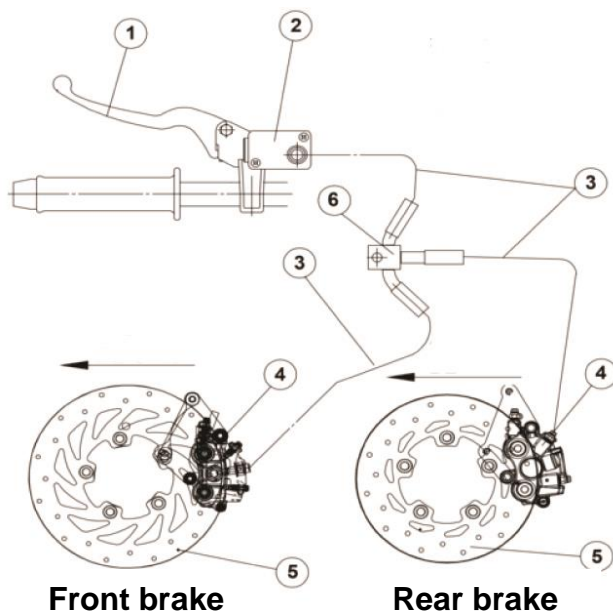

Three-limb Tube



### 3. INSPECTION/ADJUSTMENT

#### SUSPENSION

##### FRONT

Check the action of the front shock absorbers by compressing them several times.  
Check the entire shock absorber assembly for oil leaks, looseness or damage.



##### REAR

Each shock absorber assembly is equipped with a spring preload adjusting ring.  
Adjust the spring preload as follows.  
To increase the spring preload and thereby harden the suspension, turn the adjusting ring on each shock absorber assembly in direction (a). To decrease the spring preload and thereby soften the suspension, turn the adjusting ring on each shock absorber assembly in direction (b). Align the appropriate notch in the adjusting ring with the position indicator on the shock absorber.

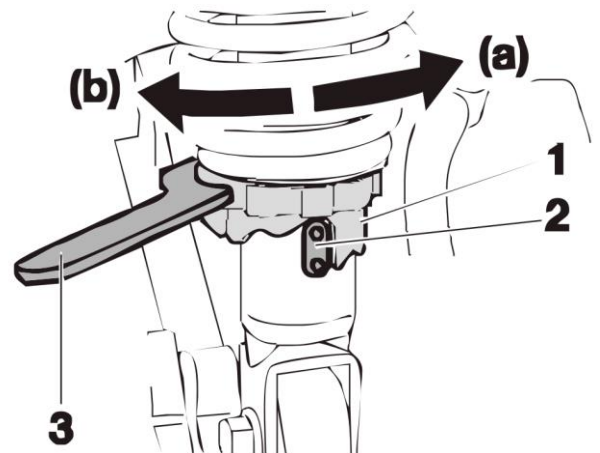



### 3. INSPECTION/ADJUSTMENT

#### NUTS/BOLTS/FASTENERS

Check all important chassis nuts and bolts for looseness.

Tighten them to their specified torque values if any looseness is found.

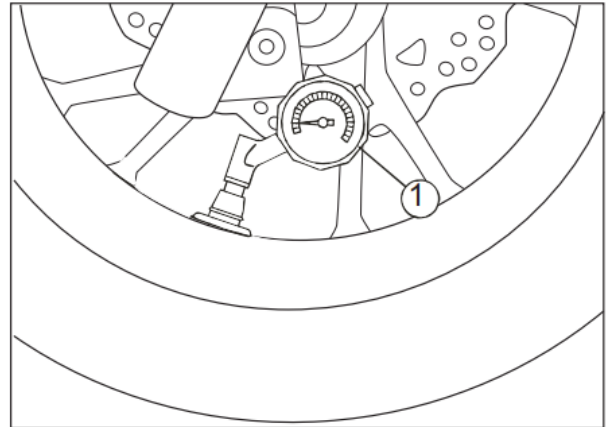

#### WHEELS/TIRES

Check the tires for cuts, imbedded nails or other damages.

Check the tire pressure.

\* •Tire pressure should be checked when tires are cold.

#### Tire Pressure

	1 Rider	1 Rider (with passenger)
Front	1.75 kg/cm <sup>2</sup>	1.75 kg/cm <sup>2</sup>
Rear	2.00kg/cm <sup>2</sup>	2.25 kg/cm <sup>2</sup>

#### Tire Size:

Front 110/70-14  
Rear 130/70-13

Check the front axle nut for looseness.  
Check the rear axle nut for looseness.  
If the axle nuts are loose, tighten them to the specified torques.

#### Torque:

Front axle nut : 65 N-m  
Rear axle nut : 120 N-m



#### STEERING HANDLEBAR

Raise the front wheel off the ground and check that the steering handlebar rotates freely.

If the handlebar moves unevenly, binds, or has vertical movement, adjust the steering head bearing.



## 3. INSPECTION/ADJUSTMENT

---

### SIDE STAND

Your scooter's side stand is not only necessary when you park, but it contains an important safety feature. This feature cuts-off the ignition if you try to ride the scooter when the side stand is down. Perform the following side stand inspection.



### INTERLOCK FUNCTION CHECK

Check the side stand ignition cut-off system,

1. Place the scooter on its center stand.
2. Put the side stand up and start the engine.
3. Lower the side stand. The engine should stop as you put the side stand down.

\* If the side stand system does not operate as described, see your KYMCO dealer for service.



**4. LUBRICATION SYSTEM**

---

---

**LUBRICATION SYSTEM**

---

**SERVICE INFORMATION ..... 4-2**

**TROUBLESHOOTING ..... 4-2**

**ENGINE OIL/OIL FILTER ..... 4-3**

**OIL PUMP ..... 4-4**

# 4. LUBRICATION SYSTEM

## LUBRICATION SYSTEM

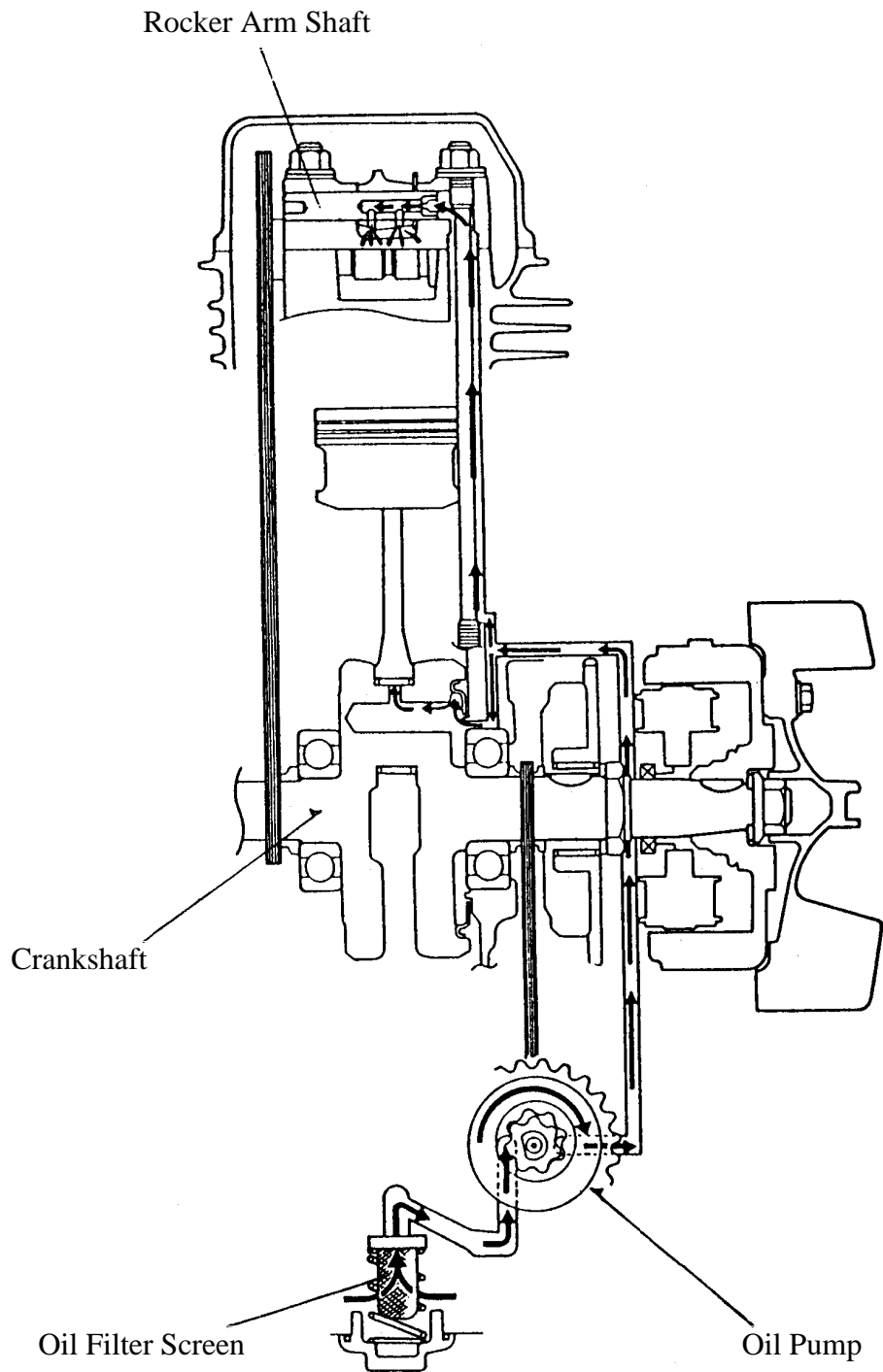

## 4. LUBRICATION SYSTEM

---

### SERVICE INFORMATION

#### GENERAL INSTRUCTIONS

- The maintenance of lubrication system can be performed with the engine installed in the frame.
- Use care when removing and installing the oil pump not to allow dust and foreign matters to enter the engine and oil line.
- Do not attempt to disassemble the oil pump. The oil pump must be replaced as a set when it reaches its service limit.
- After the oil pump is installed, check each part for oil leaks.

#### SPECIFICATIONS

Item		Standard (mm)	Service Limit (mm)
Oil pump	Inner rotor-to-outer rotor clearance	—	0.12
	Outer rotor-to-pump body clearance	—	0.12
	Rotor end-to-pump body clearance	0.05~0.10	0.2

#### TROUBLESHOOTING

##### Oil level too low

- Natural oil consumption
- Oil leaks
- Worn or poorly installed piston rings
- Worn valve guide or seal

##### Poor lubrication pressure

- Oil level too low
- Clogged oil filter or oil passages
- Not use the specified oil

## 4. LUBRICATION SYSTEM

### ENGINE OIL/OIL FILTER

#### OIL LEVEL

- \* 
  - Place the motorcycle upright on level ground for engine oil level check.
  - Run the engine for 2~3 minutes and check the oil level after the engine is stopped for 2~3 minutes.

Remove the oil dipstick and check the oil level with the oil dipstick.

If the level is near the lower level, fill to the upper level with the specified engine oil.



#### OIL CHANGE

Remove the oil filter screen cap located on the bottom of the engine to drain the engine oil thoroughly.

- \* 
 The engine oil will drain more easily while the engine is warm.



Oil Filter Screen Cap

After the oil has been completely drained, check the filter screen O-ring for damage and replace if necessary.

Install the oil filter screen, spring and filter screen cap.

**Torque:** 1.5kg-m

Fill with the specified SAE10W40#, API: SL engine oil to the proper level.

Oil Capacity: At disassembly : 0.90 liter  
 At change : 0.8 liter



O-ring

Check for oil leaks and then start the engine and let it idle for few minutes.  
 Recheck the oil level.

### OIL PUMP

#### REMOVAL

Remove the A.C. generator flywheel.





## 4. LUBRICATION SYSTEM

Remove the stator and the crank position sensor together.  
Remove the 8 bolts, and remove the starter clutch cover.

starter clutch cover

CPS

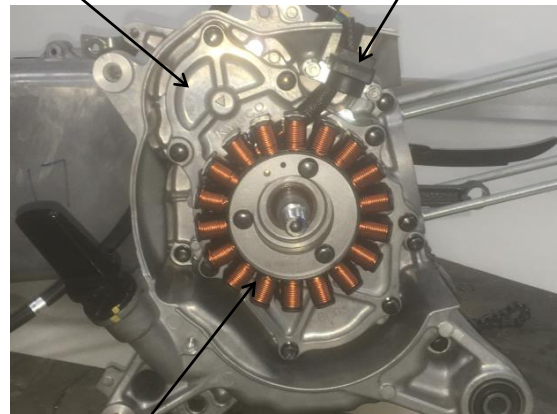

Stator

Gasket

Remove the gasket and dowel pins.  
Remove the starter idle gear and starter clutch.

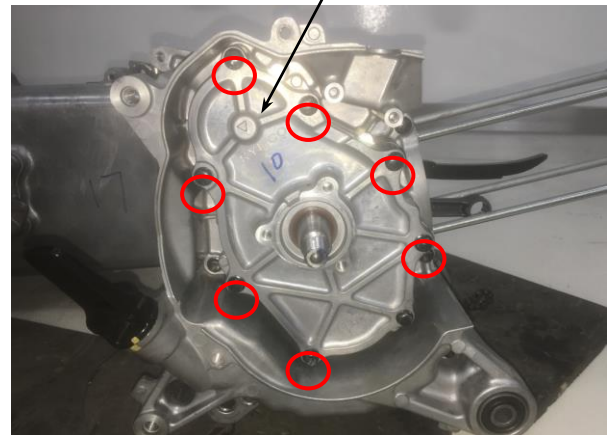

starter idle gear

starter clutch

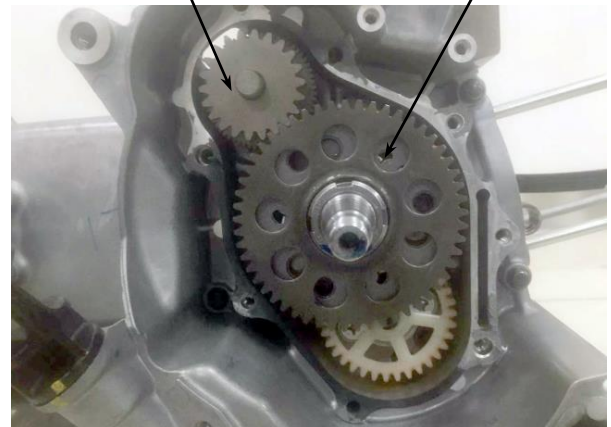

Remove the circlip and oil pump drive gear.



oil pump drive gear

## 4. LUBRICATION SYSTEM

Remove the 2 bolts and the oil pump cover.

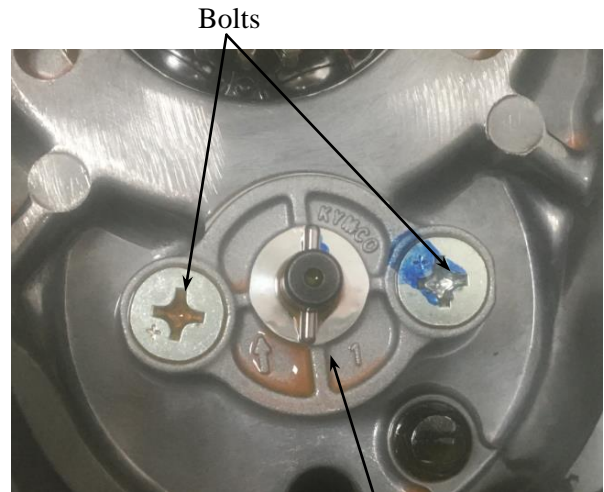

Bolts

Oil Pump Cover

Remove the Oil pump shaft .



Oil Pump Shaft

Remove the oil pump.



Oil Pump





## 4. LUBRICATION SYSTEM

### INSPECTION

Measure the right cover(pump body)-to-outer rotor clearance.

**Service Limit:** 0.12mm

Outer Rotor

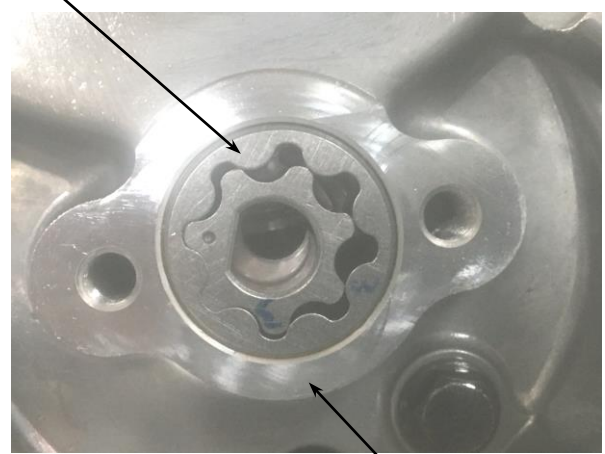

right cover(Pump Body)

Measure the inner rotor-to-outer rotor clearance.

**Service Limit:** 0.12mm

Outer Rotor

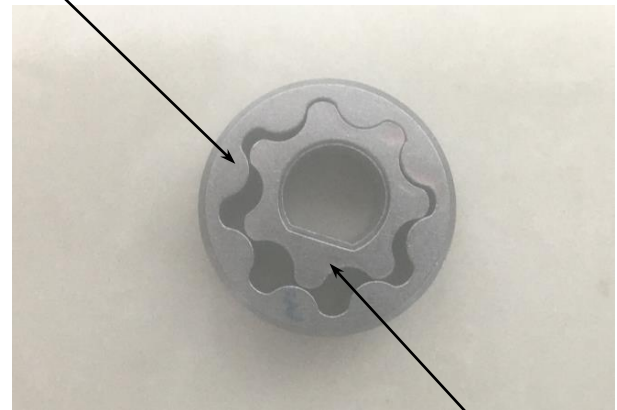

Inner Rotor

Measure the rotor end-to-pump body clearance.

**Service Limit:** 0.2mm

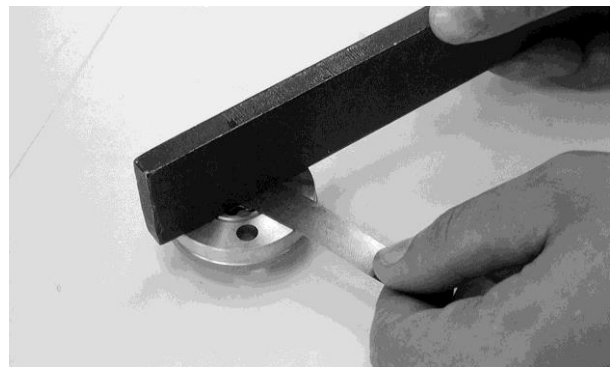

## 4. LUBRICATION SYSTEM

### INSTALLATION

Install the outer rotor, inner rotor  
Install the oil pump into the crankcase.

\* Install the oil pump with the "O" mark the pump body facing up and fill the oil pump with engine oil before installation.

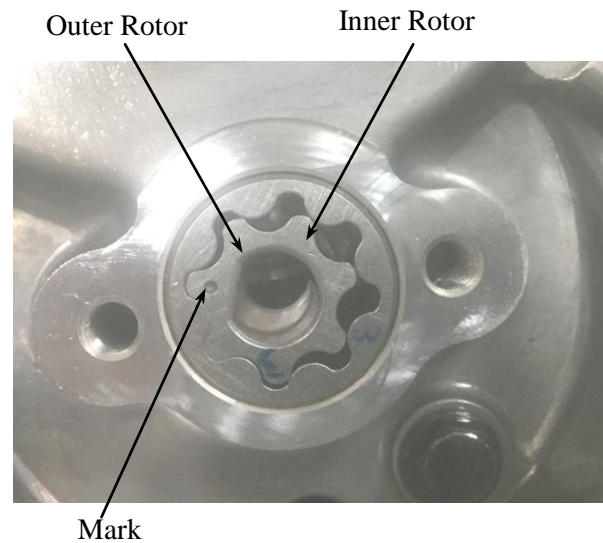

Install the Oil pump shaft.

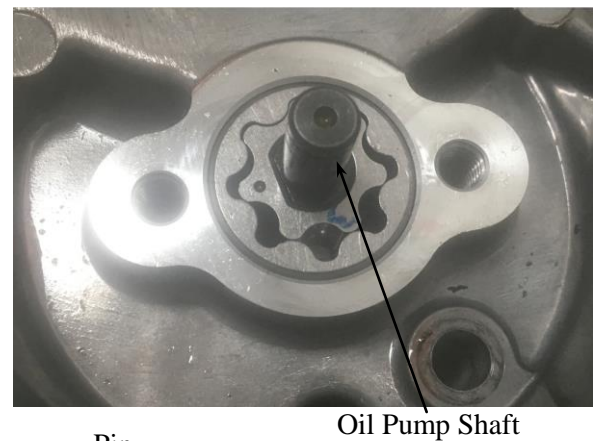

Install the oil pump cover with the arrow facing up .  
Install the dowel pin.

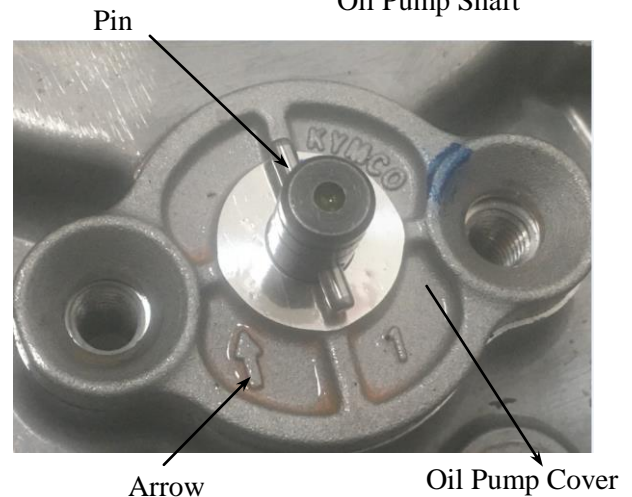

## 4. LUBRICATION SYSTEM

After the oil pump is installed, tighten the two mounting bolts.

**Torque:** 1.0kg-m



Bolts

Install the pump driven gear.  
Install the circlip.

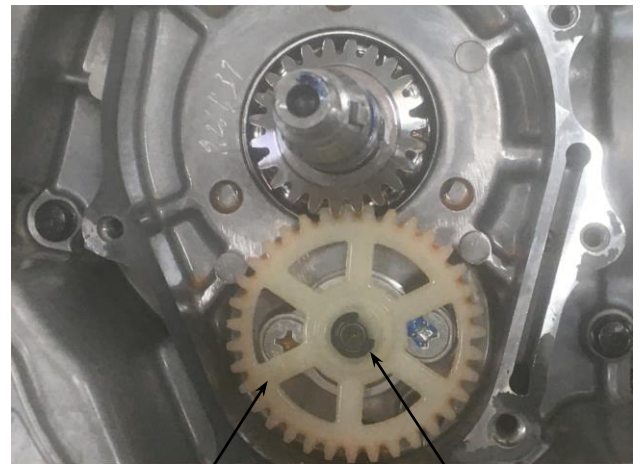

Driven gear

Circlip

Install the starter clutch and tighten the nut.

**Torque:** 9.0~10.0kg-m

Install the starter idle gear.



Starter idle gear

Starter clutch

## 4. LUBRICATION SYSTEM

Install the gasket and dowel pins.

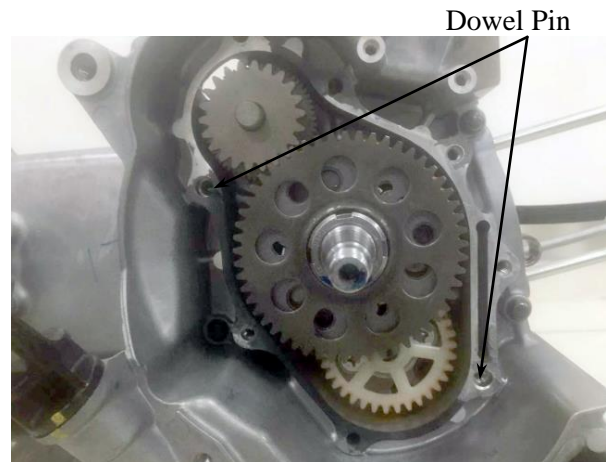

Install the starter clutch cover and tighten the 8 bolts.

**Torque:** 0.9kg-m

\* Diagonally tighten the bolts in 2 ~ 3 times.

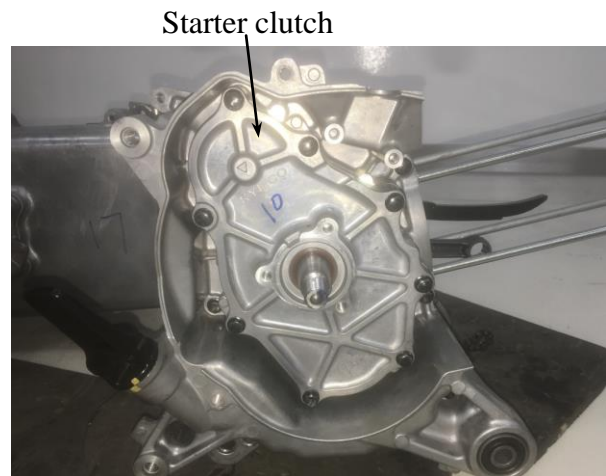

Install the stator and the crank position sensor together.

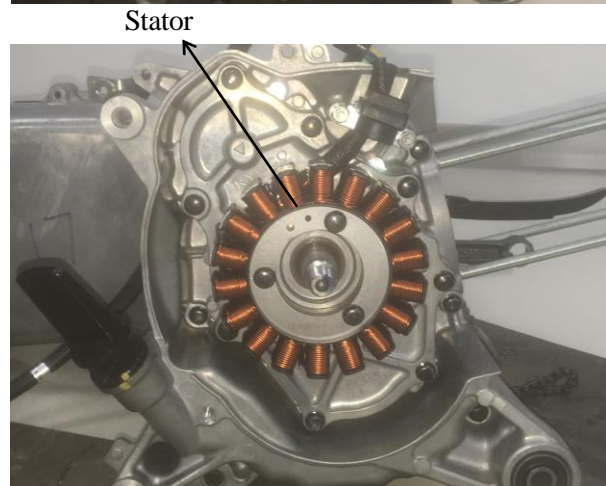

Install the A.C. generator flywheel and tighten the nut.

**Torque:** 5.0~6.0kg-m

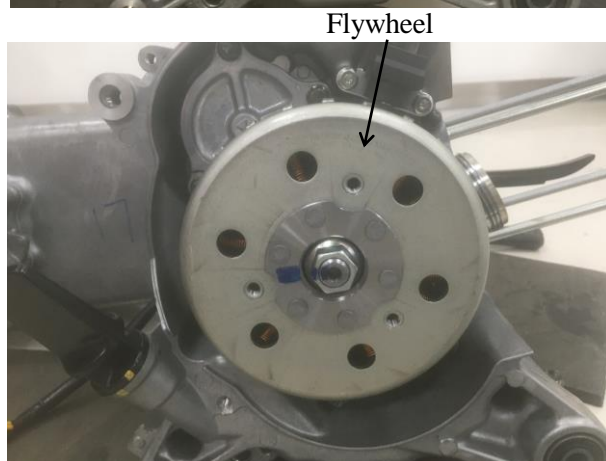



## 4. LUBRICATION SYSTEM

---

Install the fan and tighten the 3 bolts.



Install the fan cover and tighten the 4 bolts.

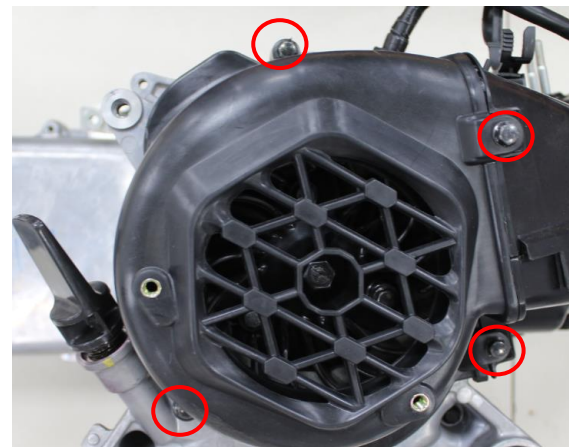

## **5. FUEL INJECTION SYSTEM**

---

### FUEL INJECTION SYSTEM

SYSTEM DIAGRAM .....	5 - 1
SYSTEM LOCATION.....	5 - 2
SERVICE INFORMATION .....	5 - 3
TROUBLESHOOTING .....	5 - 4
CHECK ENGINE LAMP (CELP).....	5 - 5
HOW TO SHOW THE FAILURE CODE.....	5 - 6
FAILURE CODES CHART .....	5 - 7
ECU .....	5-11
FUEL PUMP .....	5-12
T-MAP & TPS.....	5-13
WTS.....	5-14
INJECTOR .....	5-14
O <sup>2</sup> SENSOR .....	5-15



## 5. FUEL INJECTION SYSTEM

### INJECTION SYSTEM

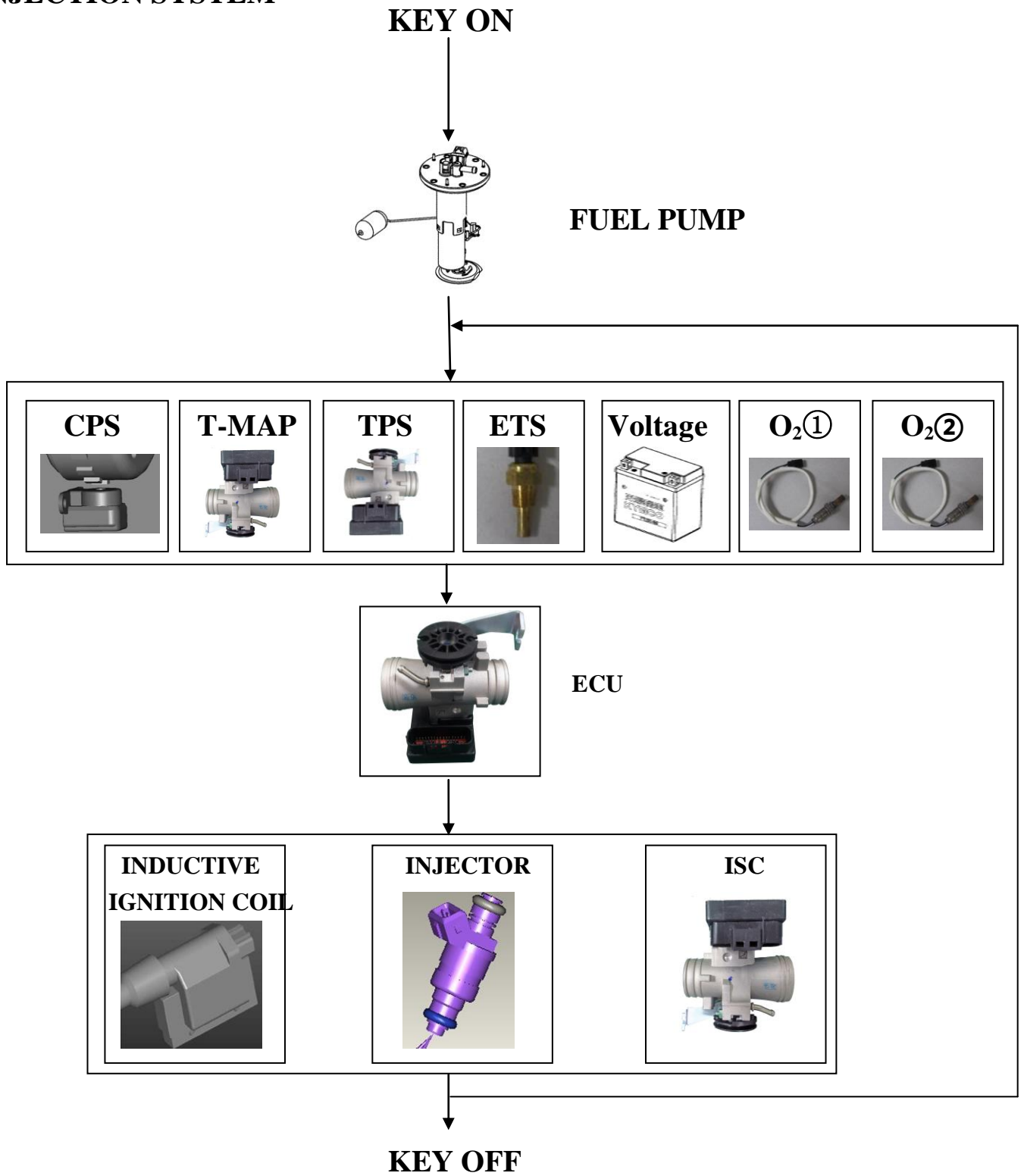

# 5. FUEL INJECTION SYSTEM

## Parts Location

- 01: Inductive Ignition coil
- 02: Fuel pump
- 03: ECU
- 04: Fuel Injector
- 05: ETS sensor
- 06: T-MAP sensor
- 07: ISC
- 08: TPS
- 09: CPS
- 10: O<sub>2</sub> sensor

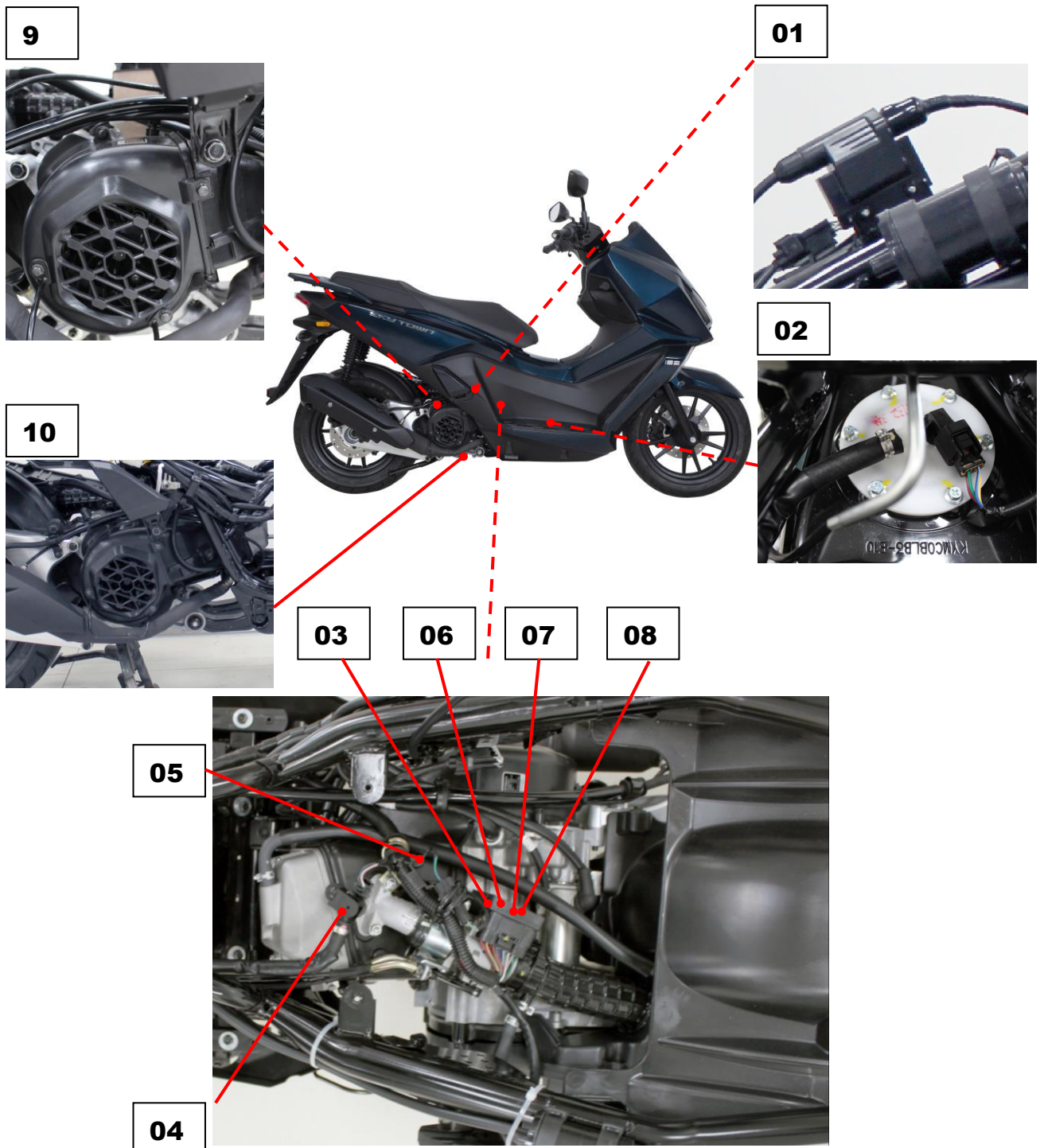



## 5. FUEL INJECTION SYSTEM

### SERVICE INFORMATION

#### GENERAL INSTRUCTIONS

\* Gasoline is very dangerous. When working with gasoline, keep sparks and flames away from the working area.  
Gasoline is extremely flammable and is explosive under certain conditions. Be sure to work in a well-ventilated area.

- Disconnect the cables of the battery when the engine is running, which could lead to ECU damage.
- Connect the harness positive (+) cable to the battery negative (-) terminal or connect the harness negative (-) to the battery positive (+) terminal, which could lead to ECU damage.
- Always keep fuel over 750 cc in fuel tank.

#### SPECIFICATIONS

Item		Standard	
Charging voltage of battery		13.5 ~ 14.5V	
Voltage from the ECU to sensor		5 ±0.1V	
Fuel injector resistance (20 °C/68 °F)		12 ±0.6Ω	
Engine temperature sensor resistance		11.529 ±10% kΩ(25 °C)	
Throttle position sensor voltage		Idle (0 °) = 0.50 ±0.1V Throttle fully (90 °/4.0V over)	
Fuel pump resistance		About 2Ω	
Fuel unit resistance (20 °C/68 °F)		F: about 100Ω E: about 1100Ω	
O2 sensor	O2 sensor heater resistance	15Ω	
	Voltage	Air/Fuel <14.7 (Rich)	>0.7V
		Air/Fuel >14.7 (Lean)	<0.18V
Crank position sensor (Pulser) resistance		96 ~ 144Ω	
Inductive ignition coil resistance (20 °C/68 °F)		0.60 ~ 0.66Ω	
Idle speed		1600 rpm	

## **5. FUEL INJECTION SYSTEM**

---

### **TROUBLESHOOTING**

#### **Engine won't start**

- Battery voltage too low
- Fuel level too low
- Pinched or clogged fuel hose
- Faulty fuel pump operating system
- Clogged fuel filter (fuel pump)
- Clogged fuel injector
- Faulty spark plug or wrong type
- Cut by ECU due to angle detect sensor or incorrect function

#### **Backfiring or misfiring during acceleration**

- Ignition system malfunction

#### **Poor performance (drive ability) and poor fuel economy**

- Pinched or clogged fuel hose
- Faulty fuel injector

#### **Engine stall, hard to start, rough idling**

- Intake air leak
- Fuel contaminated/deteriorated
- Pinched or clogged fuel hose
- Idle speed misadjusted

## **5. FUEL INJECTION SYSTEM**

---

### **CHECK ENGINE LAMP (CEL)**

Open the Ignition switch, the CEL indicator will illuminate always.

After starting it will crush out.

If there is any malfunction, the CEL indicator will still illuminate, please take your scooter to a KYMCO dealer for service as soon as possible.



## 5. FUEL INJECTION SYSTEM

### Failure Code Chart

No	Diagnose code	Failure Code	Pcode	備註
1	D1	B0099	B0099 Roll sensor Voltage High	
2	F0	C0064	C0064 Roll sensor malfunction	
3	A1	P0030	P0030 O2 sensor heater malfunction	
4	A2	P0031	P0031 O2 sensor heater Voltage Low	
5	A3	P0032	P0032 Lambda sensor heater Voltage High	
6	A4	P0105	P0105 MAP sensor malfunction	
7	A5	P0107	P0107 MAP sensor Voltage Low	
8	A6	P0108	P0108 MAP sensor Voltage High	
9	A7	P0110	P0110 Intake air temperature sensor malfunction or Voltage High	
10	A8	P0111	P0111 Intake air temperature circuit malfunction	
11	A9	P0112	P0112 Intake air temperature sensor Voltage Low	
12	D6	P0113	P0113 Intake air temperature sensor Voltage High	
13	AA	P0114	P0114 Intake air temperature intermittent failure	
14	AB	P0115	P0115 Engine Temperature Sensor malfunction or Voltage High	
15	AC	P0117	P0117 Engine Temperature Sensor Voltage Low	
16	AD	P0118	P0118 Engine Temperature Sensor Voltage High	
17	AE	P0119	P0119 Engine Temperature intermittent failure	
18	AF	P0120	P0120 Throttle Position Sensor malfunction or Voltage Low	
19	B0	P0121	P0121 Throttle position sensor adaptation is out of range	
20	B1	P0122	P0122 Throttle Position Sensor Voltage Low	
21	B2	P0123	P0123 Throttle Position Sensor Voltage High	
22	B3	P0124	P0124 Difference between the two last TPS acquisitions is out of range	
23	B4	P0130	P0130 O2 sensor signal malfunction	
24	B5	P0131	P0131 O2 sensor signal Voltage Low	
25	B6	P0132	P0132 O2 sensor signal Voltage High	
26	D7	P0171	P0171 System over lean or over rich (Too Lean)	
27	D8	P0172	P0172 System over lean or over rich (Too Rich)	
28	B7	P0200	P0200 Injection malfunction	
29	DA	P0201	P0201 Injection valve malfunction	
30	B8	P0217	P0217 Engine over temperature condition	
31	B9	P0219	P0219 CVT overspeed detected	
32	BA	P0230	P0230 Fuel pump malfunction	
33	BB	P0231	P0231 Fuel pump Voltage Low	
34	BC	P0232	P0232 Fuel pump Voltage High	
35	BD	P0260	P0260 Injection valve malfunction	
36	BE	P0261	P0261 Injection valve Voltage Low	

## 5. FUEL INJECTION SYSTEM

37	BF	P0262	P0262 Injection valve Voltage High	
38	BE	P0264	P0264 Injection valve Voltage Low	
39	BF	P0265	P0265 Injection valve Voltage High	
40	C0	P0335	P0335 Crankshaft sensor malfunction	
41	C1	P0350	P0350 Ignition malfunction or Voltage Low	
42	C2	P0351	P0351 Ignition Voltage High	
43	DB	P0412	P0412 Secondary air injection system malfunction	
44	C3	P0480	P0480 Fan Relay/Circuit malfunction	
45	F1	P0484	P0484 Fan Relay/Circuit Voltage High	
46	F2	P0485	P0485 Fan Relay/Circuit Voltage Low	
47	DE	P0500	P0500 Vehicle Speed Sensor malfunction	
48	D9	P0501	P0501 Vehicle Speed Sensor malfunction	
49	C4	P0505	P0505 ISAV idle speed actuator valve malfunction	
50	C5	P0508	P0508 ISAV idle speed actuator valve Voltage Low	
51	C6	P0509	P0509 ISAV idle speed actuator valve Voltage High	
52	DF	P0511	P0511 ISC stepper motor malfunction	
53	F3	P0560	P0560 Battery voltage VBK malfunction	
54	F4	P0561	P0561 Battery voltage VBK malfunction	
55	C7	P0562	P0562 Battery voltage VBK too Low	
56	C8	P0563	P0563 Battery voltage VBK too High	
57	DC	P0603	P0603 ECU memory error	
58	F7	P0615	P0615 Starter Relay malfunction	
59	F8	P0616	P0616 Starter Relay Voltage Low	
60	F9	P0617	P0617 Starter Relay Voltage High	
61	C9	P0650	P0650 MIL Voltage High	
62	CA	P0700	P0700 Engine overspeed detected	
63	CB	P1110	P1110 Roll sensor Voltage High	
64	CC	P1111	P1111 Roll sensor malfunction or Voltage Low	
65	DD	P1205	P1205 MAP sensor malfunction	
66	CD	P1410	P1410 AISV system break down	
67	E0	P1505	P1505 ISC system malfunction	
68	E1	P1521	P1521 VACS Valve circuit malfunction	
69	CE	P1630	P1630 Roll sensor circuit malfunction	
70	CF	P2187	P2187 Lambda control too High	
71	D0	P2188	P2188 Lambda control too Low	
72	D4	P2300	P2300 Ignition malfunction or Voltage Low	
73	D5	P2301	P2301 Ignition malfunction or Voltage High	
74	D4	P2303	P2303 Ignition malfunction or Voltage Low	
75	D5	P2304	P2304 Ignition malfunction or Voltage High	
76	D3	P263A	P263A MIL Voltage Low	
77	D2	P263B	P263B MIL Voltage High	

## 5. FUEL INJECTION SYSTEM

78		C006A	C006A Accelerometer identifier diagnosis Failure of self test	
79		P0106	P0106 Stuck MAP signal	
80		P0116	P0116 TCO out of range	
81		P0133	P0133 Oxygen sensor switching time monitoring Implausible oxygen sensor switching time	
82		P0134	P0134 Lambda sensor diagnosis Open signal	
83		P0135	P0135 Lambda sensor heater plausibility diagnosis Lambda sensor heater implausible operation	
84		P016B	P016B Lambda controller Excessive positive deviation of lambda controller	
85		P016C	P016C Lambda controller Excessive negative deviation of lambda controller	
86		P0300	P0300 Multiple misfire A diagnosis	
87		P0313	P0313 Misfire fuel tank low	
88		P0314	P0314 Misfire A diagnosis	
89		P0336	P0336 Crankshaft wrong tooth number diagnosis Additional CRK tooth detected	
90		P0339	P0339 Crankshaft sensor Additional edges inside filtering period	
91		P0410	P0410 Secondary Air Valve Plausibility diagnosis Secondary Air Valve Unplausible	
92		P0413	P0413 Secondary air valve diagnosis Open signal	
93		P0414	P0414 Secondary air valve diagnosis Signal shorted to ground	
94		P0444	P0444 Canister purge solenoid diagnosis Open signal	
95		P0458	P0458 Canister purge solenoid diagnosis Signal shorted to ground	
96		P0459	P0459 Canister purge solenoid diagnosis Signal shorted to battery	
97		P0503	P0503 Intermittent vehicle speed signal from CAN diagnosis	
98		P0519	P0519 Stepper plausibility diagnosis Implausible stepper control	
99		P0661	P0661 Variable intake pipe diagnosis Signal shorted to battery	
100		P0662	P0662 Variable intake pipe diagnosis Signal shorted to ground	
101		P0663	P0663 Variable intake pipe diagnosis Signal open	
102		P0894	P0894 CVT overspeed Transmission component slipping	
103		P2A00	P2A00 Oxygen sensor out of range	
104		U0241	U0241 Head lamp diagnosis Signal shorted to ground	
105		U1601	U1601 CAN Bus off diagnosis Bus off	
106		U1605	U1605 CAN control unit diagnosis for checked received messages Fail	
107		P0643	P0643 Reference voltage diagnosis 1 Signal shorted to battery	
108		P0608	P0608 Reference voltage diagnosis 1 Signal shorted to ground or open	

# 5. FUEL INJECTION SYSTEM

## ECU

There are 34 pins attaching the ECU.

### ECU PIN FUNCTION

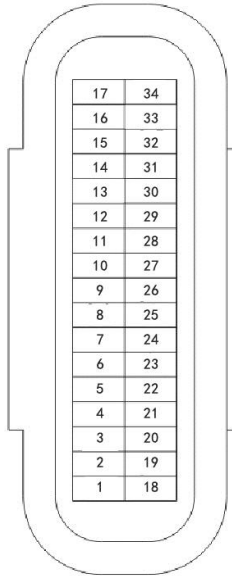

01	PGND1	13	FUEL PUMP RELAY	25	CPS(-)
02		14		26	SGND
03	HEGO HEAT_UP	15	RPM	27	HEGO SENSOR_UP
04		16		28	S&SLED/HL RELAY
05	INJ	17		29	CAN_L
06		18	PGND2	30	VBD
07	HEGO HEAT_DOWN	19	MIL	31	TILT
08	CPS(+)	20	IGNITION COIL	32	VSSENS
09		21		33	
10	HEGO SENSOR_DOWN	22		34	VEHICLE SPEED
11	VBK	23	ENGINE TEMPERATURE		
12	CAN_H	24			
PIN	FUNCTION	PIN	FUNCTION	PIN	FUNCTION

ECU

MAP content (edition issue no.)

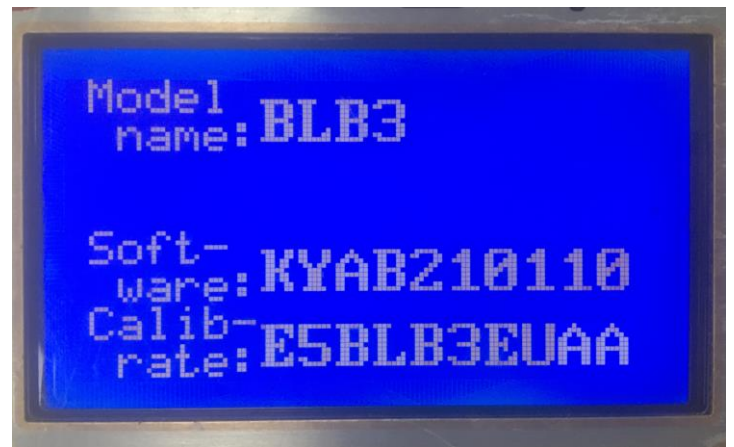

Prohibited to adjust and remove the throttle body idle screw



## 5. FUEL INJECTION SYSTEM

### FUEL PUMP

Connect the meter (+) probe to the red/black wire and the meter (-) probe to the green wire to measure the voltage from the ECU input to fuel pump unit.

Standard : 8~16 V (Battery volt)

Fuel Pump Standard Pressure: 2.5Kg/cm<sup>2</sup> (bar)

To measure the resistance of the fuel pump to see if it is short circuit or not.

Fuel Pump Inspection :

1. Fuel Pump Resistance:

>>>About : 2Ω

2.If there is no continuity replace it

Fuel Hose



Connector

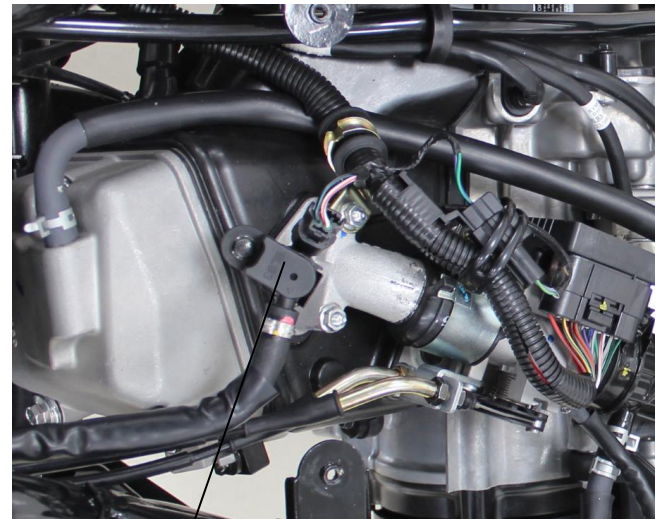

Fuel Injector

### INJECTOR

Measure the resistance of the Injector

Standard (20°C/68°F): 10.6~15.9Ω





## 5. FUEL INJECTION SYSTEM

### T-MAP(Manifold Air Temperature Pressure) Sensor

Connect the Fi diagnostic tool.

Enter the Data Analyze

Check if the manifold pressure data is malfunction.

Turn the ignition switch to the “ON” position.

If data is incorrect, and the T-map sensor is problem.



**Standard : 101.3 ±3 kpa on sea altitude**

The ambient pressure drop is about 12Kpa according to the altitude raises.

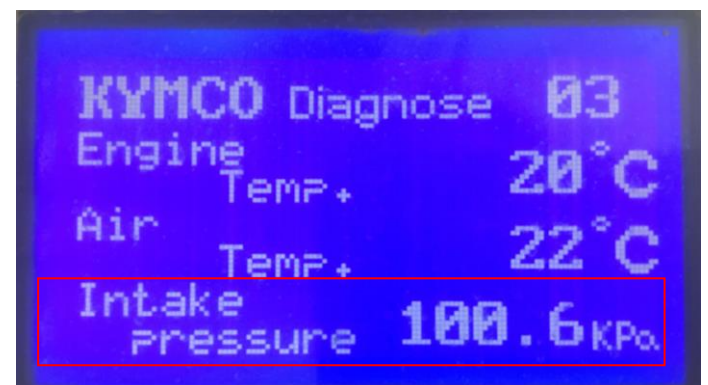

### TPS (Throttle Position Sensor)

Enter the Data Analyze

Check if the TPS position data is malfunction.

Turn the ignition switch to the “ON” position.

If data is incorrect even the Idle and throttle fully, the TPS is problem.



**Standard :**

Idle ~0 °                      0.5V ±0.1

Throttle fully ~90 °        > 4.0V

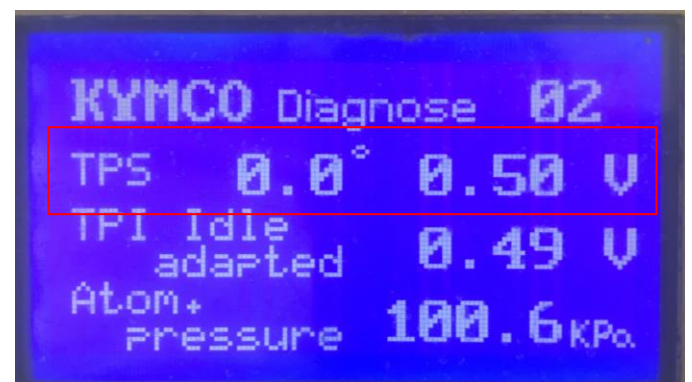

## 5. FUEL INJECTION SYSTEM

### ETS (Engine Temperature Sensor)

Connect the meter (+) probe to the V/G wire and the meter (-) probe to the G/L wire to measure the voltage

**Standard :  $5 \pm 0.25$  V**

Measure the resistance of the ETS

**Standard  $11.529 \pm 10\%$  k $\Omega$ (25 °C)**

### CPS

Measure the resistance of the Injector Measure the resistance between the blue/white and green/white wire terminals.

**Standard : 96~144 $\Omega$**

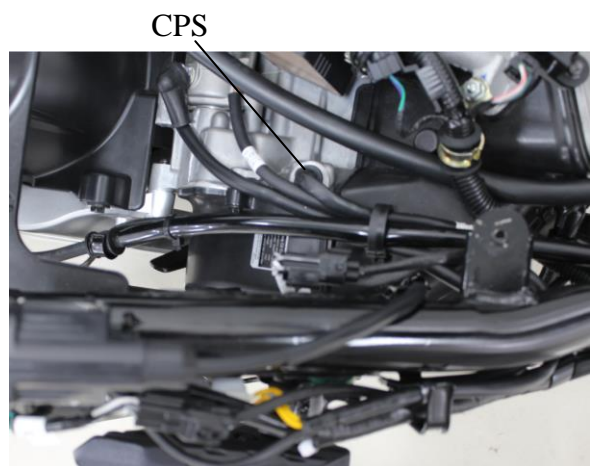

CPS Connector



## 5. FUEL INJECTION SYSTEM

### O2 SENSOR

Measure the resistance of the O2 sensor heater.  
(2 white wire pin)

Standard (20°C/68°F): 6.7 ~9.5Ω



Connect the KYMCO Fi diagnostic tool.  
Enter the Data Analyze  
Check Page 05  
Turn the ignition switch to the “ON” position.  
Starting engine till the O2 heater activation is 2.

If data is incorrect, the O2 sensor is problem.

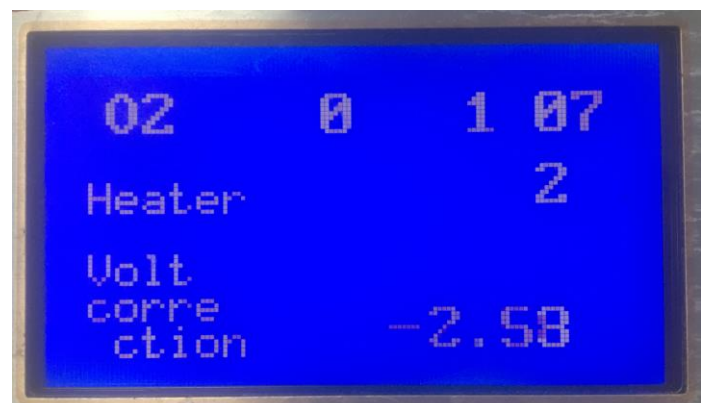
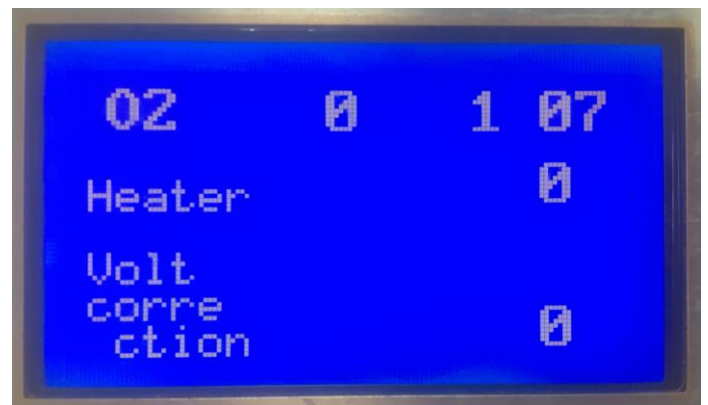



## Fi Diagnostic Tool Operation Instructions Part No. 3620A-LEB2-E00

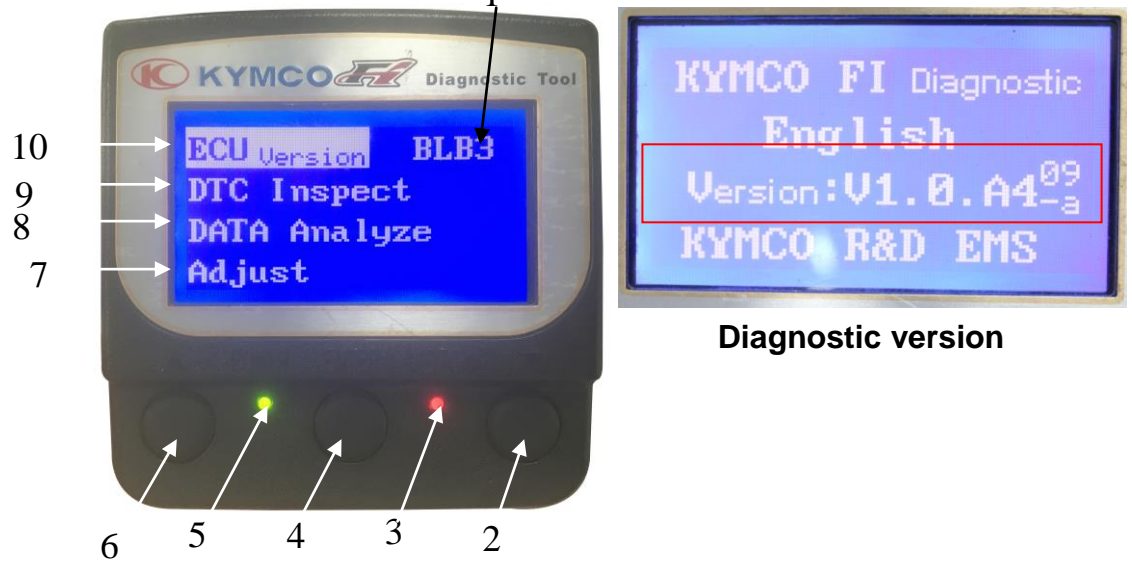

- |                                 |                                      |
|---------------------------------|--------------------------------------|
| 1 Model No.                     | 6 UP Button                          |
| 2 Down Button                   | 7 Adjust(TIP and ABV reset function) |
| 3 DTC indicator (Failure codes) | 8 DATA Analyze                       |
| 4 Enter or Exit                 | 9 DTC Inspect                        |
| 5 Power indicator               | 10 ECU Version                       |

**Note:**

Use the sub-cord, OBD diagnostics, CAN LINKER(3620A-LGC7-E00) or Integrated Linker (3620A-AGD7-900),connector (part number:36205-LFA7- E00) to connect between vehicle and diagnostic tool.

**Diagnostic tool**

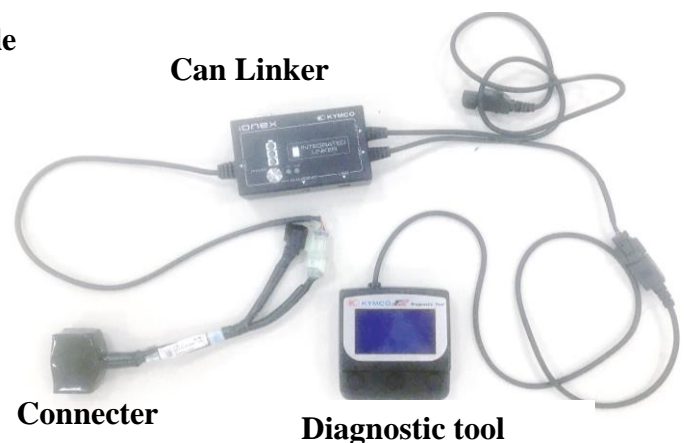
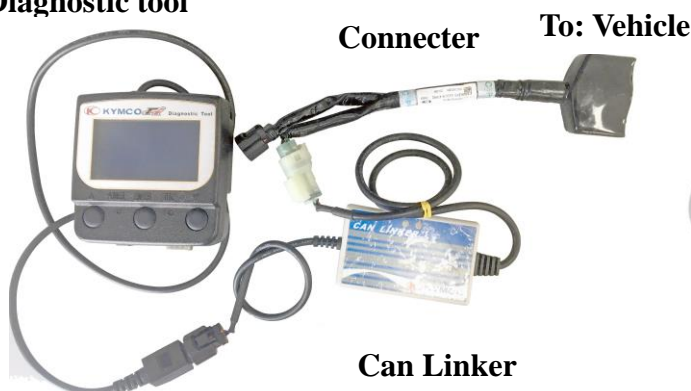

## 5. FUEL INJECTION SYSTEM

### DTC INSPECTION

Connect Fi diagnostic tool with the connector of harness wire located beside the Battery.

- \* •Fi diagnostic tool is electrically After Connect Fi diagnostic tool with the connector of harness,
- The data can only be read after the main switch is turned on

Press the " Enter " button

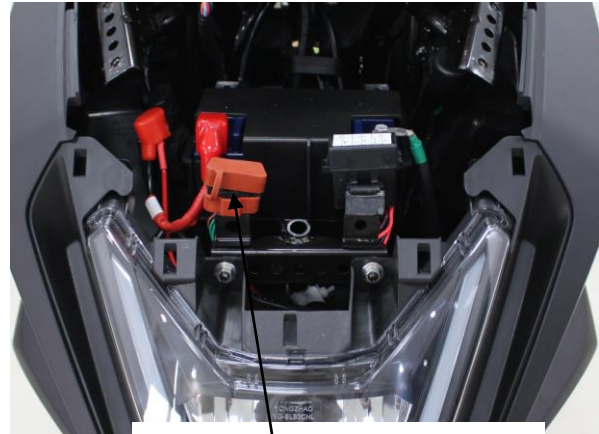

Connector (OBD)



Check the software version

Press the " Enter " button and then turn to the first page.

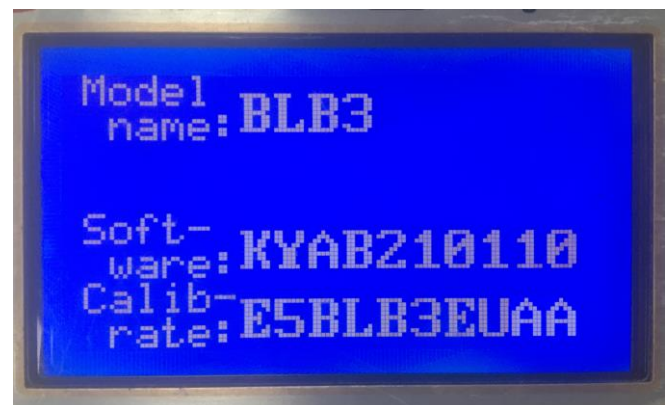

Press the " Down " button to enter the DTC Inspect.

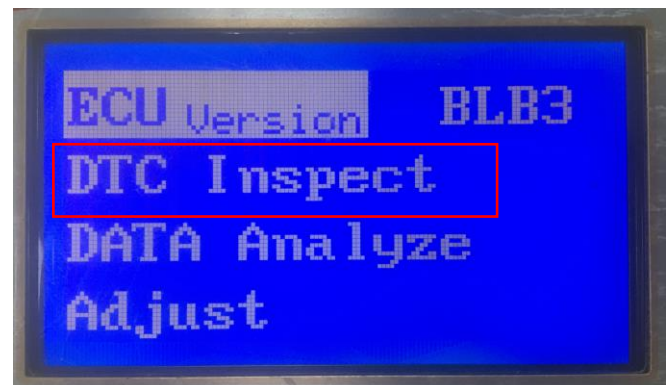

# 5. FUEL INJECTION SYSTEM

Press the "Enter" button to check the DTC number



Press the "Enter" button

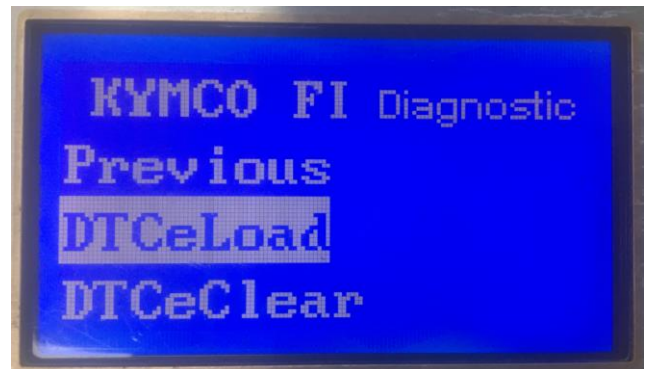

Press the "Enter" button



Display the DTC number of the DTC-List. Refer to DTC summary list.

Press the "Enter" button and then turn to the previous page



## 5. FUEL INJECTION SYSTEM

---

Press the "UP" button



Press the "Enter" button and then turn to the previous page.



Press the "UP" button

Press the "Enter" button and then turn to the first page.





## DTC CLEAR PROCEDURE

Choose " DTC Inspect "

Press the "Enter" button

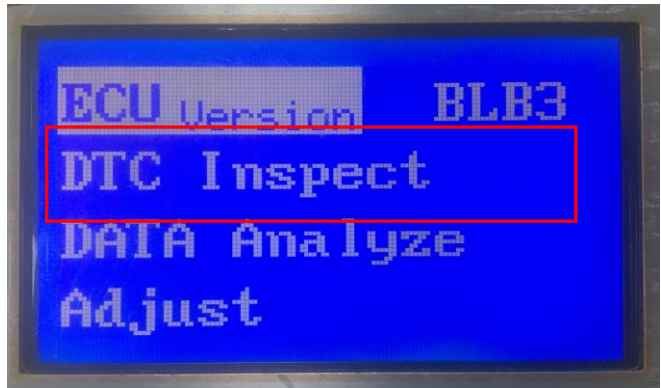

Choose " DTC Clear "

Press the "Enter" button

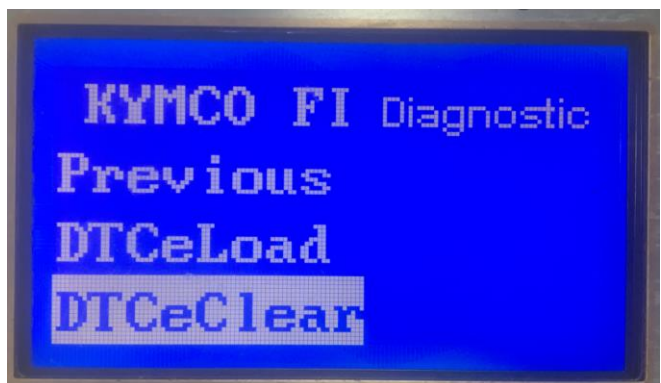

The DTC indicator is lighting at that time.



Clearing DTC until the DTC indicator is off.



### DATA ANALYSIS

Choose "Data Analyze"

Press the "Enter" button to enter page 01.

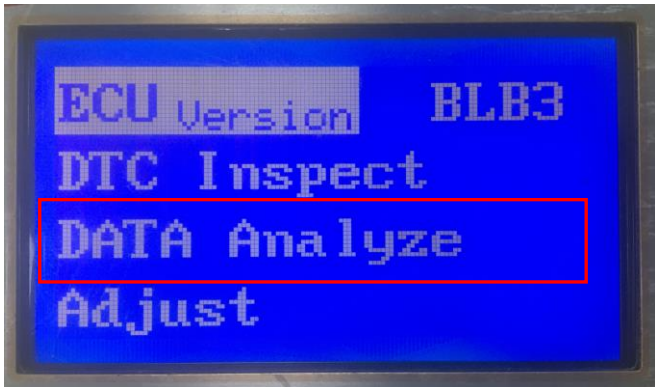

The figure includes the engine speed, idle speed and the battery voltage.

Refer to standard specification.

Press the "Down" button to enter page 02.

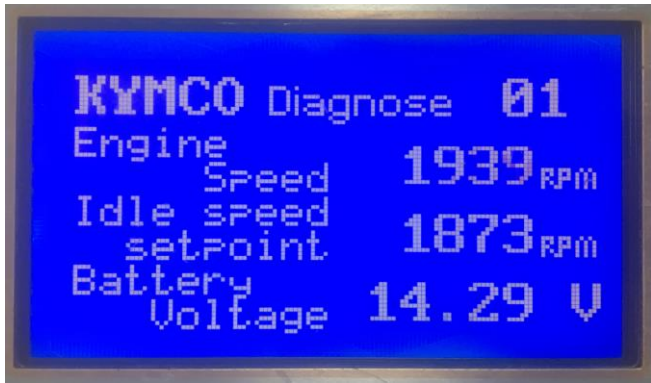

The figure includes TPS position, TPI idle adapted voltage and TPI WOT adapted atmosphere pressure

Refer to standard specification.

Press the "Down" button to enter page 03.

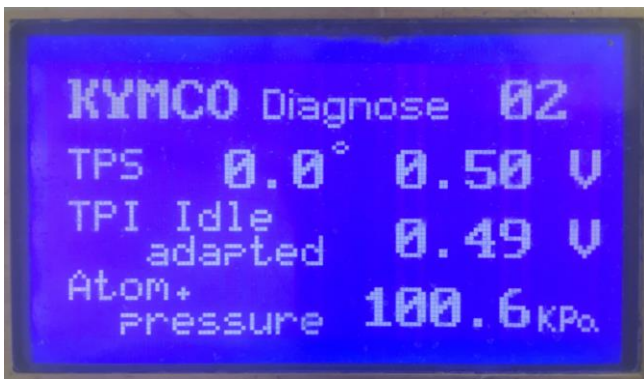

The figure includes engine working temperature, Air temperature and Intake pressure.

Refer to standard specifications

Press the "Down" button to enter page 04.

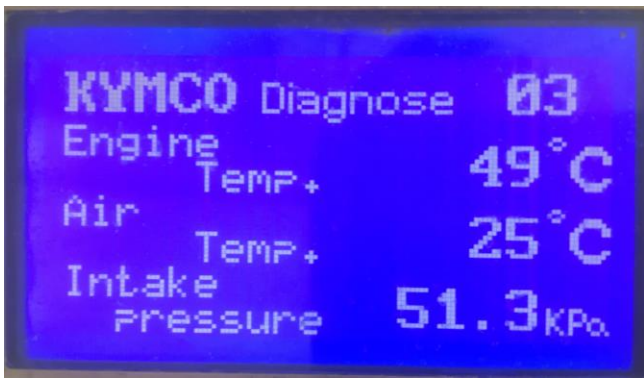

## 5. FUEL INJECTION SYSTEM

The figure includes ISC and ISC learn step.  
 Refer to standard specification.  
 Press the "Down" button to enter page 05.



The figure includes Ignition Dwell duration,  
 fuel Injection duration and Ignition advance.

Refer to standard specification.

Press the " Down " button to enter page 06.



The figure includes ECU counter hours.

Refer to standard specification.

Press the " Down " button to enter page 07.

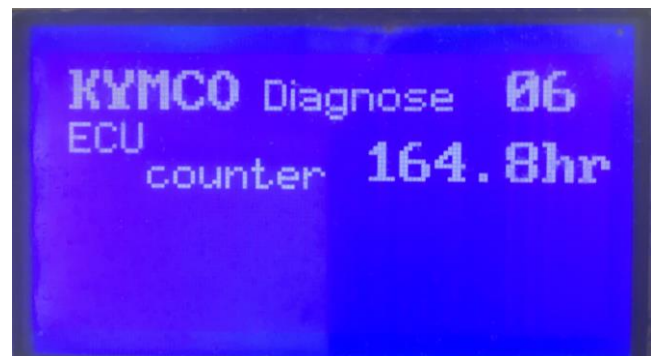

The figure includes O2 sensor heater and  
 O2 sensor correction.

Press the " UP " button to the first page.



# 5. FUEL INJECTION SYSTEM

## Skytown 125 E5 Diagnostic report

<b>SF :</b>		<b>Customer :</b>		<b>Eng. No:</b>	
<b>Production Date :</b>		<b>Service Date :</b>		<b>Mileage :</b>	

Reason of repair: Maintenance Breakdown

Item		Data	Reference	Memo
Version	ECU No			BLB3
	Hardware Ver			
	Software Ver		KYAB210110	
	Calibration Ver		E5BLB3EUAA	
DTC	Active			
	Occurred			
	History			
Stop	(Cool Engine) Engine			
	Air Temp.( °C)		Environ temp ±2 °C	
	Engine Temp.(Cooling)		Environ temp ±2 °C	
	Atom. Pressure (kpa.)		101.3 ±3 kpa	The ambient pressure drop about 12kpa at the altitude every 1000m raised
	Throttle Position (%)		0° / >92°	IDLE/Throttle fully
	Throttle Position (V)		0.5 ±0.1V / >4 V	IDLE/Throttle fully
	TPI Idle Mean (V)		0.5 ±0.1V	
	Battery Volt (V)		>12 V	
	ISCAdapMean (°)		+20%~-10%	
	Spark plug Type		LR7D	
	Accumulated Eng. Run Time (Hr)			
(Hot Engine) Before Repair	Engine Speed IDLE(rpm)		1600 ±100 rpm	
	Battery Volt (V)		>13 V	
	MAPSample (kPa)		42~ 48 kpa	
	Injection duration (ms)		2.0~3.0 ms	
	Ign. Advance (°)		3~ 17BTDC	
	Ign.Dwell duration (ms)		1.9~ 2.6ms	Battery Volt (V) 14V3.6~4.2ms, 12V4.09~4.66ms
	Air Temp.( °C)		environ.temp ±2 °C	
	Engine Temp. ( °C)		>105 °C	
	O2 sensor voltage (V)(Front)		0~1V	
	O <sup>2</sup> sensor heater(Front)		ON	
	O <sup>2</sup> sensor correct(Front)		-14%~+10%	
	O2 sensor voltage (V)(Rear)		0~1V	
	O <sup>2</sup> sensor heater(Rear)		ON	
	O <sup>2</sup> sensor correct(Rear)		-14%~+10%	
	ISC AngDurMech (°)		20% <ISC < 45%	>45% The scooter with exchange engine oil and clean throttlly body >50% The scooter must clean throttlly body
(Hot Engine) After Repair	Engine Speed IDLE(rpm)		1600 ±100 rpm	
	Battery Volt (V)		>13 V	
	MAPSample (kPa)		42~ 48 kpa	
	Injection duration (ms)		2.0~3.0 ms	
	Ign. Advance (°)		3~ 17BTDC	
	Ign.Dwell duration (ms)		1.9~ 2.6ms	Battery Volt (V) 14V3.6~4.2ms, 12V4.09~4.66ms
	Air Temp.( °C)		environ.temp ±2 °C	
	Engine Temp. ( °C)		>105 °C	
	O2 sensor voltage (V)(Front)		0~1V	
	O <sup>2</sup> sensor heater(Front)		ON	
	O <sup>2</sup> sensor correct(Front)		-14%~+10%	
	O2 sensor voltage (V)(Rear)		0~1V	
	O <sup>2</sup> sensor heater(Rear)		ON	
	O <sup>2</sup> sensor correct(Rear)		-14%~+10%	
	ISC AngDurMech (°)		20% <ISC < 45%	>45% The scooter with exchange engine oil and clean throttlly body >50% The scooter must clean throttlly body

**6. ENGINE REMOVAL/INSTALLATION**

---

---

---

---

---

---

---

---

---

---

---

**6**

**ENGINE REMOVAL/INSTALLATION**

---

SERVICE INFORMATION ..... 6-2  
ENGINE REMOVAL..... 6-3  
ENGINE INSTALLATION..... 6-6

# 6. ENGINE REMOVAL/INSTALLATION

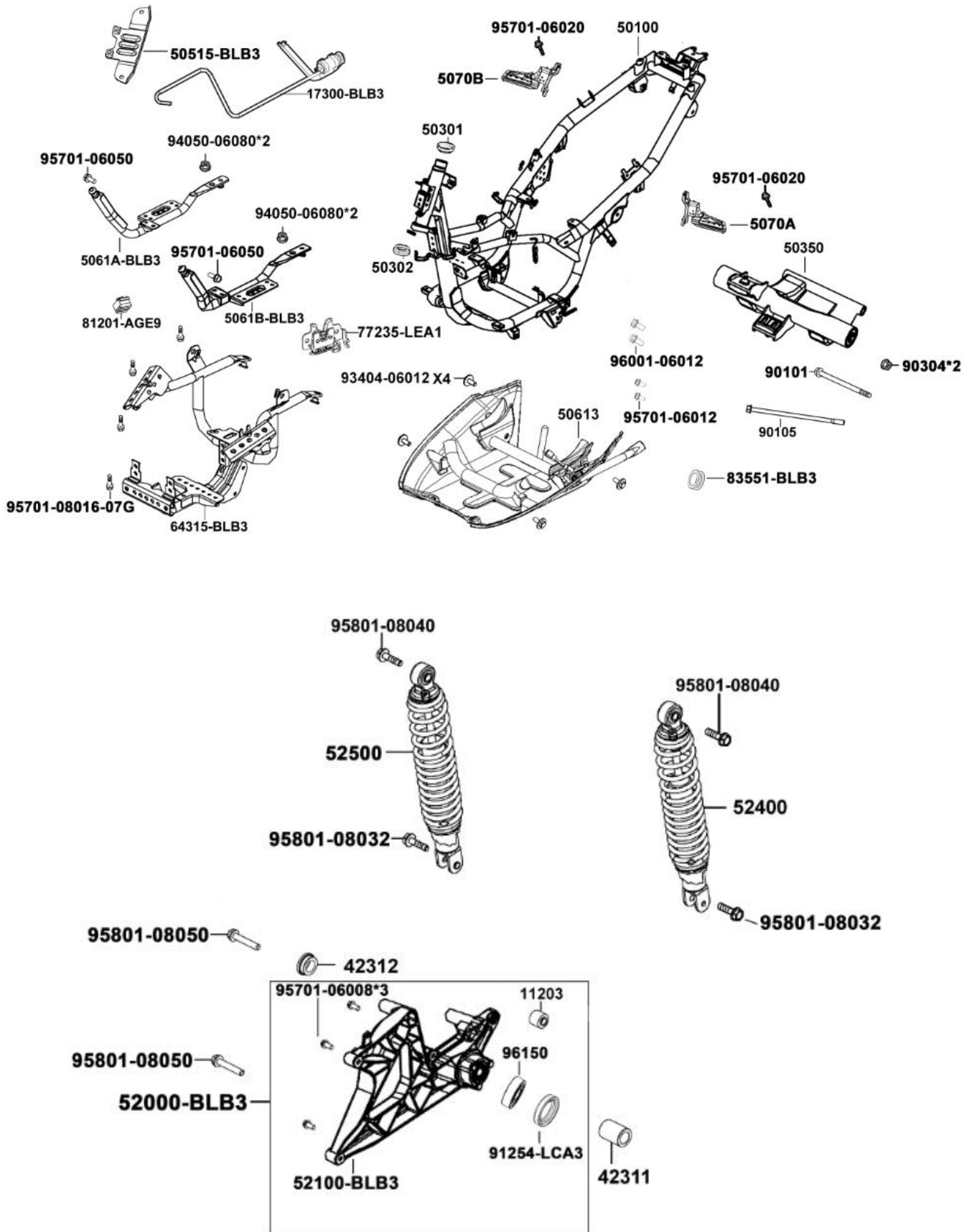

## **6. ENGINE REMOVAL/INSTALLATION**

---

### **SERVICE INFORMATION**

#### **GENERALINSTRUCTIONS**

- A jack or other adjustable support is required to support and maneuver the engine. Be careful not to damage the motorcycle body, cables and wires during engine removal.
- Use towels to protect the motorcycle body during engine removal.
- Before removing the engine, the rear brake caliper must be removed first. Be careful not to bend or twist the brake fluid tube.

### **SPECIFICATIONS**

Engine oil capacity: 0.9 Liter

#### **TORQUE VALUES**

Rear shock absorber upper mount bolt	40 N-m
Rear shock absorber lower mount bolt	40 N-m
Rear axle nut	120 N-n
Engine hanger bolt (frame side)	50 N-m
Engine hanger bolt (ENG. side)	50 N-m
Rear caliper holder bolt	27 N-m
Exhaust muffler pipe nut	20 N-m
Exhaust muffler bracket bolt (attached to RR Fork)	35 N-m
Rear fork bolt (attached to ENG case)	32 N-m



## 6. ENGINE REMOVAL/INSTALLATION

### ENGINE REMOVAL

Remove the frame body cover(2-6).  
 Remove the rear fender (2-11).  
 Disconnect the engine negative cable.  
 Disconnect the starter motor cable from the starter relay.

Engine negative cable



Starter motor cable

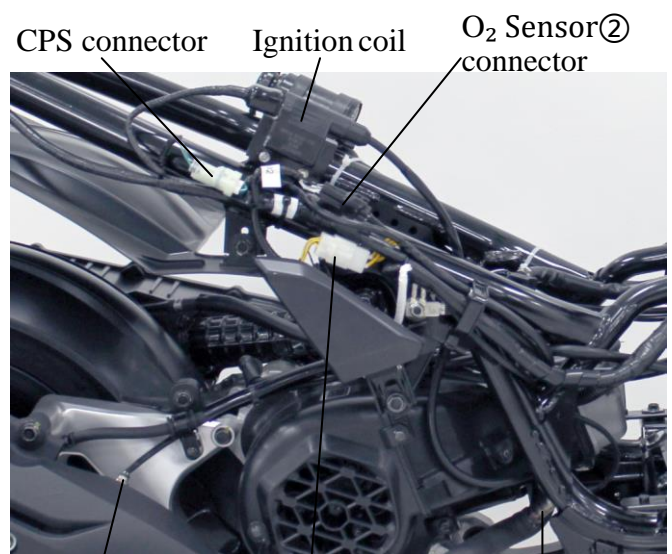

CPS connector

Ignition coil

O<sub>2</sub> Sensor② connector

Disconnect the A.C. Generator wire connector.  
 Remove the spark plug cap.  
 Remove the ignition coil's wire.  
 Remove the O<sub>2</sub> sensor wire.

O<sub>2</sub> Sensor①

A.C.G wire connector

O<sub>2</sub> Sensor②

Disconnect the ECU connector  
 Disconnect the engine temperature sensor connector.  
 Remove the injector's wire.  
 Remove the throttle cable.  
 Remove the vacuum tube.  
 Remove the fuel tube attaching to injector.

ETS

connector

spark plug cap

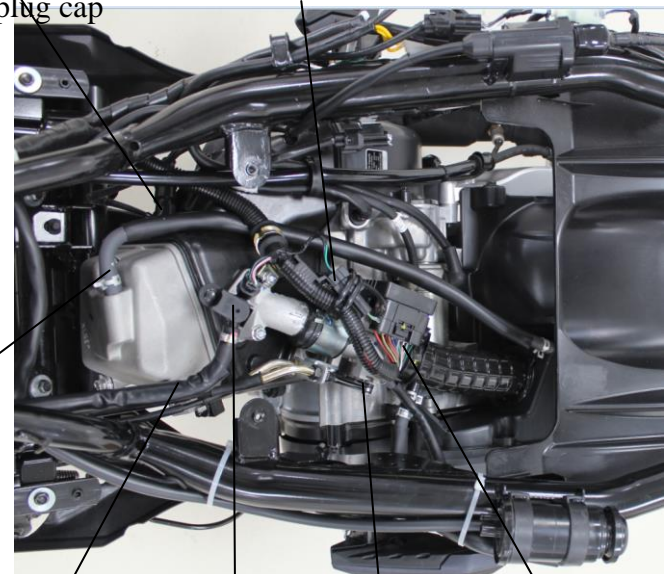

Crankcase Breather Tube

Fuel tube

Fuel injector

Throttle Cable

ECU connector

## 6. ENGINE REMOVAL/INSTALLATION

- Remove the air cleaner assy.
- Remove the exhaust muffler(2-12)



Air cleaner assy



Exhaust muffler

- Remove the rear brake caliper.
- Remove the bolt attaching to rear brake hose clamps.

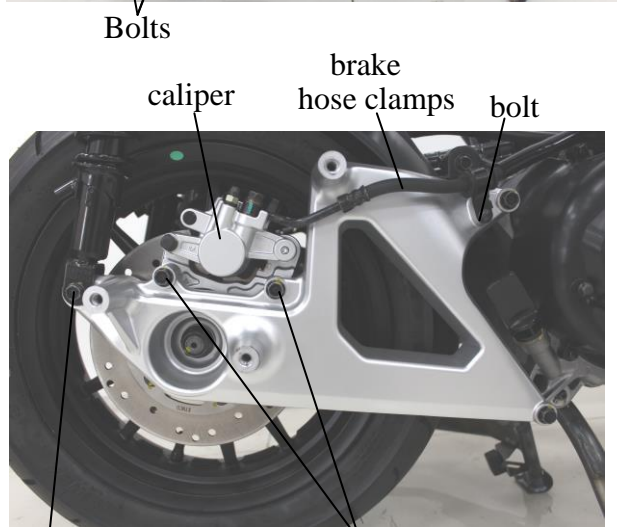

Bolts

caliper

brake hose clamps

bolt

- Remove the rear shock absorbers mounting bolts.



Rear Shock Absorber Bolt

Rear caliper bolts



Rear Shock Absorber Bolt

## 6. ENGINE REMOVAL/INSTALLATION

Remove the engine hanger bolts and pull out the engine with the engine hanger bracket backward.

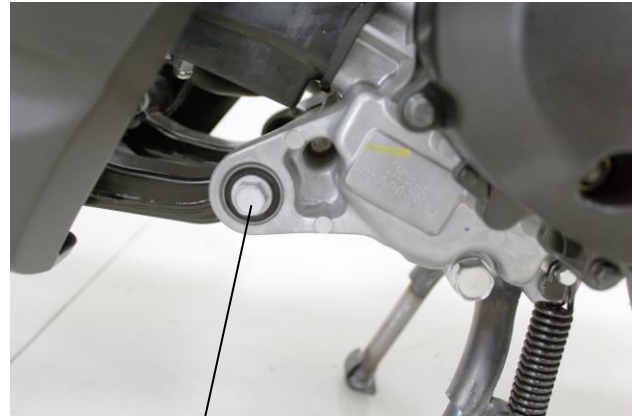

Bolts

Remove the rear flat fork and the rear wheel.



### ENGINE MOUNTING REMOVAL

Remove the engine.

Remove the under cover(2-11).

Remove the engine mounting bolt.

Remove the engine mounting.

Inspect the engine mounting bushings and stopper rubbers for wear or damage.



Bolts

Engine mounting

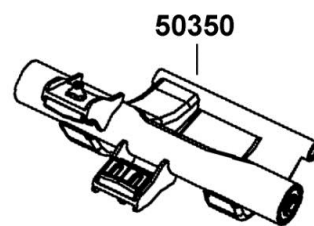

50350

90101

90304\*2

90105



## 6. ENGINE REMOVAL/INSTALLATION

### ENGINE MOUNTING

#### INSTALLATION

Install the engine mounting to the engine.  
Install and tighten the engine mounting bolts.  
Install and tighten the rear flat fork and the rear wheel..

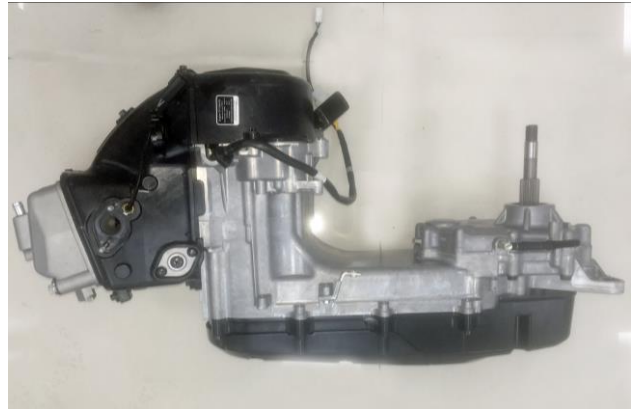

\* At removing the engine, be careful not to catch your hand or finger between the engine hanger and crankcase.

#### ENGINE INSTALLATION

Install the engine and tighten the engine mounting bolts.

**Torque:** 5.0kg-m

Tighten the rear shock absorbers mounting bolts.

**Torque:** Up side 4.0kg-m

Down side 2.5kg-m

Install the removed parts in the reverse order of removal.

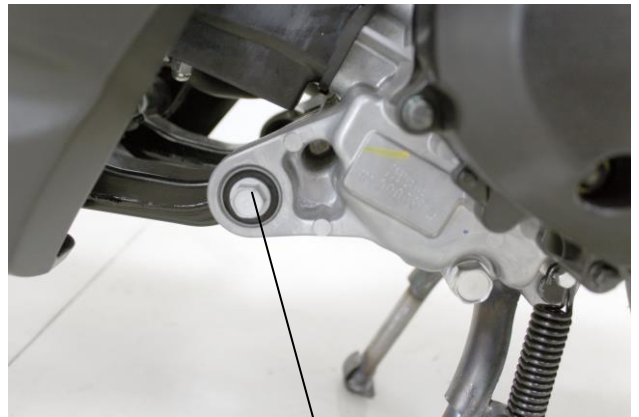

Bolts

\* Tire pressure should be checked when tires are cold.

After installation, inspect and adjust the following:  
Throttle grip free play (3-3)



# 7. CYLINDER HEAD/VALVES CYLINDER / PISTON

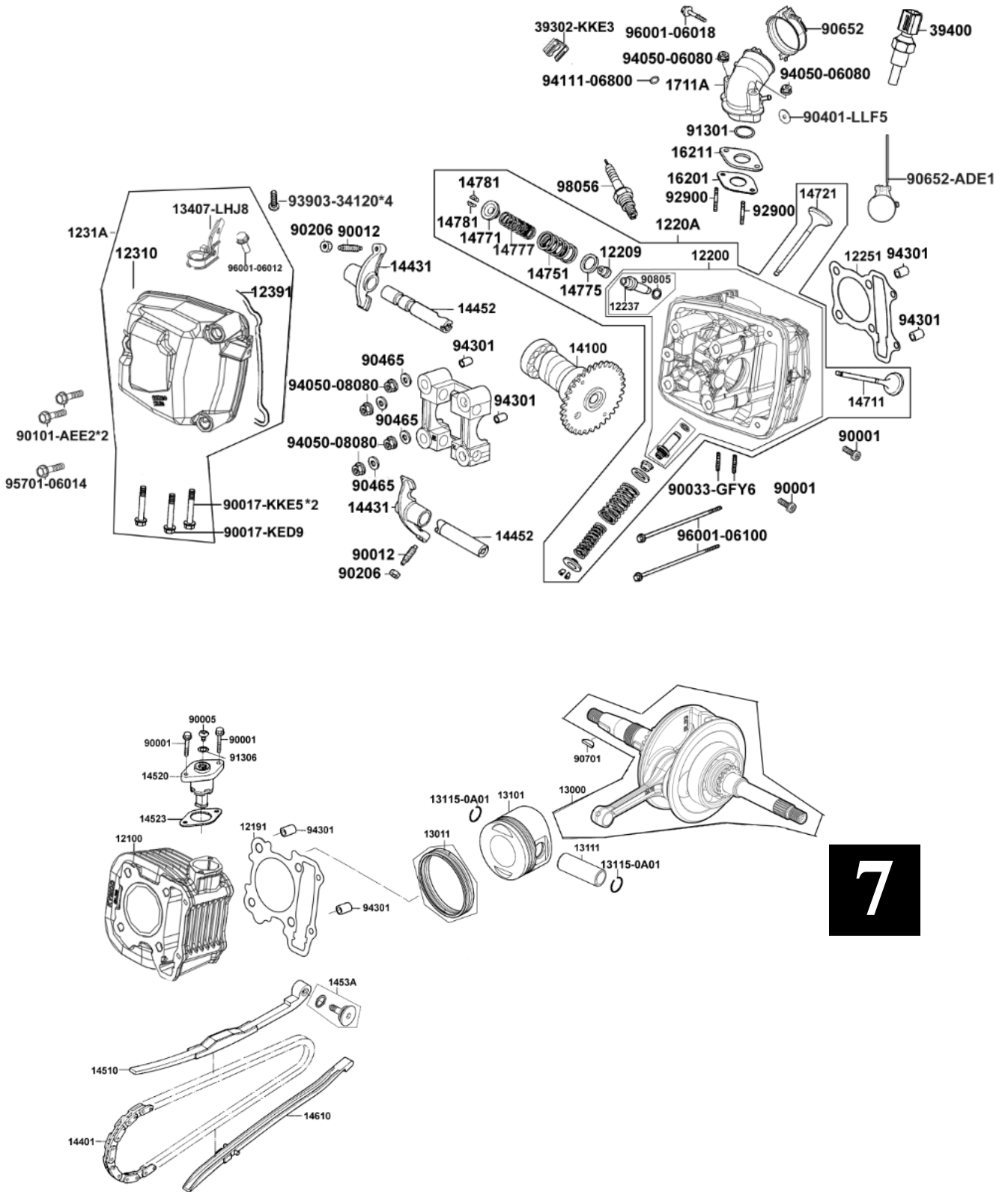

**7**

# 7. CYLINDER HEAD/VALVES CYLINDER / PISTON



Skytown 125

SERVICE INFORMATION.....	7-1	CYLINDER HEAD DISASSEMBLY .....	7-7
TROUBLESHOOTING.....	7-2	CYLINDER HEAD ASSEMBLY .....	7-8
CAMSHAFT REMOVAL.....	7-3	CYLINDER HEAD INSTALLATION.....	7-8
CYLINDER HEAD REMOVAL .....	7-5	CAMSHAFT INSTALLATION .....	7-9

## SERVICE INFORMATION

### GENERAL INSTRUCTIONS

- The cylinder head can be serviced with the engine installed in the frame.
- When assembling, apply molybdenum disulfide grease or engine oil to the valve guide movable parts, valve arm and camshaft sliding surfaces for initial lubrication.
- The camshaft is lubricated by engine oil through the cylinder head engine oil passages. Clean and unclog the oil passages before assembling the cylinder head.
- After disassembly, clean the removed parts and dry them with compressed air before inspection.
- After removal, mark and arrange the removed parts in order. When assembling, install them in the reverse order of removal.

### SPECIFICATIONS

Item		Standard (mm)	Service Limit (mm)
Valve clearance (cold)	IN	0.10	—
	EX	0.10	—
Cylinder head compression pressure		15kg/cm <sup>2</sup>	

Item		Standard (mm)	
Cylinder	I.D.	52.40~52.41	
	Warpage	0.01	
	Cylindricity	0.01	
	True roundness	0.03	
Piston, piston ring	Ring-to-groove clearance	Top	0.015~0.055
		Second	0.015~0.055
	Ring end gap	Top	0.10~0.25
		Second	0.30~0.50
		Oil side rail	0.2~0.7
	Piston O.D.		52.37~52.39
	Piston O.D. measuring position		9mm from bottom of skirt
	Piston-to-cylinder clearance		0.010~0.040
Piston pin hole I.D.		13.002~13.008	
Piston pin O.D		12.994~14.000	
Piston-to-piston pin clearance		0.002~0.014	
Connecting rod small end I.D. bore		13.016~13.026	



## 7. CYLINDER HEAD/VALVES CYLINDER / PISTON

### TORQUE VALUES

Cylinder head nut	2.0kg-m	Apply engine oil to threads
Valve clearance adjusting nut	0.9kg-m	Apply engine oil to threads
Stud bolt	0.9~1.1kg-m	

### SPECIAL TOOLS

Valve spring compressor	A120E00040
Flywheel puller	A120E00002

### TROUBLESHOOTING

- The poor cylinder head operation can be diagnosed by a compression test or by tracing engine top-end noises.

#### Poor performance at idle speed

- Compression too low

#### Compression too low

- Incorrect valve clearance adjustment
- Burned or bend valves
- Incorrect valve timing
- Broken valve spring
- Poor valve and seat contact
- Leaking cylinder head gasket
- Warped or cracked cylinder head
- Poorly installed spark plug

#### Compression too high

- Excessive carbon build-up in combustion chamber

#### White smoke from exhaust muffler

- Worn valve stem or valve guide
- Damaged valve stem seal

#### Abnormal noise

- Incorrect valve clearance adjustment
- Sticking valve or broken valve spring
- Damaged or worn camshaft
- Worn cam chain guide
- Worn camshaft and rocker arm

## 7. CYLINDER HEAD/VALVES CYLINDER / PISTON

### 7.1 CYLINDER HEAD COVER REMOVAL

Remove 7 bolts  
Remove the cover.

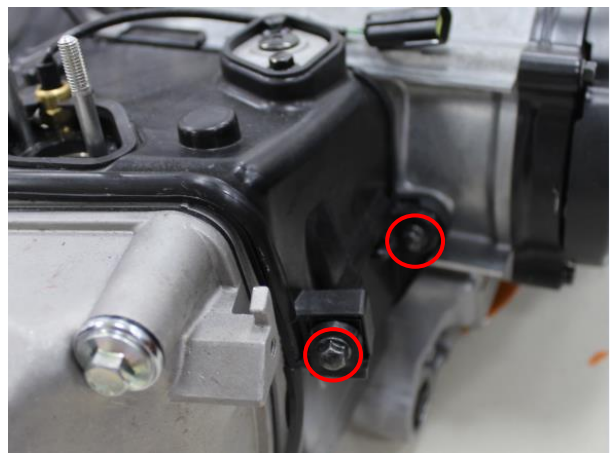
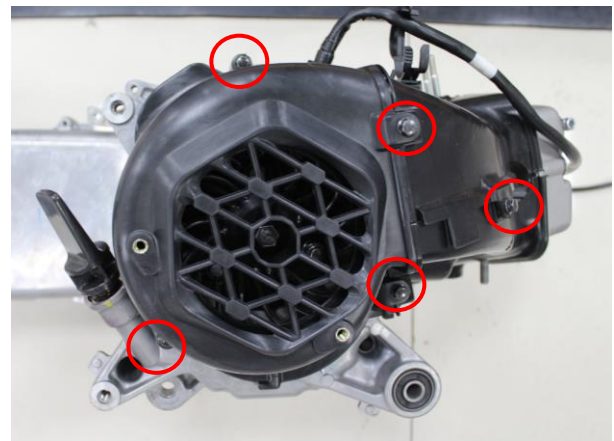

Remove 3 bolts and remove the cylinder head cover and gasket. Replace it with a new one when installation.



## 7. CYLINDER HEAD/VALVES CYLINDER / PISTON

### 7.2 CAMSHAFT/ROCKER ARM REMOVAL

Safety first: Protective gloves and eyewear are recommended at this point.

Remove the spark plug, see the spark plug chapter.

Remove the cylinder head cover, see the cylinder head cover chapter.



The cam chain tensioner is located on top of the cylinder.



Remove the cam chain tensioner cap bolt with a 10mm socket.



Remove the cam chain tensioner out of the cylinder.



## 7. CYLINDER HEAD/VALVES CYLINDER / PISTON

---

Remove the camshaft sprocket bolt.

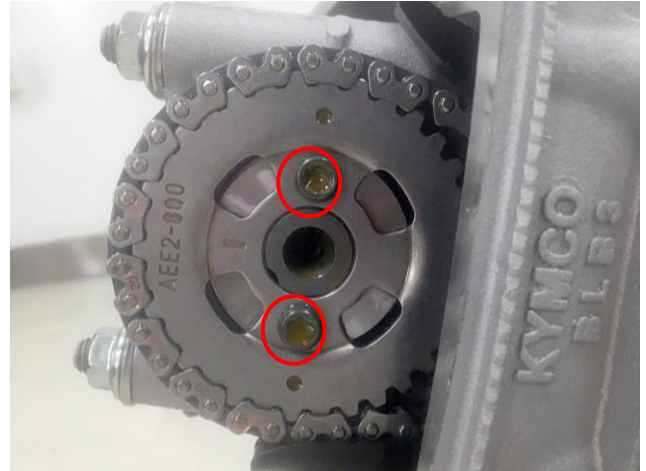

Remove the camshaft sprocket as shown,  
Support the chain so it does not fall into the  
cylinder head.

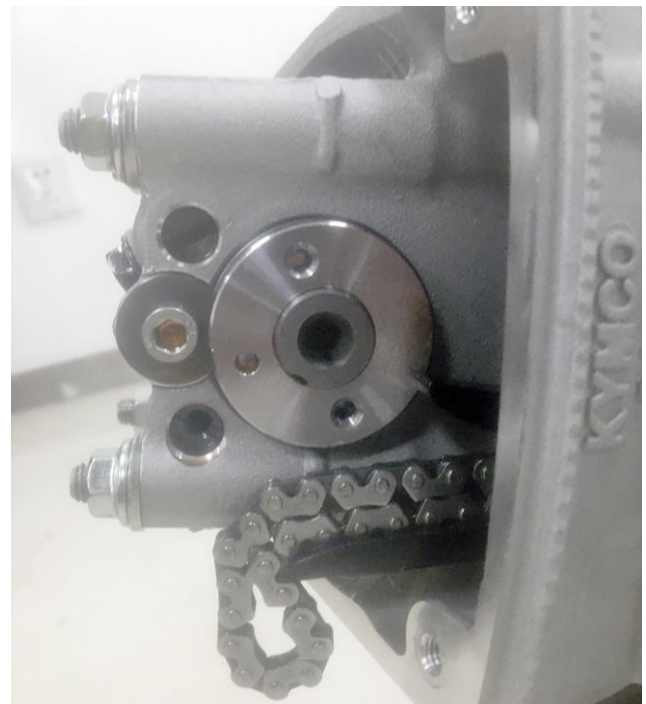

## 7. CYLINDER HEAD/VALVES CYLINDER / PISTON

Remove the set plate bolt.  
Remove the set plate.

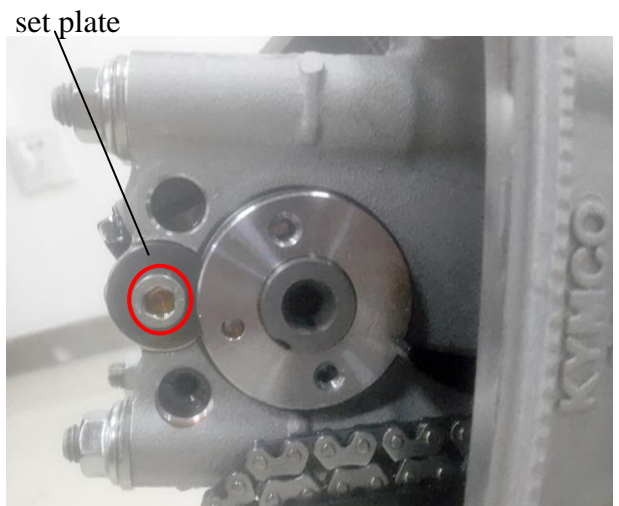

Remove the camshaft from the cylinder head.



Remove the 2 rocker arm shafts bolts.

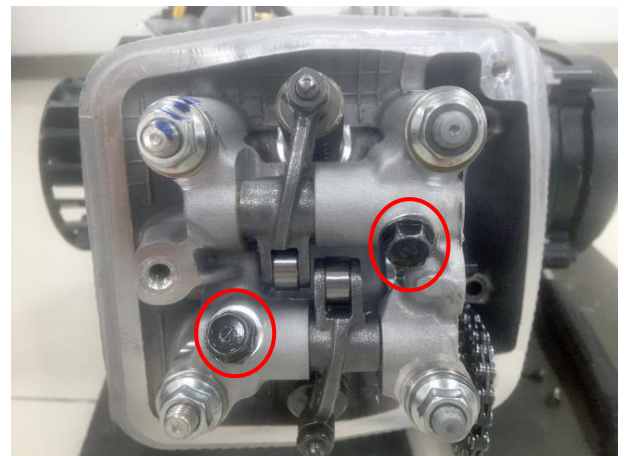

Lift the rocker arms as the shafts are removed.





## 7. CYLINDER HEAD/VALVES CYLINDER / PISTON

### 7.3 INSPECTION

Inspect the camshaft cam heights for the intake and exhaust lobes.

Inspect the camshaft bearings for excessive play or roughness.

Replace the entire camshaft assembly if the bearings are rough or have excessive play.

Item		Standard(mm)
Camshaft cam height	IN	32.22±0.08
	EX	31.76±0.08

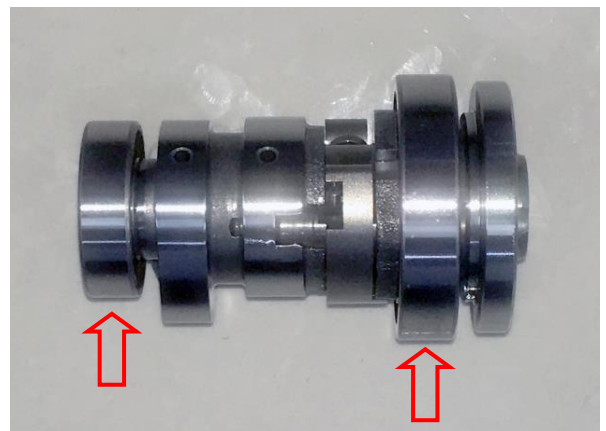
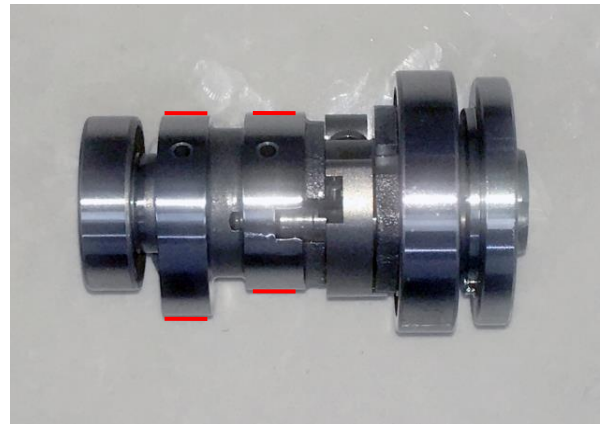

Inspect the rocker arm shaft outer diameter for the intake and exhaust valves.

Item		Standard(mm)
Valve rocker arm shaft O.D	IN	9.972-9.987
	EX	9.972-9.987



Inspect the rocker arm shaft inner diameter for the intake and exhaust valves.

Item		Standard(mm)
Valve rocker arm I.D	IN	10.00-10.015
	EX	10.00-10.015

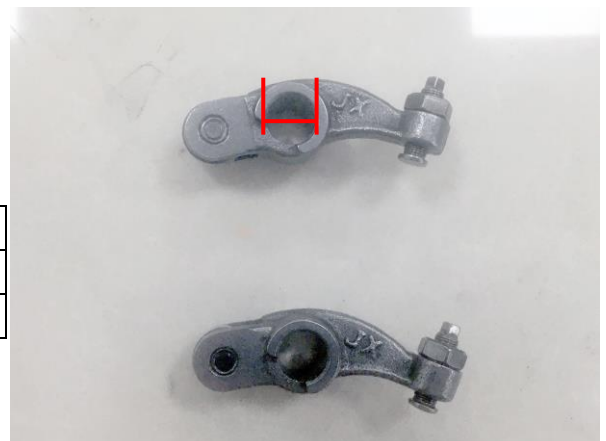



## 7. CYLINDER HEAD/VALVES CYLINDER / PISTON

### 7.4 INSTALLATION

The crankshaft must be rotated clockwise until the piston is at top dead center on the compression stroke



Turn the A.C. generator flywheel clockwise to the top dead center (TDC) on the compression stroke so that the “T” mark on the flywheel aligns with the index mark on the right crankcase cover.



Lubricate the camshaft lobes and bearings with fresh engine oil.  
Insert the camshaft into the camshaft holders with the lobes facing down.



Lubricate the inside diameters of the rocker arms and the roller with fresh engine oil.  
Wipe the rocker arm shafts clean. Insert the rocker arm shafts into the camshaft holders and rocker arms.



## 7. CYLINDER HEAD/VALVES CYLINDER / PISTON

Install the 2 rocker arm shafts bolts.  
Apply engine oil to the threads of the rocker arm shafts bolts. tighten in crisscross pattern over the course 2-3 rounds of tightening to reach specific torque.



Install the set plate so it fit into the groove on the camshaft and between the projections on the rocker arm shafts.  
Apply a small amount of blue Loctite (non-permanent) to the threads of the set plate bolt.  
Thread in the bolt and tighten it to specification with a 5 mm Allen socket.

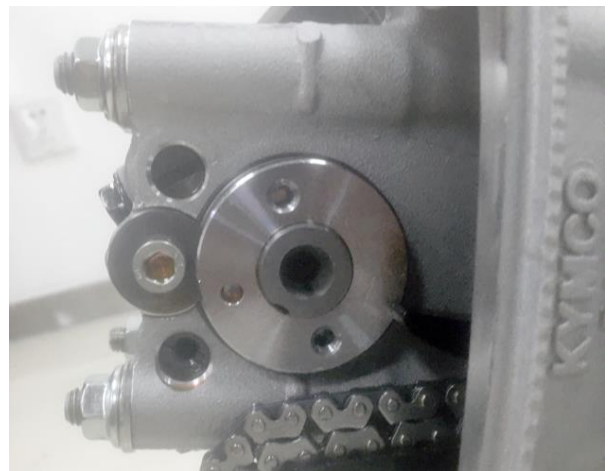

Install the camshaft sprocket onto the camshaft so the camshaft sprocket boss fits into the appropriate hole on the camshaft sprocket.  
Make sure the camshaft sprocket boss is facing up so it is visible above the edge of the cylinder head as shown.  
Align the horizontal marks on the camshaft sprocket with the top edge of the cylinder head as shown. Fit the cam chain over the camshaft sprocket



## 7. CYLINDER HEAD/VALVES CYLINDER / PISTON

For correct engine timing, the marks on the camshaft sprocket must be even with cylinder head mating surface. At the same time, the “T” mark is lined up with the mark on the right crankcase cover. The camshaft lobes should be facing down and there should be slack in the rocker arms.



Apply a small amount of Loctite to threads of the camshaft sprocket bolts. Thread in the bolts and tighten to specification.

Item	Qty	Thread size (mm)	Torque	
			kgf-m	N-m
Cam sprocket bolt	2	6	1.0~1.4	10~14



### **Double check the engine timing**

Use a small flat blade screwdriver bringing in the cam chain tensioner rod. Turn the screwdriver counter clockwise to retract the rod. The rod must be held in with the screwdriver until the cam chain tensioner has been installed.





## 7. CYLINDER HEAD/VALVES CYLINDER / PISTON

Install the cam chain tensioner with a new gasket. Insert the mounting bolts and tighten them evenly to specification with an 8mm socket. Release the cam chain tensioner rod.

Item	Qty	Thread size (mm)	Torque	
			kgf-m	N-m
Cam chain tensioner bolt	2	6	0.8~1.2	7.8~11.8

O-Ring



**Rotate the crankshaft 360° clockwise and check the engine timing one more time.**

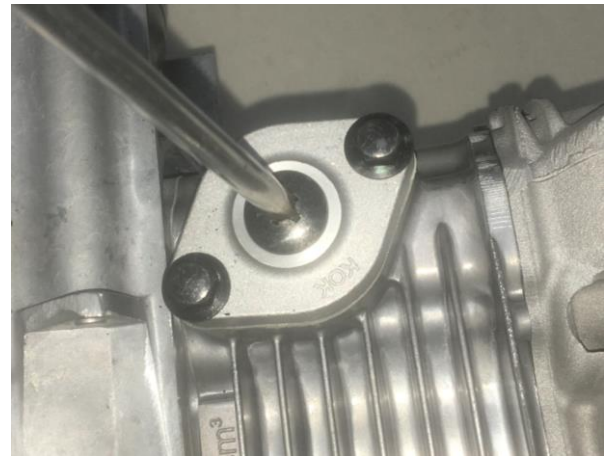

Make sure the cam tensioner cap bolt O-ring is in good condition and install the cam chain tensioner cap bolt. Tighten the bolt securely.



Install the fan cover and install the 7 bolts.



# 7. CYLINDER HEAD/VALVES CYLINDER / PISTON

## 7.5 CYLINDER HEAD

Remove the spark plug ,see the spark plug chapter.

Remove the cylinder head cover, see the cylinder head cover.

Remove the camshaft sprocket, see the camshaft chapter.

Remove the 4 Nuts and the 2 bolts.

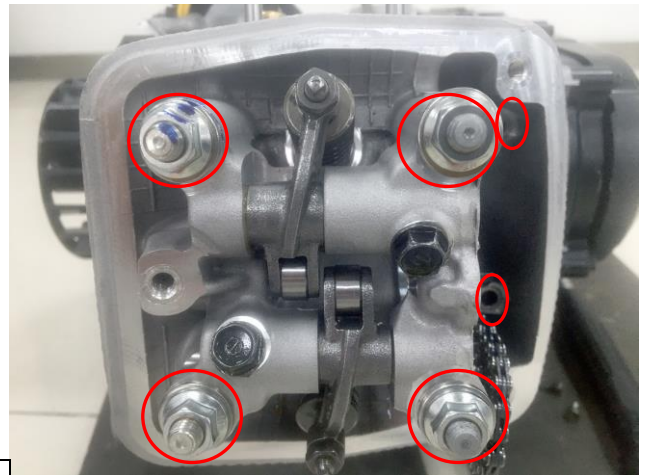

Item	Qty	Thread size (mm)	Torque	
			kgf-m	N-m
Cylinder head stud nut	4	8	1.8~2.2	18~22

Item	Qty	Thread size (mm)	Torque	
			kgf-m	N-m
Cylinder head Bolt Flange	2	6	1.0-1.4	10~14

Lift the cylinder head off the stud, guide the cam chain through the opening in the cylinder head , but don't allow the cam chain to fall into the crankcase.



Remove the cylinder head gasket.



## 7. CYLINDER HEAD/VALVES CYLINDER / PISTON

---

Remove the 2 dowel pins from the left side of the cylinder head studs.



Remove the intake plate and gasket from the cylinder head.

remove the engine temperature sensor if needed.



Clean the combustion chamber with a contact cleaner, a plastic knife, brush .  
Take care only to remove carbon and not scrape the head.





## 7. CYLINDER HEAD/VALVES CYLINDER / PISTON

To remove valves, see the valve chapter.  
Place a straight edge across the bottom of the cylinder head and check for warp with a feeler gauge. You will need to check clearance readings from several places on the bottom of the cylinder head surface for warp.

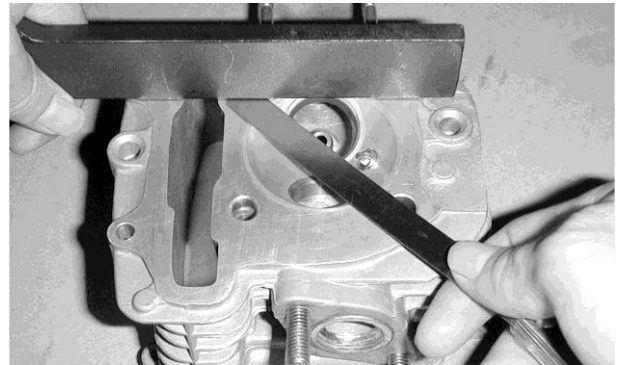

### 7.6 VALVES

**SAFETY FIRST:** Protective gloves and eyewear are recommended at this point.

#### Removal

Remove the camshaft, see the camshaft chapter

Remove the cylinder head, see the cylinder head chapter

Record the position of all parts so they can be returned to their proper place during reassembly.

Push down the valve springs with a valve spring compressor.

Remove the split keepers, there are two per valve



Special Tool: valve spring compressor, E040



## 7. CYLINDER HEAD/VALVES CYLINDER / PISTON

Remove the spring retainer.

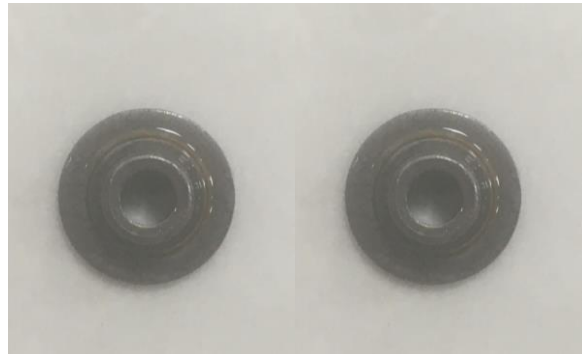

Remove the valve springs.



Push the valve stem down and remove the valve from the combustion chamber side of the cylinder head. Rotate the valve as it is removed

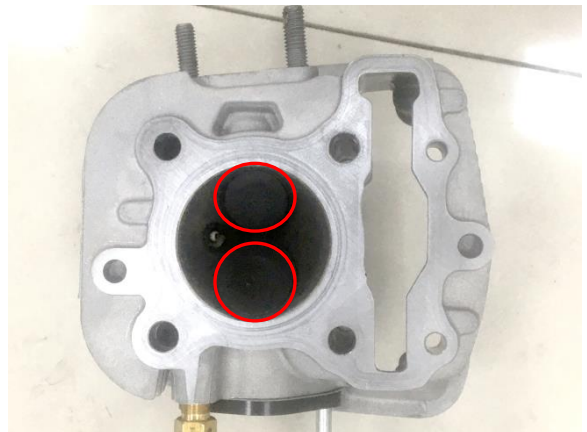

Remove the valve seal from the valve guide. The valve seal should be replaced if they are removed or you need to install new valves.

Remove the spring seat.

Install in reverse order of removal.



## 7. CYLINDER HEAD/VALVES CYLINDER / PISTON

### 7.7 INSPECTION

Inspect the spring for fatigue and damage.  
Replace the springs if needed.



Inspect the valve for burning and damage.  
Measure the stem diameter in several places  
where the valve contact the guide, if the  
measurement is below specification, replace  
the valve.

Item		Standard(mm)
Valve stem O.D	IN	4.475~4.49
	EX	4.455~4.47



## 7. CYLINDER HEAD/VALVES CYLINDER / PISTON

Inspect the valve seat and the valve seat width.  
The valve seat should be centered on the valve face. If the seat is pitted, worn out, or fits poorly on the valve face, the valve seat must be resurfaced.

Item		Standard(mm)
Valve seat width	IN	1.2
	EX	1.2



Measure the inside diameter of the valve guides.  
Replace the guides if the measurement is beyond specification.

Calculate the valve stem-to-guide clearance.  
Replace the guide and valve if the clearance is beyond specification.

Item		Standard(mm)
Valve guide I.D	IN	4.5-4.512
	EX	4.5-4.512
Valve stem-to-guide Clearance	IN	0.01-0.037
	EX	0.03-0.057





## 7. CYLINDER HEAD/VALVES CYLINDER / PISTON

### 7.8 Cam Chain Guide

Slide out the lower cam chain guide. Inspect the guide for excessive wear and damage. Replace the guide as needed.



To remove the upper chain guide, remove the CVT, see the CVT chapter.

Remove the bolt with an 8mm Allen wrench.



Remove the upper chain guide.



## 7. CYLINDER HEAD/VALVES CYLINDER / PISTON

### 7.9 Cylinder and Piston

**SAFETY FIRST:** Protective gloves and eyewear are recommended at this point.

#### Cylinder Block Removal

Remove the engine from the frame, see the engine removal chapter.

Remove the cylinder head cover, see the cylinder head cover chapter.

Remove the camshaft sprocket, see the Camshaft chapter.

Remove the cylinder head, see the cylinder head chapter.

Remove the lower cam chain guide, see the cam chain guide chapter.

Slide the cylinder off the studs and piston.

Guide the cam chain through its opening and don't allow it to fall into the crankcase

Remove the cylinder.

Remove the gasket.

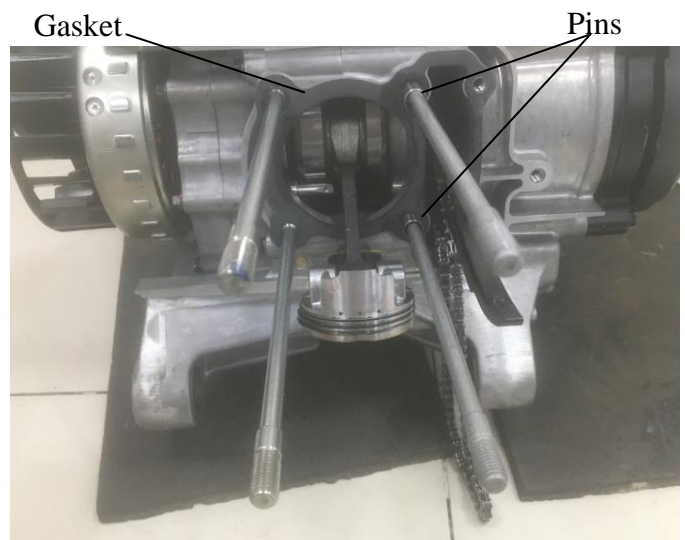

Remove the 2 cylinder dowel pins from the left side of the studs



## 7. CYLINDER HEAD/VALVES CYLINDER / PISTON

Remove the piston pin clips with a pick or  
needle nose pliers.

Discard the piston pin clips



clip

Remove the piston pin and the piston.  
Clean off the cylinder mating surface, but take  
care to keep debris from falling into the  
crankcase.



Piston Pin

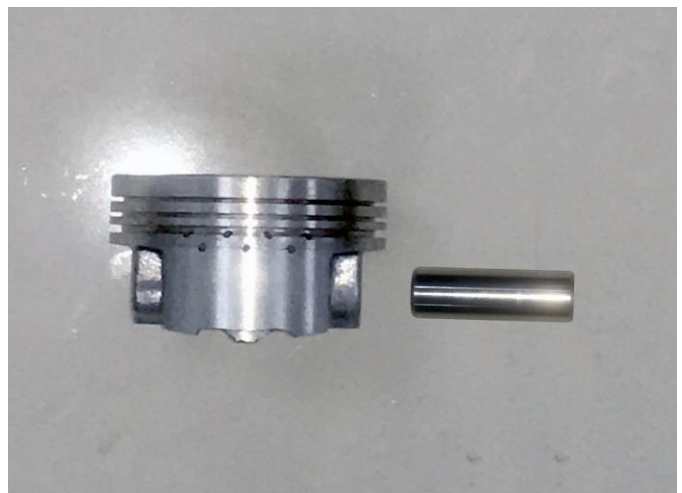

## 7. CYLINDER HEAD/VALVES CYLINDER / PISTON

Spread the piston rings and lift them off opposite the gap. Spread the rings the minimum amount during removal. The rings can be easily damaged.

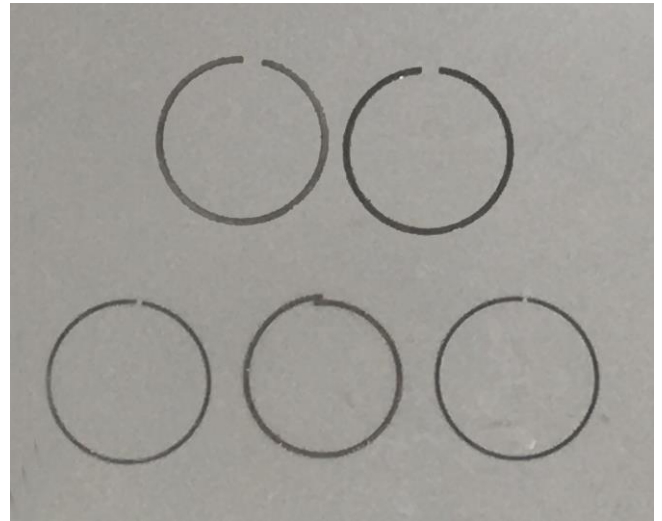

The two upper rings are each a single piece of metal. The oil ring consists of an expander ring and two side rails.

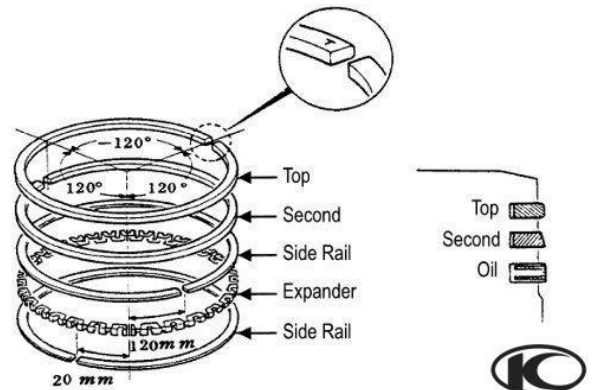

Clean off the carbon build up of the piston with a stiff bristled plastic brush or rag. Never use a wire brush to clean a piston.



Also clean out the ring grooves. You can use an old ring to scrape.



# 7. CYLINDER HEAD/VALVES CYLINDER / PISTON

## 7.10 INSPECTION

The cylinder and piston must be replaced as a set.

Inspect the cylinder bore for damage and abnormal wear.

Measure the cylinder diameter as below with a telescoping gauge.

Inspect the cylinder front to back and side to side at three different height levels with a dial bore gauge. Replace the cylinder and piston as a set if the cylinder is out of specification.

Calculate the cylinder taper. The taper is the maximum difference between either yellow and brown or blue and green.

Calculate the cylinder out of round. The out of round is greatest out of yellow, purple, or brown minus the smallest of blue, red or green.

Measure the outer diameter of the piston at 8mm up from the bottom of the skirt at a 90° to the piston pin. Measure the piston with vernier caliper or a micrometer. Check the piston for wear, damage, and extreme discoloration.

Item	Standard mm
Piston-to-cylinder clearance.	-0.010~+0.040

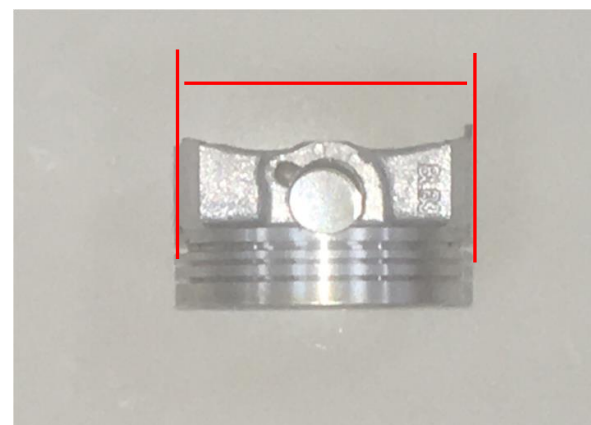
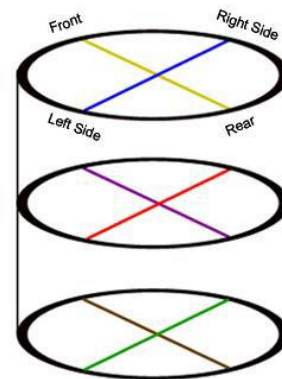

## 7. CYLINDER HEAD/VALVES CYLINDER / PISTON

Measure the piston pin diameter with a micrometer. Measure the piston pin bore diameter with vernier calipers or a small bore Gauge. Measure at 3 different points for each. Replace the parts if any of the specifications are not met.

Item	Standard mm
Piston pin O.D.	12.994~13.000
Piston pin hole I.D.	13.002~13.008
Piston-to-piston pin clearance	0.002~0.014



Measure the inner diameter of the small end of the connecting rod with vernier calipers.

Item	Standard mm
Connecting rod small end I.D.Bore	13.016-13.026

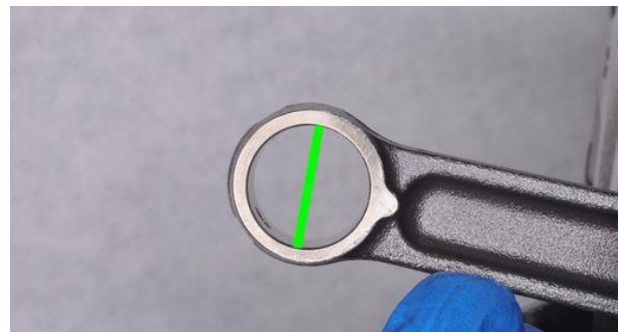

Measure the ring groove width and the ring-to-groove clearance with feeler gauge.

Item		Standard mm
Ring-to-groove clearance	1st	0.02-0.055
	2nd	0.02-0.055





# 7. CYLINDER HEAD/VALVES CYLINDER / PISTON

Insert the top ring into the cylinder. Push the top Ring in the cylinder about an inch. Use the piston to push in the ring to keep it square with the cylinder.

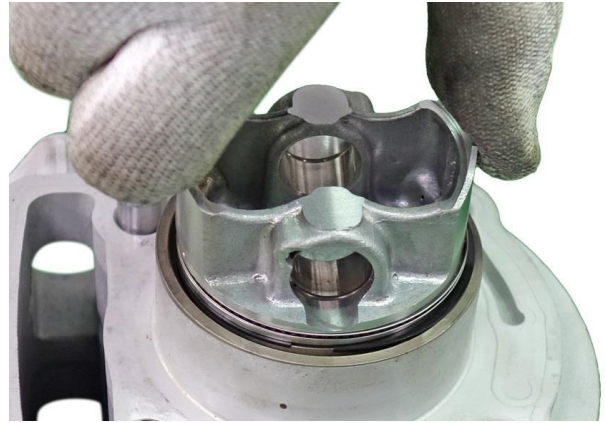

Measure the ring gap with a feeler gauge. Repeat this procedure with second ring and the oil side Rails.

Item		Standard mm
Ring end gap	Top	0.10-0.25
	Second	0.30-0.50
	Oil side rail	0.2-0.7

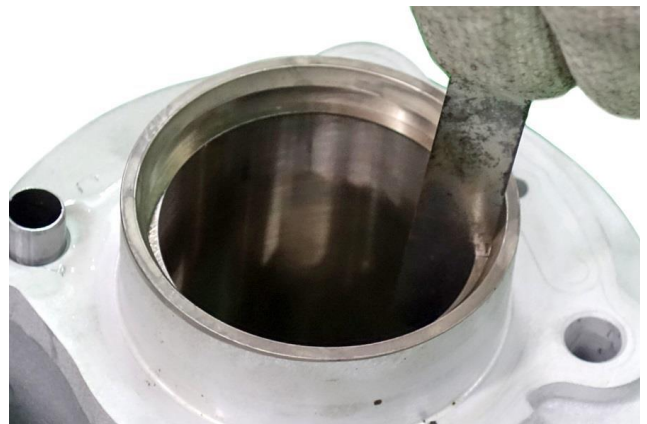

## Assembly

Clean the piston ring grooves and apply fresh engine oil to the piston rings. Spread the rings the minimum amount possible to install them. Do not try and force them on the piston.



Install the top and second rings with their markings facing up. Install the rings to the piston as shown above so that no ring end gaps line up with the piston pin or perpendicular to the piston pin. The rings should turn easily on the piston without sticking or roughness.

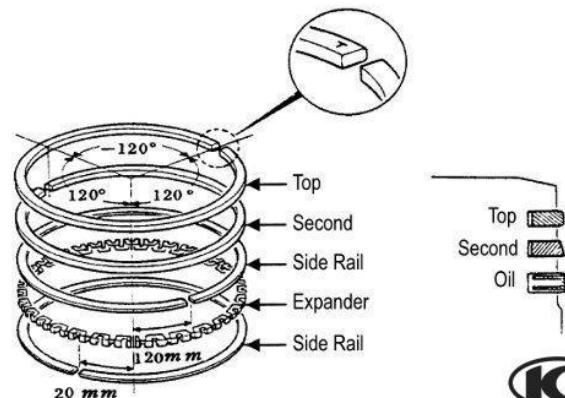

## 7. CYLINDER HEAD/VALVES CYLINDER / PISTON

---

Install the oil expander ring so that the ends are not overlapping. Install the steel rails above and below the oil ring.

Lubricate the piston pin and the small end of the connecting rod with fresh engine oil.

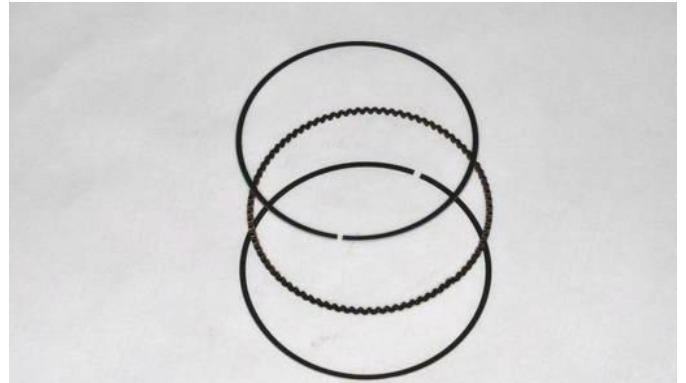

The “O” mark should face the intake side of the engine.



Place the piston over the connecting rod.  
Insert the piston pin into the piston and rod.





## 7. CYLINDER HEAD/VALVES CYLINDER / PISTON

Install a new piston pin clips securely into the grooves. Turn the gap in the clips away from the access gap.



Make sure the cylinder head mating surface is clean. Install the two dowel pins as shown. Install a new base gasket onto the crankcase.



Coat the inside of cylinder, piston rings, and piston with fresh engine oil. Lower the cylinder over the studs and guide the piston into the cylinder while you are compressing the rings with your fingers.

Be careful not to damage the rings during this step. Bring the cam chain and guide through the opening.



Insert the lower cam chain guide and make sure it is seated correctly.

Install the cylinder head, see the cylinder head chapter.

Install the camshaft, see the camshaft chapter

Install the cylinder head cover, see the cylinder head cover chapter.

Install the engine into the frame, see the engine Installation chapter.

## 7. CYLINDER HEAD/VALVES CYLINDER / PISTON

### 7.11 A.C. Generator and Starter Clutch

**SAFETY FIRST:** Protective gloves and eyewear are recommended at this point.

#### Removal

Drain the engine oil and remove the oil filter.

See the engine oil chapter.

Remove the 7 cover bolts with an 8mm socket

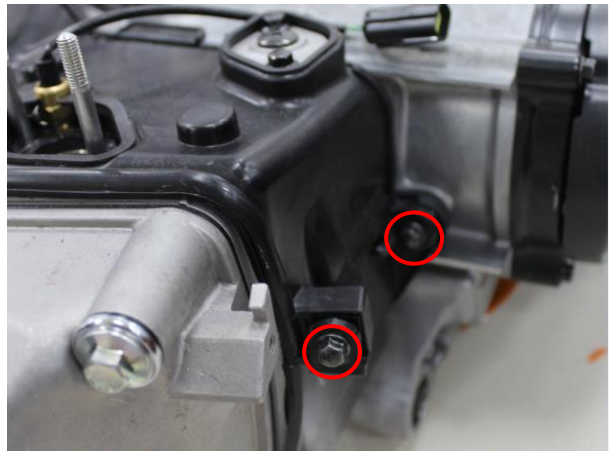
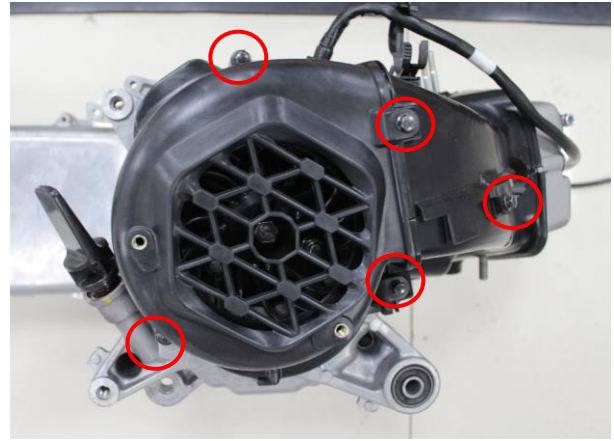

Remove the 3 bolts, and remove the fan.

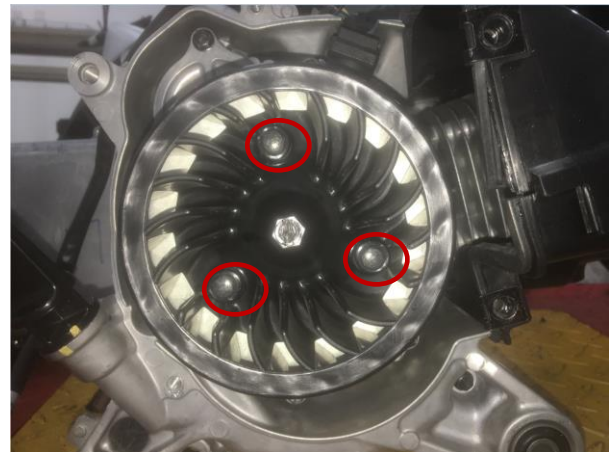

Remove the 17mm nut and washer.



## 7. CYLINDER HEAD/VALVES CYLINDER / PISTON

Item	Tool No
Flywheel puller	A120E00002

Apply grease to the threads of the flywheel puller tool before using it. Thread the puller onto the flywheel. Hold the tool with a large wrench and turn in the bolt until the pressure separates the flywheel from the crankshaft.



Remove the flywheel from the crankshaft.





## 7. CYLINDER HEAD/VALVES CYLINDER / PISTON

### Stator and Pulsar Coil/ Crank Position Sensor

To inspect the stator, see the charging system chapter.

For crank position sensor inspection, see the Ignition system chapter

Free the rubber wire grommet from the right crankcase cover

Remove the 3 stator mounting bolts and the 2 crank position sensor bolts with an 8mm socket  
Remove the stator and the crank position sensor together.

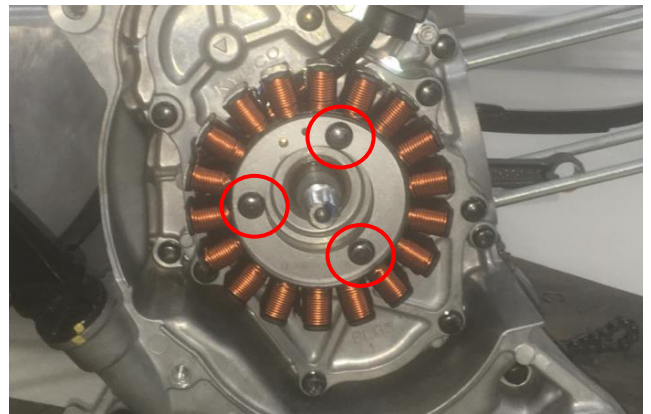
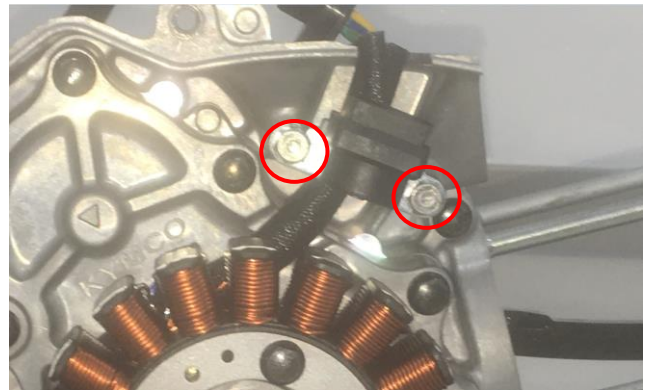
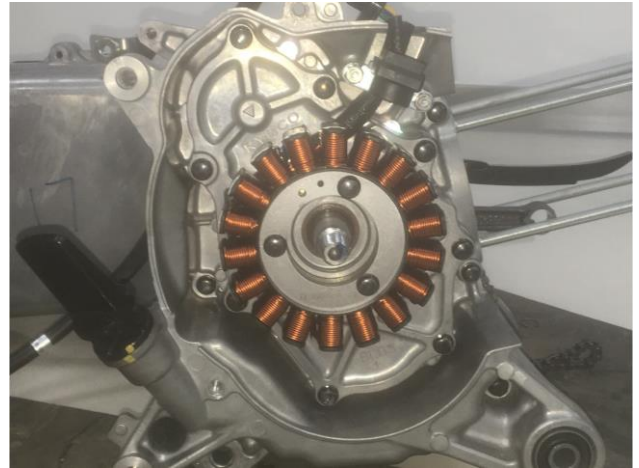

## 7. CYLINDER HEAD/VALVES CYLINDER / PISTON

### Starter Clutch

Remove the 8 bolts, and remove the starter clutch cover.

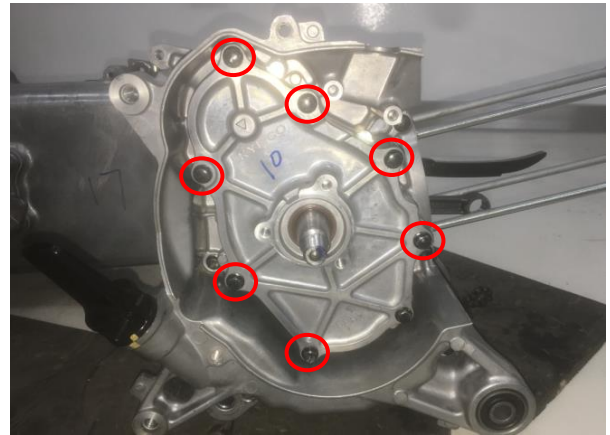

Remove the starter idle gear and shaft from the crankcase.

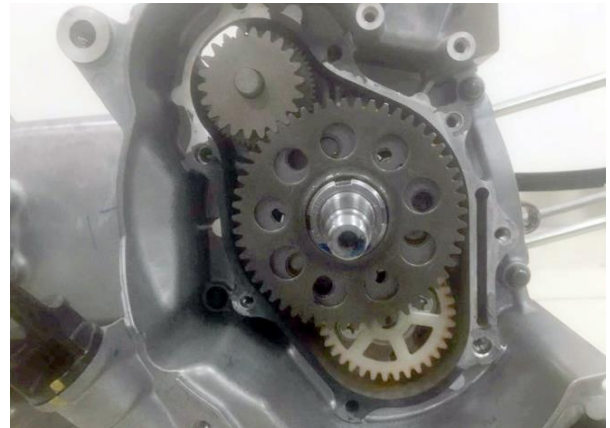

Use the special tool to remove the nut.  
Special tool: A120E00010

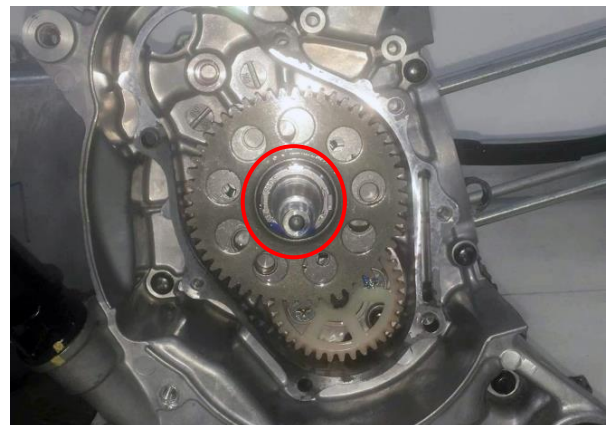

Remove the nut and washer, and then remove the starter clutch gear.





## 7. CYLINDER HEAD/VALVES CYLINDER / PISTON

---

Remove the starter clutch

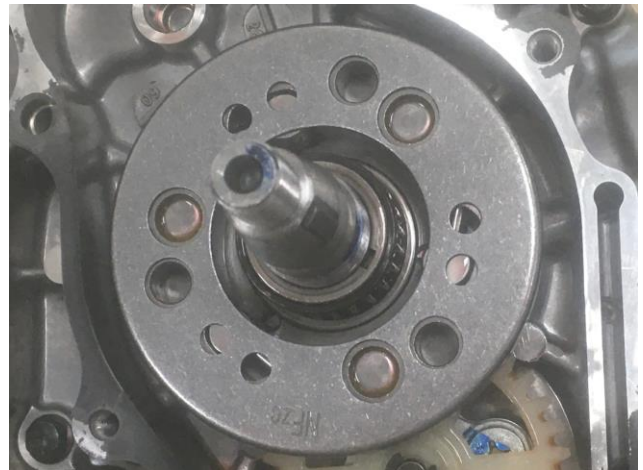

Take the bearing out of the starter clutch.



### **Inspect**

Inspect the starter idle gear and shaft for wear and damage.

Replace the idle gear and shaft if needed.



## 7. CYLINDER HEAD/VALVES CYLINDER / PISTON

Inspect the starter driven gear for wear and damage. Measure the inside and outside diameter of the starter driven gear and replace if needed.

Item	Standard mm
Starter drive gear I.D	38(-0.035~-0.080)
Starter drive gear O.D	95.6(-0.2~0)



Fit the boss of the starter driven gear into the starter clutch. The Starter clutch should only allow the driven gear to turn in one direction. If the starter clutch allows turning both ways or will not let the driven gear rotate smoothly in one direction, the starter clutch must be replaced.



## 7. CYLINDER HEAD/VALVES CYLINDER / PISTON

---

### Installation

Put the bearing on the starter clutch.



Install the starter clutch

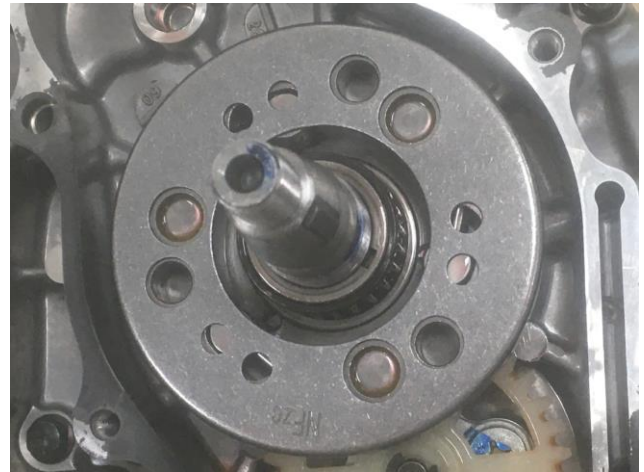

Install the starter clutch gear



## 7. CYLINDER HEAD/VALVES CYLINDER / PISTON

Put on the washer and nut, then tighten the nut.

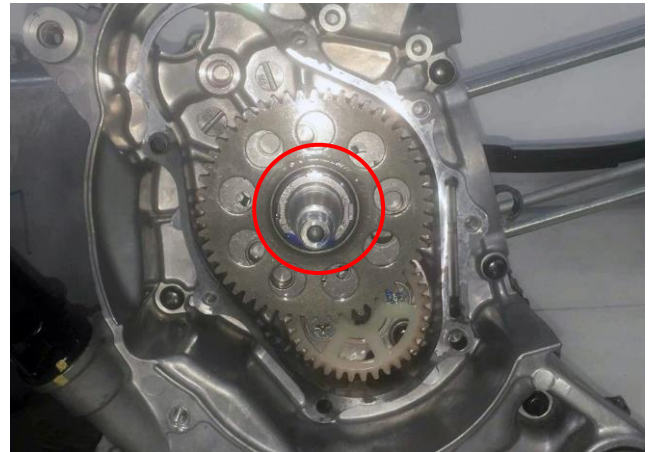

Lubricate the starter idle gear shaft with fresh engine oil. Install the starter idle gear and shaft into the crankcase.

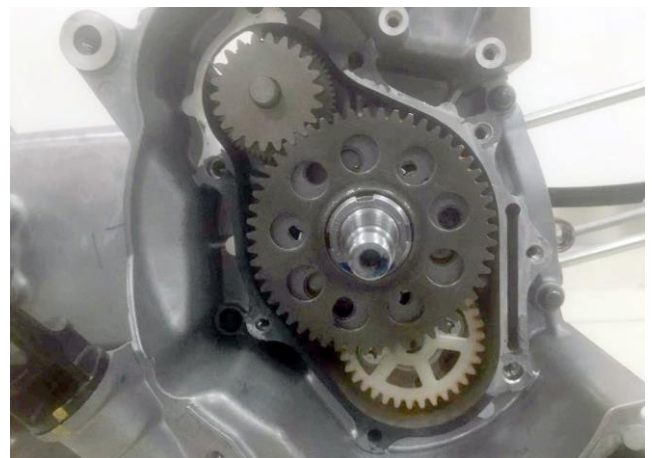

Install the starter clutch cover, and then tighten the 8 bolts.



### Stator and Crank Position Sensor

Fit the stator and the CPS into the generator cover together as shown.





## 7. CYLINDER HEAD/VALVES CYLINDER / PISTON

---

Coat the rubber grommet in silicone sealant where it contacts the generator cover. Fit the rubber wire grommet into its cutout in the crankcase cover.



Install the 3 bolts of the stator.

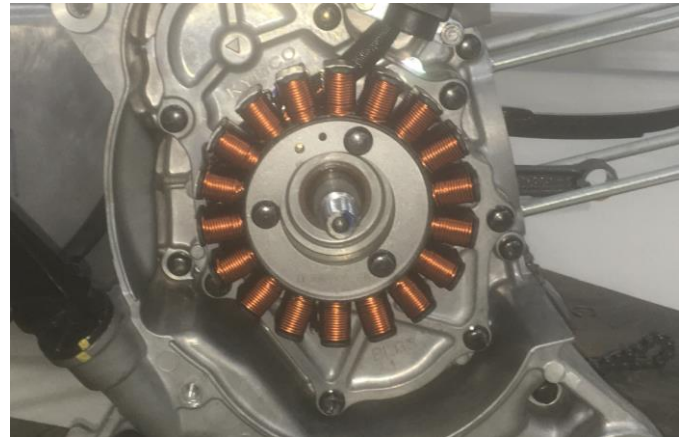

Install the 2 bolts of the Crank Position Sensor.

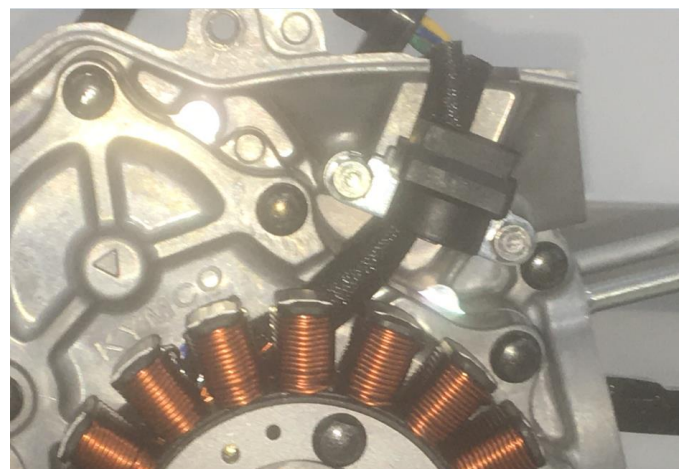



## 7. CYLINDER HEAD/VALVES CYLINDER / PISTON

### Flywheel

Lubricate the inside of the starter driven gear with fresh engine oil. Slide the starter driven gear

Onto the flywheel as shown.

Clean off the tapered end of the crankshaft where the flywheel will ride and make sure the inside of the flywheel is oil free where it will contact the crankshaft.

Line up the groove in the flywheel with the key and fit the flywheel onto the crankshaft. Guide the starter driven gear into the starter clutch on the back of the flywheel.

Install the washer and flywheel nut.

Torque the flywheel nut to specification.



Item	Qty	Thread size (mm)	Torque	
			kgf-m	N-m
ACG flywheel nut	1	12	5.0~6.0	49~58.9

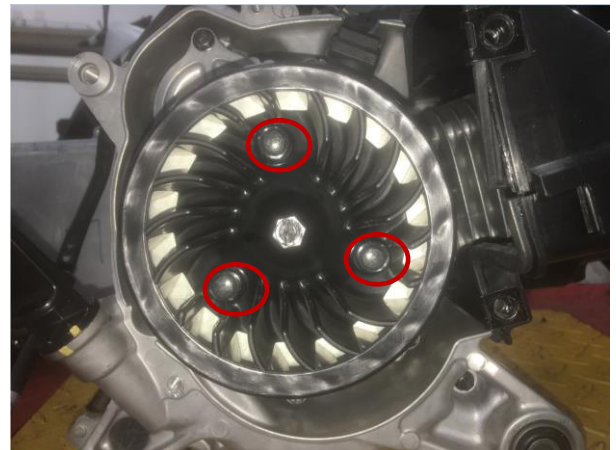

Install the fan, and tighten the 3 bolts.

Install the lower cover first, then the upper cover,  
the fan cover is the last.  
Tighten the 7 bolts.

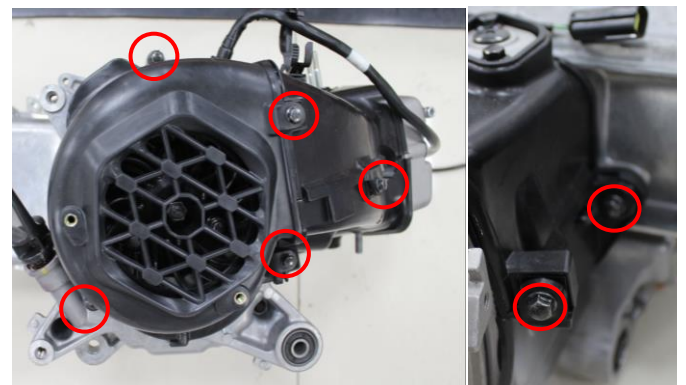

# 7. CYLINDER HEAD/VALVES CYLINDER / PISTON

## 7.12 Oil Pump

**SAFETY FIRST:** Protective gloves and eyewear are recommended at this point.

### General Instructions

The maintenance of lubrication system can be performed with the engine installed in the frame  
Use care when removing and installing the oil pump, do not allow dust and foreign matters to Enter the engine and oil line.

Do not attempt to disassemble the oil pump. The oil pump must be replaced as a set when it reaches it service limit.

After the oil pump is installed, check each part for oil leaks.

Drain the engine oil, see the engine oil chapter  
Remove the generator cover, flywheel, starter

idle gear and starter driven gear. See the AC generator and starter clutch topic.

The oil pump is driven by a chain of the crankshaft.

Remove the circlip and oil pump drive gear.

Remove the 2 bolts and the oil pump cover.

### Troubleshooting

Oil level too low

Natural oil consumption Oil leaks  
Worn or poorly installed piston rings

Worn valve guide or seal

Poor lubrication pressure

Oil level too low

Clogged filter or oil passages

Not using the specified oil

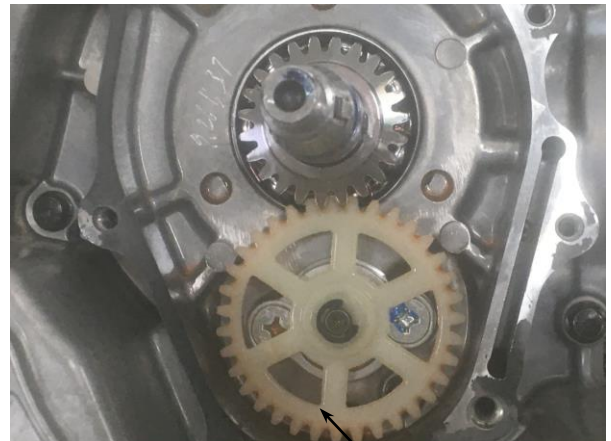

oil pump drive gear

Bolts

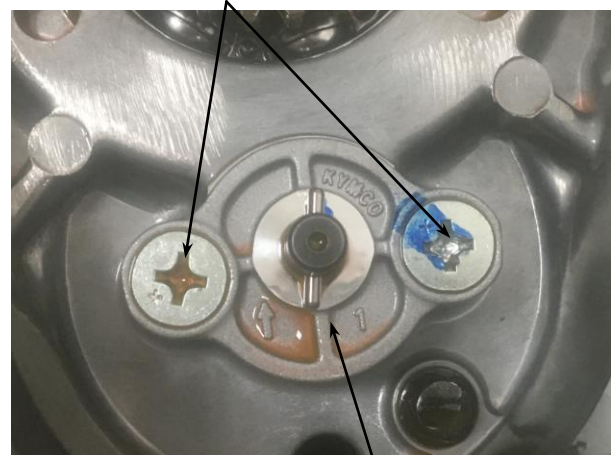

Oil Pump Cover

## 7. CYLINDER HEAD/VALVES CYLINDER / PISTON

Remove the Oil pump shaft .



Oil Pump Shaft

Remove the oil pump.



Oil Pump



## 7. CYLINDER HEAD/VALVES CYLINDER / PISTON

---

### 7.12 Crankshaft

**SAFETY FIRST:** Protective gloves and eyewear are recommended at this point.

#### Removal

Drain the engine oil and remove the strainer screen. See the Engine Oil topic for more information.

Remove the engine. See the Engine Removal chapter.

Remove the cylinder head cover. See the Cylinder Head Cover chapter.

Remove the starter motor. See the Starter Motor chapter.

Remove the CVT pulleys and belt. See the CVT Removal chapter.

Remove the cylinder head. See the Cylinder Head chapter.

Remove the cylinder and piston. See the Cylinder and Piston chapter.

Remove the generator cover, flywheel, starter idle gear and starter driven gear. See the A.C. Generator and Starter clutch chapter.

Remove the oil pump drive chain, driven sprocket and the oil pump shaft. See the Oil Pump chapter.





## 7. CYLINDER HEAD/VALVES CYLINDER / PISTON

Loosen the two crankcase bolts in a crisscross pattern with an 8 mm socket. Remove the crankcase bolts from the left side of the engine.

Separate the halves of the crankcase. If needed gently tap the reinforced areas of the right crankcase half with a rubber mallet. Lift the right crankcase off of the left.



Lift the crankshaft out of the left crankcase half. Remove the cam chain from the crankshaft and crankcase. Inspect the cam chain for wear and damage. Replace the cam chain if needed.



### Inspection

Check the side clearance of the big end of the connecting rod with a feeler gauge.

	Item	Standard mm
crankshaft	Connecting rod big end side clearance	33(-0.003~+0.011)

Grip the small end of the connecting rod and push the rod downwards and upwards, if there is definit play between the connecting rod and crank, the crankshaft should be replaced.

Inspect the crankshaft bearings for wear and damage. Replace the bearings if they show any kind of imperfection.

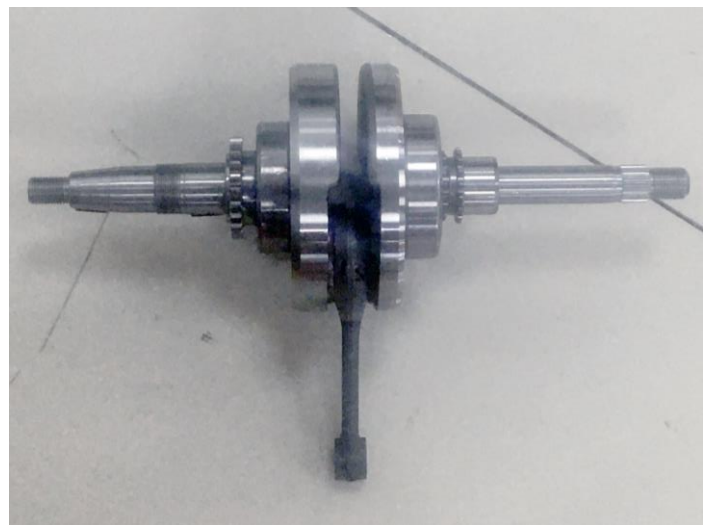



## 7. CYLINDER HEAD/VALVES CYLINDER / PISTON

Remove the left crankcase seal.



Remove the seal with a seal pick.

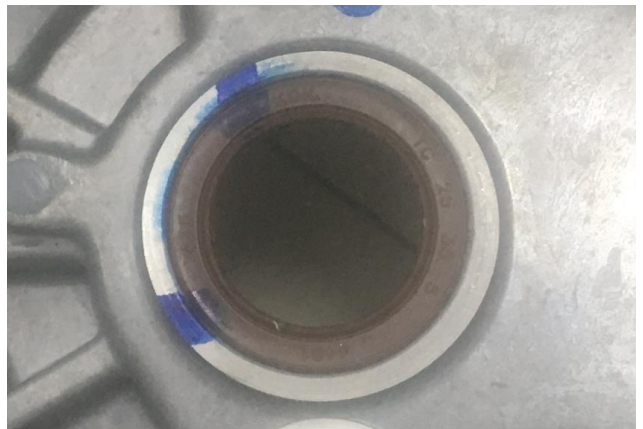

Drive a new seal into the left crankcase from outside with a suitable driver, which should have the same outside diameter with the seal.  
Lubricate the new seal lips with fresh engine oil.

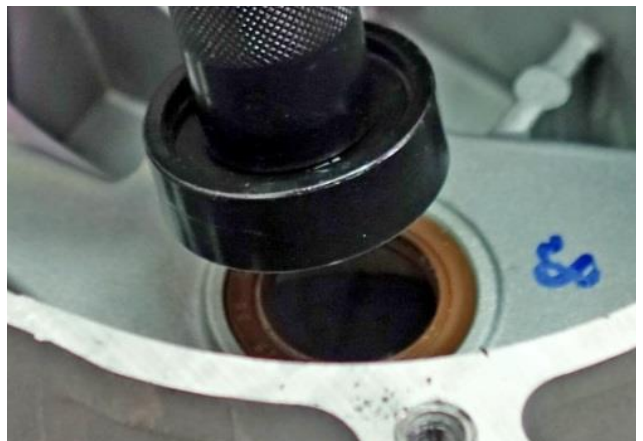

Put cam chain into the space between crankcase and the CVT case.  
Make sure the cam chain would not interfere the Camshaft when installing the camshaft.



## 7. CYLINDER HEAD/VALVES CYLINDER / PISTON

---

Install the oil pump. See the Oil Pump chapter.

Install the starter idle gear^ driven gear, flywheel, and the generator cover. See the A.C. Generator and Starter clutch topic.

Install the starter motor. See the Starter Motor chapter.

Install the CVT pulleys and belt. See the CVT Installation chapter.

Install the cylinder and piston. See the Cylinder and Piston chapter.

Install the cylinder head. See the Cylinder Head topic.

Install the camshaft. See the Camshaft chapter.

Install the cylinder head cover. See the Cylinder Head Cover chapter.

Install the rear wheel. See the Rear Wheel chapter.

Install the engine into the frame. See the Engine Installation chapter.

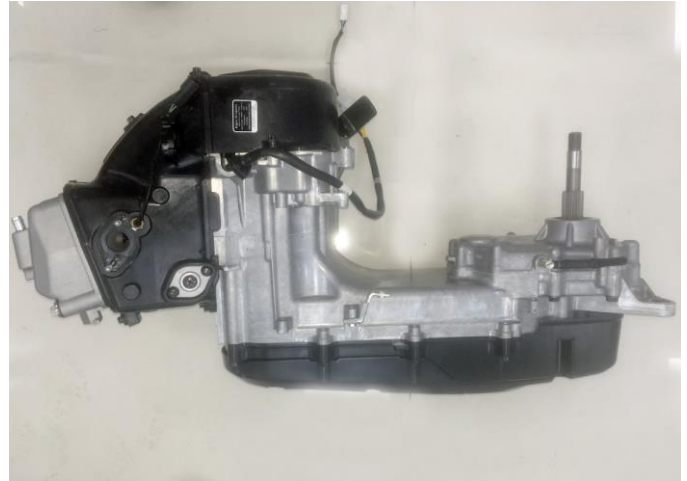

**8. DRIVEN PULLEYS**

---

---

**DRIVEN PULLEYS**

---

SERVICE INFORMATION .....	8-1
TROUBLESHOOTING .....	8-1
LEFT CRANKCASE COVER .....	8-3
DRIVE PULLEY .....	8-3
CLUTCH/DRIVEN PULLEY .....	8-8

# 8. DRIVEN PULLEYS

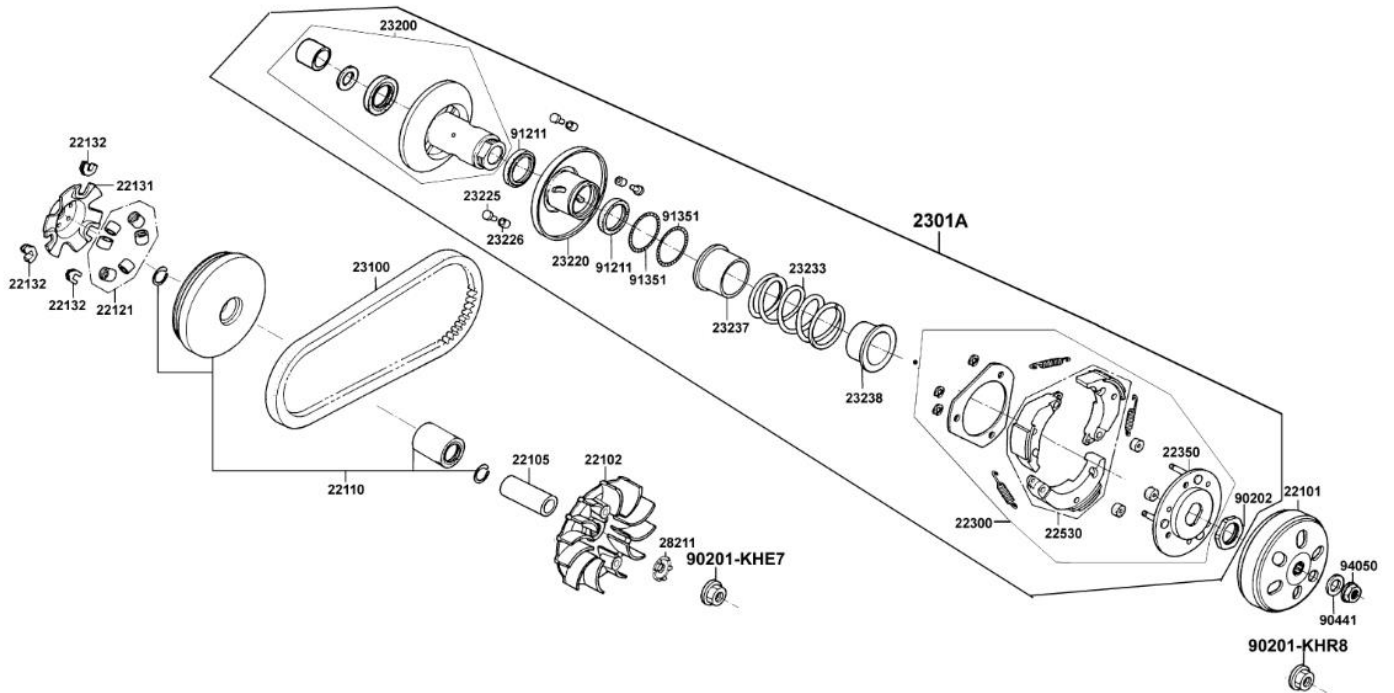

## 8. DRIVEN PULLEYS

---

### SERVICE INFORMATION

#### GENERAL INSTRUCTIONS

The drive pulley, clutch and driven pulley can be serviced with the engine installed.

Avoid getting grease and oil on the drive belt and pulley faces. Remove any oil or grease from them to minimize the slipping of drive belt and drive pulley.

#### SPECIFICATIONS

Item	Specification(mm)
Weight roller O.D(Drive pulley)	15(-0.1~0)
Clutch outer I.D	125-125.2
Clutch lining thickness	4.0

### TORQUE VALUES

Drive face nut	5.5 kg-m
Clutch outer nut	5.5 kg-m
Clutch drive plate nut	5.5 kg-m

### SPECIAL TOOLS

Universal holder	A120E00017
Outer driver, 32x35mm	A120E00015
Clutch spring compressor	A120E00027
Bearing driver	A120E00037

### TROUBLESHOOTING

#### Engine starts but motorcycle won't move

- Worn drive belt
- Broken ramp plate
- Worn or damaged clutch lining
- Broken driven face spring

#### Lack of power

- Worn drive belt
- Weak driven face spring
- Worn weight roller
- Fouled drive face

#### Motorcycle scrape during riding

- Broken clutch weight spring



## 8. DRIVEN PULLEYS

### LEFT CRANKCASE COVER

#### REMOVAL

Remove 4 bolts attaching to left crankcase cover protector.

Remove 8 bolts attaching to left crankcase cover. Remove the gasket and dowel pins.



#### INSTALLATION

Install the dowel pins.

Install the collar.

To install the left crankcase cover and tighten the left crankcase cover bolts diagonally. Connect the drive belt air tube and tighten the tube band screw.



Dowel Pins

### DRIVE PULLEY

#### REMOVAL

Remove the left crankcase cover.

Hold the drive pulley by using a universal holder and remove the drive face nut, starting ratchet and washer.

Remove the drive pulley face.

**Special**

Universal holder      A120E00017

Hold the clutch outer with an universal holder and remove the clutch outer nut.

Remove the drive belt from the clutch/driven pulley.

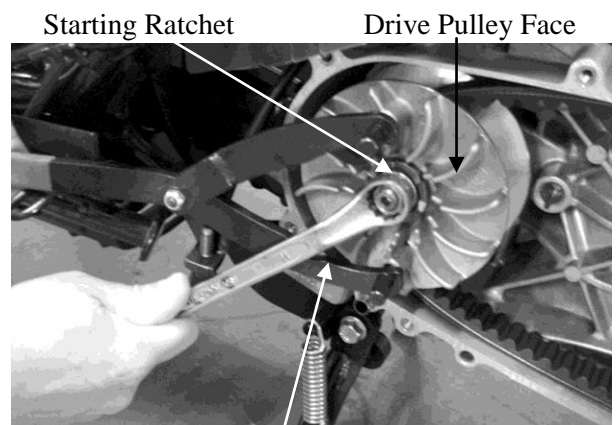

Universal Holder

Movable Drive Face Assembly

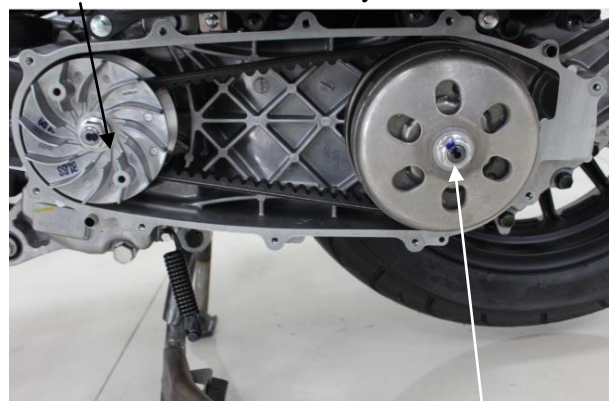

Clutch/Driven Pulley

## 8. DRIVEN PULLEYS

### INSPECTION

Check the drive belt for cracks, separation or abnormal or excessive wear.

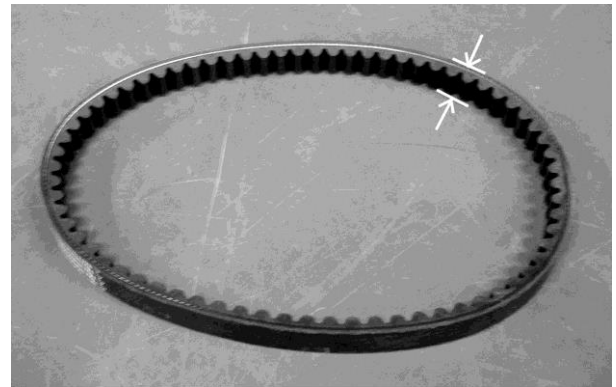

Remove the movable drive face assembly and drive pulley collar from the crankshaft.

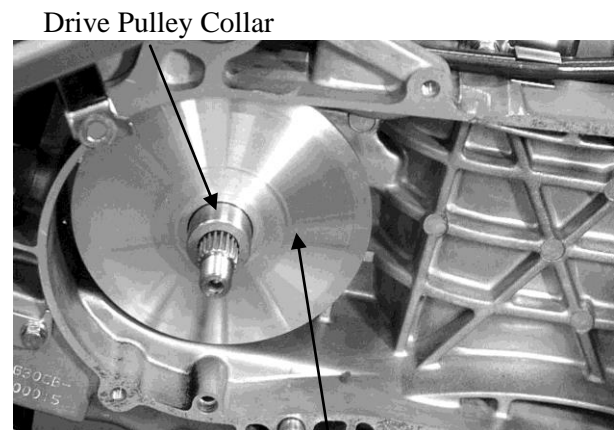

Drive Pulley Collar

Movable Drive Face Assembly

Remove the ramp plate.



Ramp Plate

Remove the weight roller.



Weight Roller

## 8. DRIVEN PULLEYS

---

### INSPECTION

Check each weight roller for wear or damage.  
Measure each weight roller O.D.

Service limit : 14.9mm replace if below



Measure the I.D. Of the movable drive face assembly

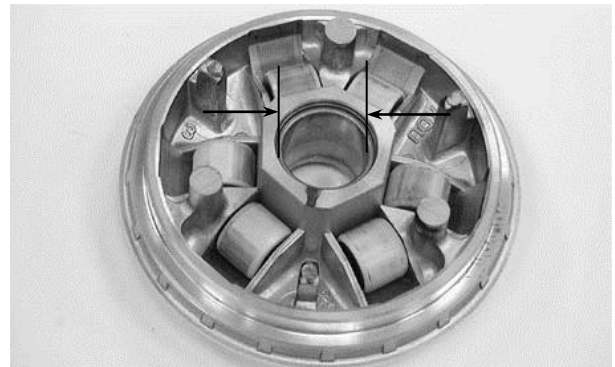

Check the drive pulley collar for wear or damage. Measure the O.D. of the drive pulley collar sliding surface.

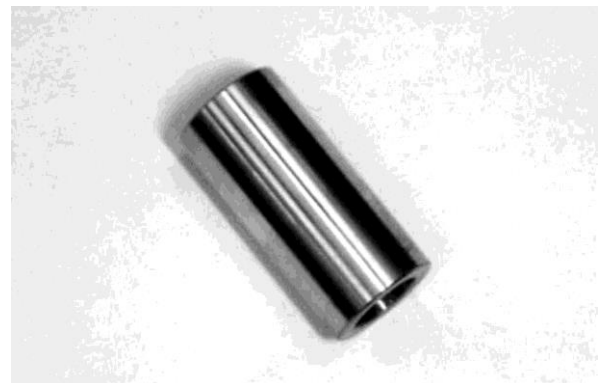

# 8. DRIVEN PULLEYS

## ASSEMBLY

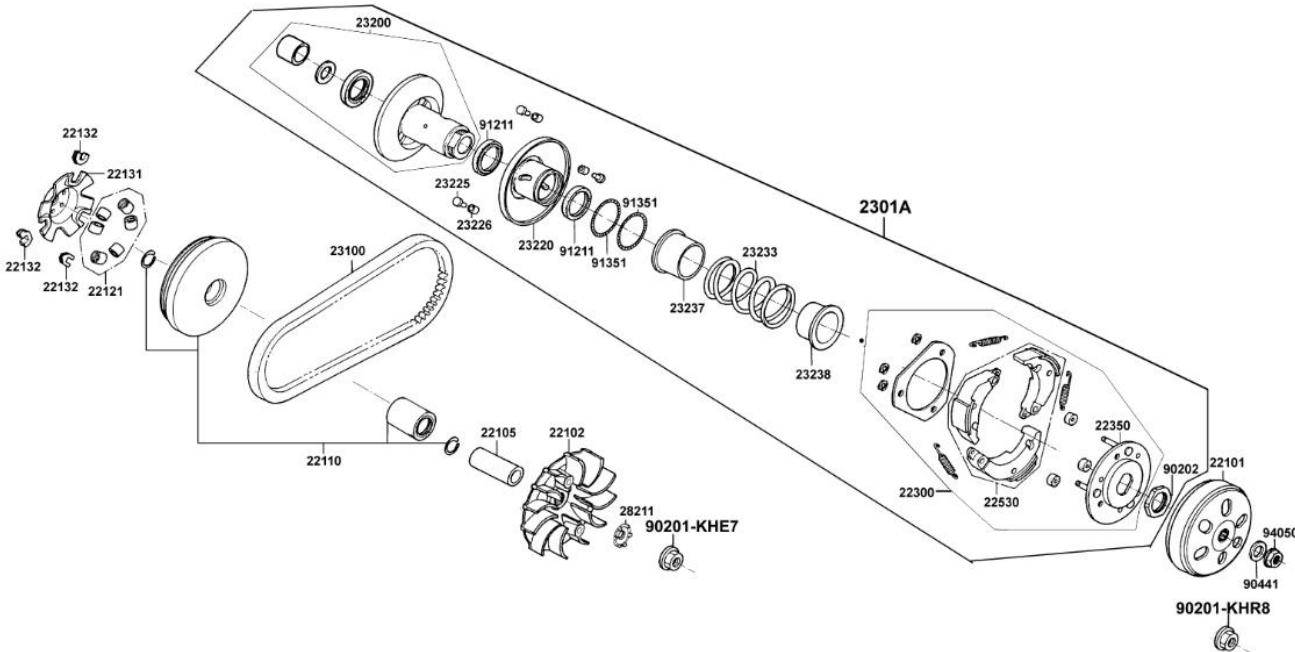

Install the weight rollers into the movable drive face.



Weight Roller

Install the ramp plate

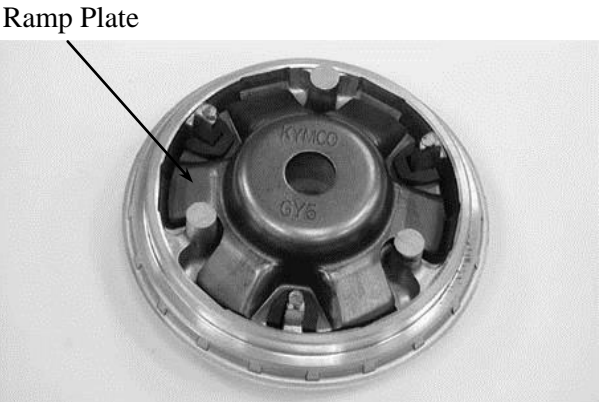

Ramp Plate

## 8. DRIVEN PULLEYS

---

Insert the drive pulley collar into the movable drive face.

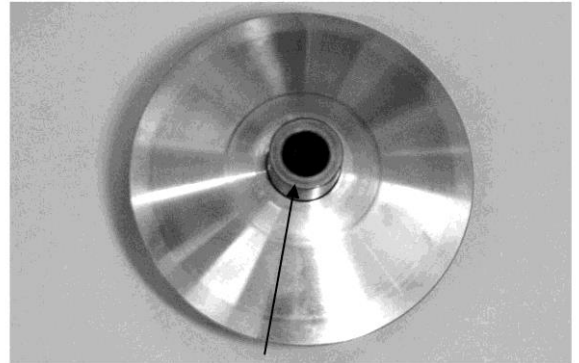

Drive Pulley Collar

### INSTALLATION

Install the movable drive face onto the crankshaft.

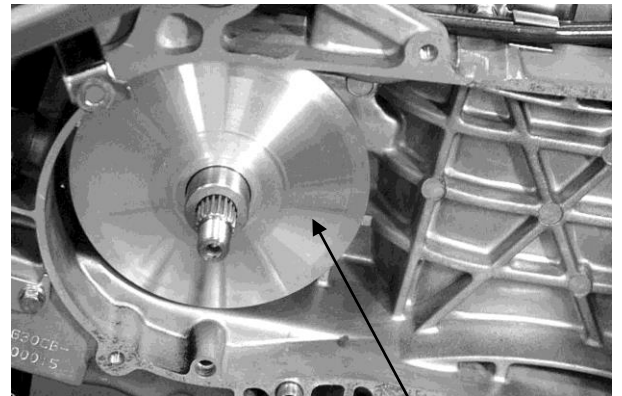

Movable Drive Face Assembly

Install the drive belt onto the clutch/driven pulley assembly and drive pulley collar. onto the clutch/driven pulley assembly and drive pulley collar.

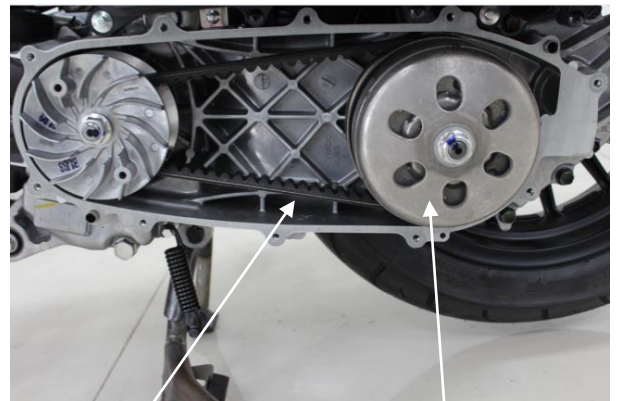

Drive Belt

Clutch/Driven Pulley



## 8. DRIVEN PULLEYS

Install the drive pulley, and nut.



Make sure to align to the crankshaft's gear when the starting ratchet installed.

Drive face nut torque: 5.0-6.0kg\*m



Nut

Hold the movable drive pulley's nut with the universal holder.

**Special**

Universal holder      A120E00017



Be careful not make the lubricant applied on the drive belt and drive pulley.

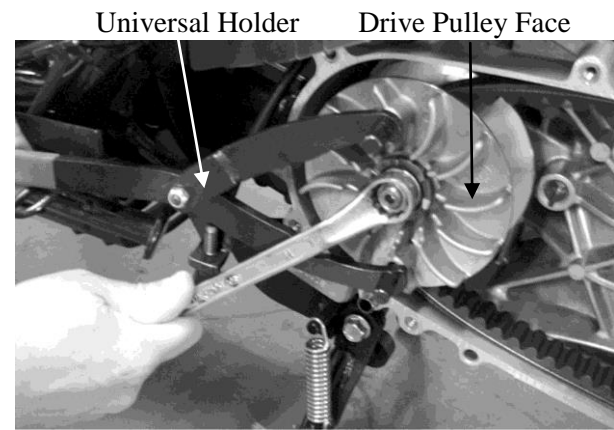

Universal Holder

Drive Pulley Face

### CLUTCH/DRIVEN PULLEY

Remove the left crankcase cover.

Remove the movable drive pulley and take off the drive belt.

Hold the clutch outer with the universal holder and remove the clutch outer nut.

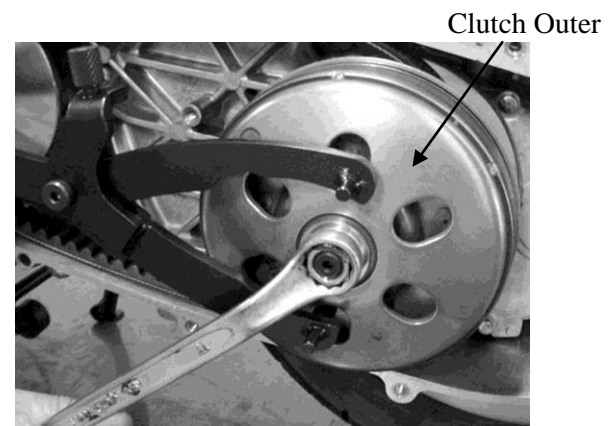

Clutch Outer

### INSPECTION

Inspect the clutch outer for wear or damage.

Measure the clutch outer I.D.

Service Limit: 125.0 mm replace if over

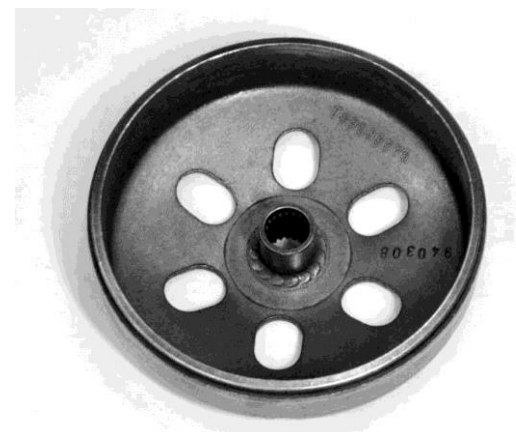

## 8. DRIVEN PULLEYS

Check the clutch lining for wear or damage.  
Measure the clutch lining thickness.

Service Limit: 1.5 mm replace if below

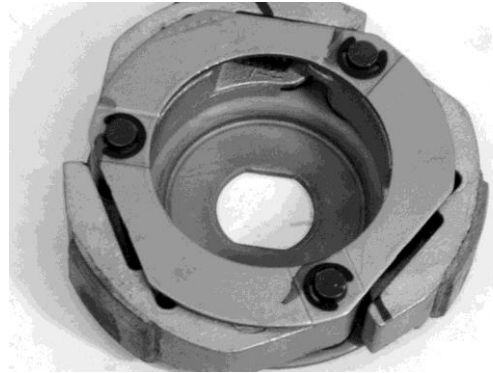

### DISASSEMBLY



Be sure to use a clutch spring compressor to avoid spring damage.



Clutch / Driven pulley

**Special**

Clutch spring compressor      A120E00027

Set the clutch spring compressor onto a vise and remove the clutch drive plate nut.

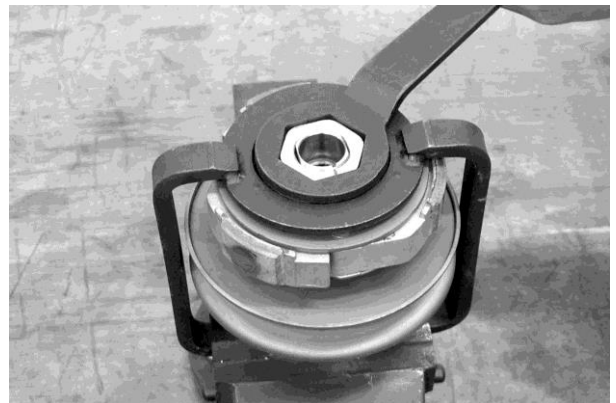

Loosen the clutch spring compressor and disassemble the clutch/driven pulley assembly.  
Remove the seal collar.



## 8. DRIVEN PULLEYS

Pull out the guide roller pins and guide rollers.  
Remove the movable driven face from the driven face.

Guide Roller Pins      Guide Roller

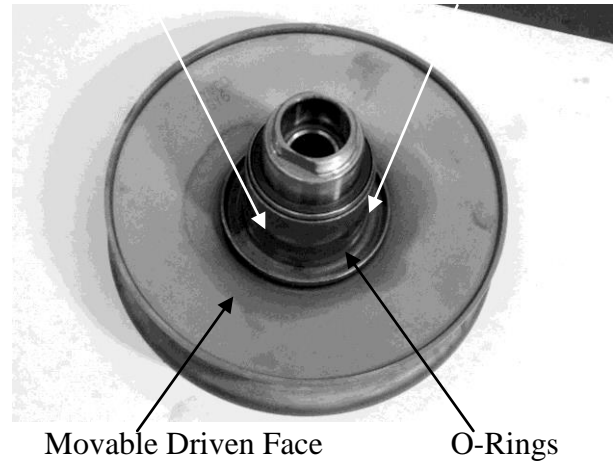

Remove the O-rings and oil seal from the movable driven face.

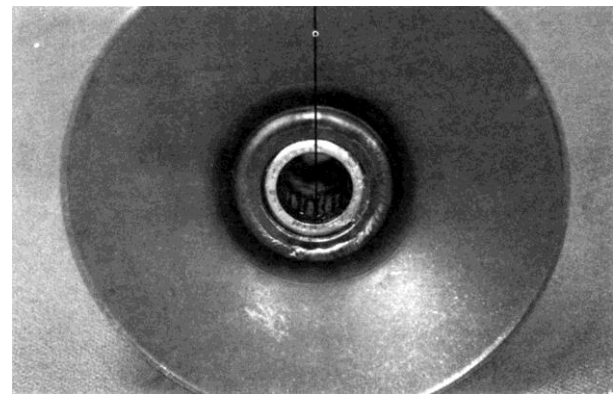

### INSPECTION

Measure the driven face spring free length.  
Replace with a new one if it is beyond service limit.

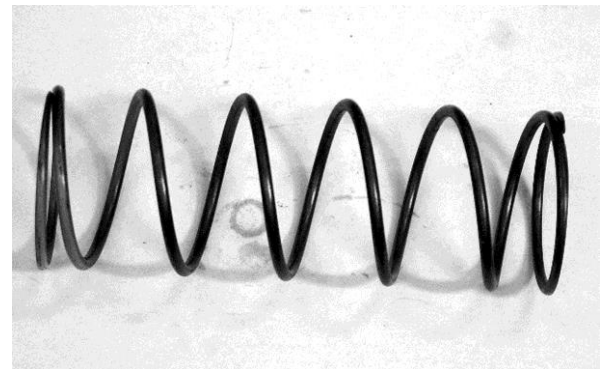

Check the driven face for wear or damage.  
Measure the driven face O.D.



## 8. DRIVEN PULLEYS

Check the movable driven face for wear or damage. Measure the movable driven face I.D.

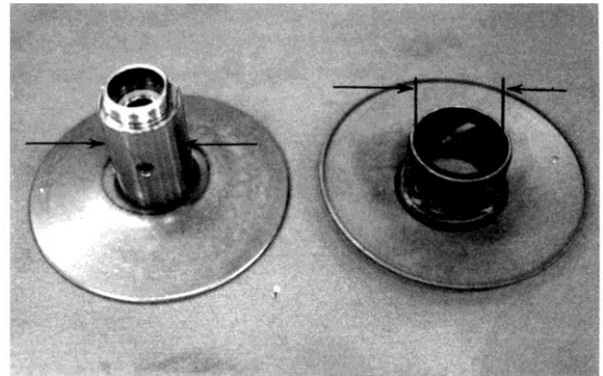

Inner Needle Bearing

Drive the inner needle bearing out of the driven pulley face.

Discard the removed bearing and replace with a new one.

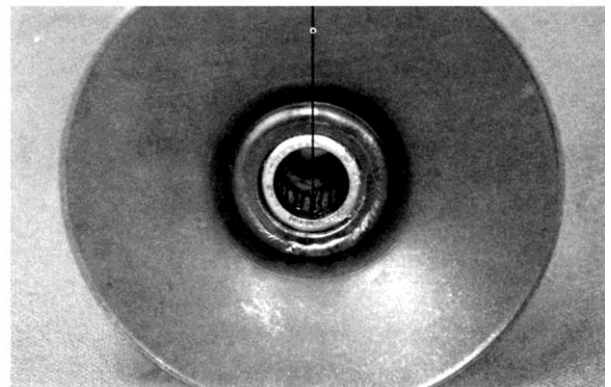

Remove the snap ring and drive the outer bearing out of the driven face.



Discard the removed bearing and replace with a new one.

**Special**

Bearing driver

A120E00037

Apply grease to the outer bearing. Drive a new outer bearing into the driven face with the sealed end facing up. Seat the snap ring in its groove.



Pack all bearing cavities with 9.0~9.5g grease.  
Specified grease: Heat resistance 230 °C

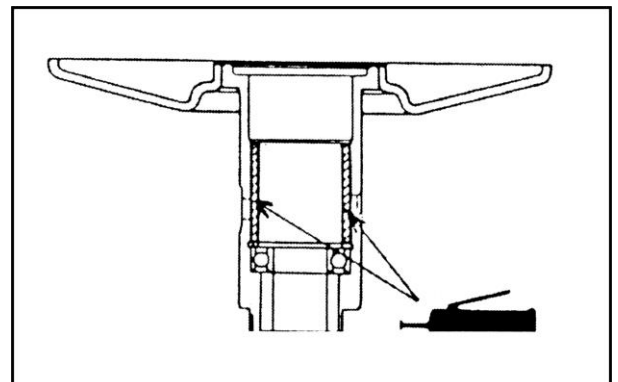

## 8. DRIVEN PULLEYS

Press a new needle bearing into the driven face.

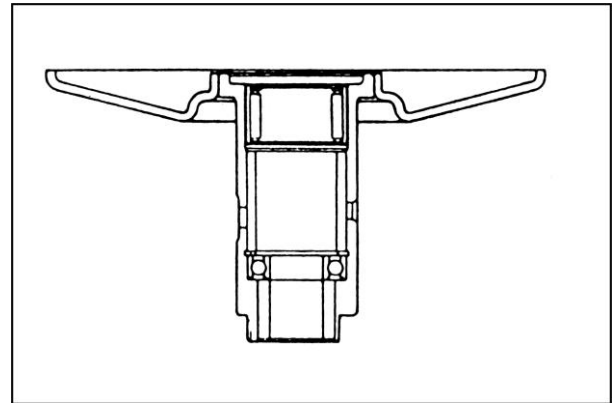

### CLUTCH DISASSEMBLY

Remove the circlips and retainer plate to disassemble the clutch.



Keep grease off the clutch linings.

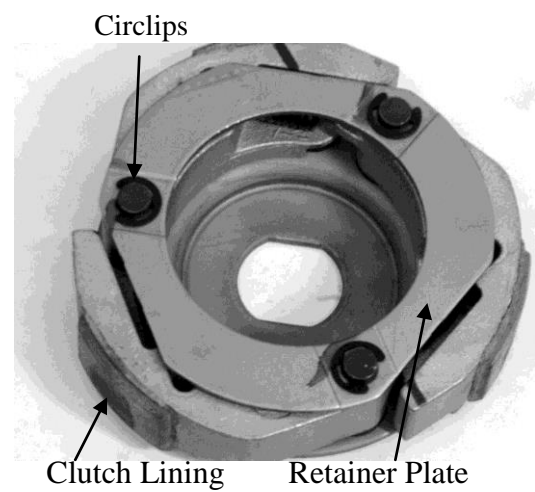



## 8. DRIVEN PULLEYS

### CLUTCH / DRIVEN PULLEY ASSEMBLY

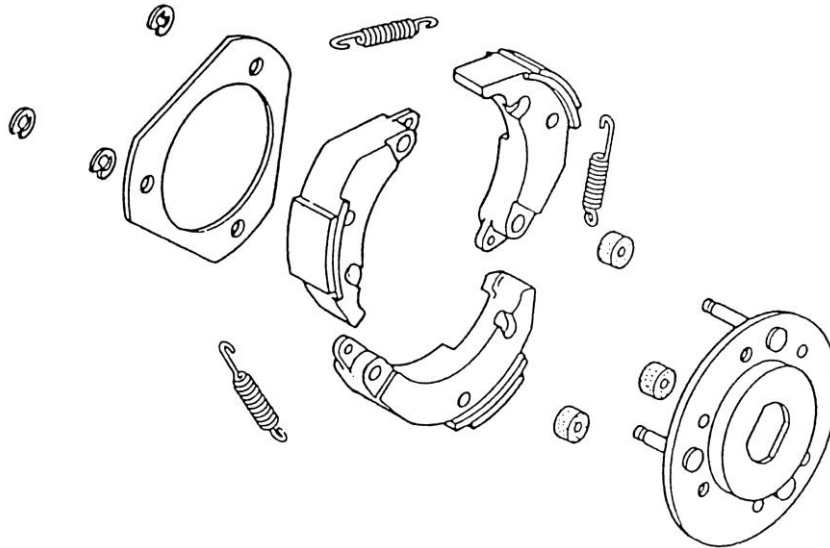

Install the damper rubbers on the drive plate pins.

Install the clutch weights/shoes and clutch springs onto the drive plate.

Install the retainer plate and secure with the circlips.

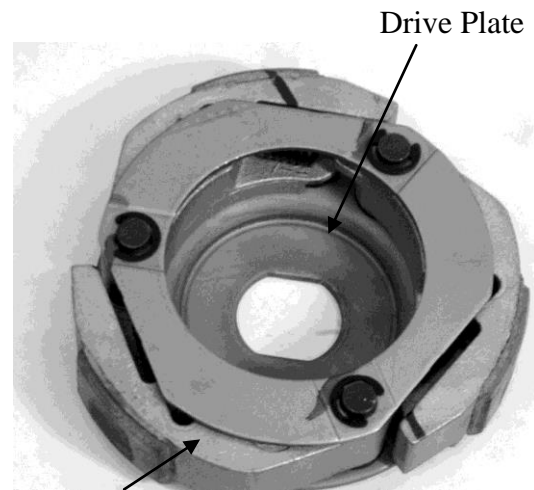

Clean the driven pulley faces and remove any grease from them.

Install the oil seal onto the moveable driven face.

Apply grease to the O-rings and install them onto the moveable driven face.

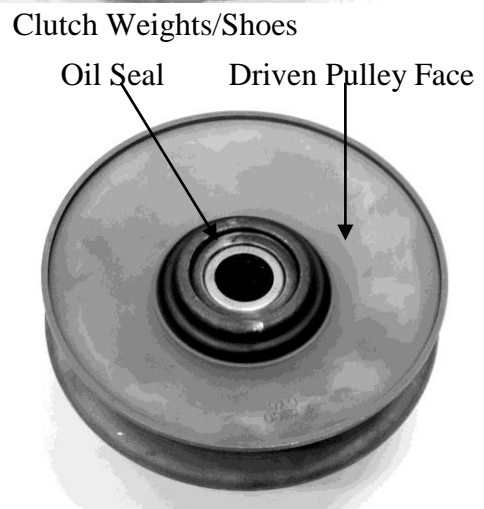

## 8. DRIVEN PULLEYS

Install the movable driven face onto the driven face.

Apply grease to the guide rollers and guide roller pins and then install them into the holes of the driven face.

Install the seal collar.

Remove any excessive grease.

\* Be sure to clean the driven face off any grease.

Set the driven pulley assembly, driven face spring and clutch assembly onto the clutch spring compressor.

\* Align the flat surface of the driven face with the flat on the clutch drive plate.

Compress the clutch spring compressor and install the drive plate nut. Set the clutch spring compressor on a vise and tighten the drive plate nut to the specified torque.

Torque: 5.5 kg-m

\* Be sure to use a clutch spring compressor to avoid spring damage.

**Special**

Clutch spring compressor A120E00027

### INSTALLATION

Install the clutch/driven pulley onto the drive shaft

\* Be sure to clean the driven face off any grease.

Guide Roller Pins

Guide Roller

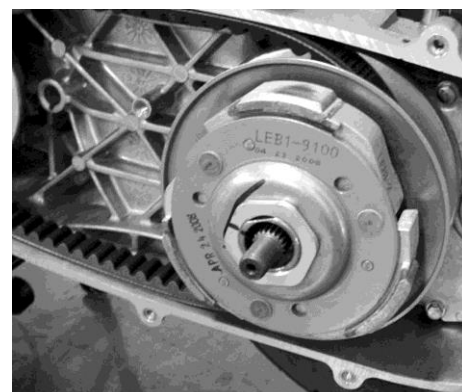
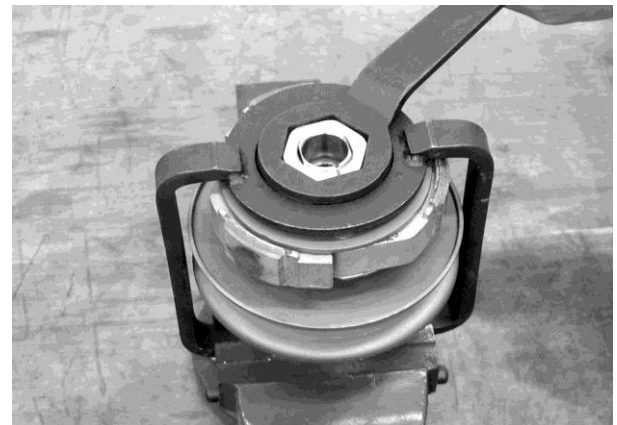
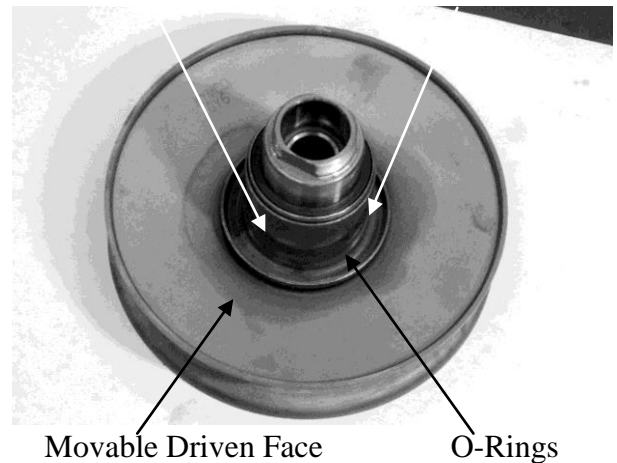

## 8. DRIVEN PULLEYS

---

Install the clutch outer.  
Hold the clutch outer with the flywheel holder.  
Install and tighten the clutch outer nut.

Torque: 5.0-6.0 kg-m

**Special**

Universal holder      A120E00017

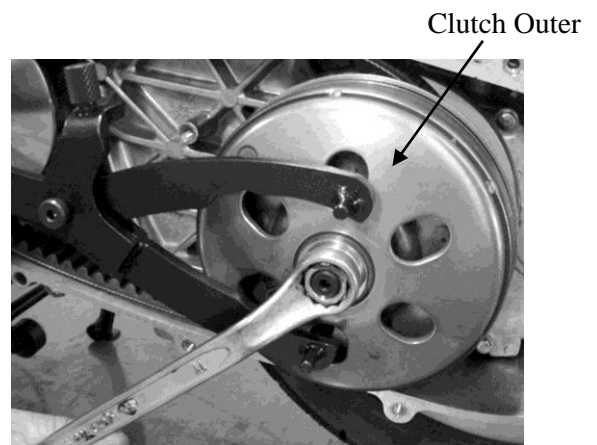

Install the drive belt.  
Install the left crankcase cover.



## **9. FINAL REDUCTION**

---

---

### **FINAL REDUCTION**

---

SERVICE INFORMATION .....	9-2
TROUBLESHOOTING .....	9-2
FINAL REDUCTION DISASSEMBLY .....	9-3
FINAL REDUCTION INSPECTION .....	9-3
FINAL REDUCTION ASSEMBLY .....	9-5

# 9. FINAL REDUCTION

---

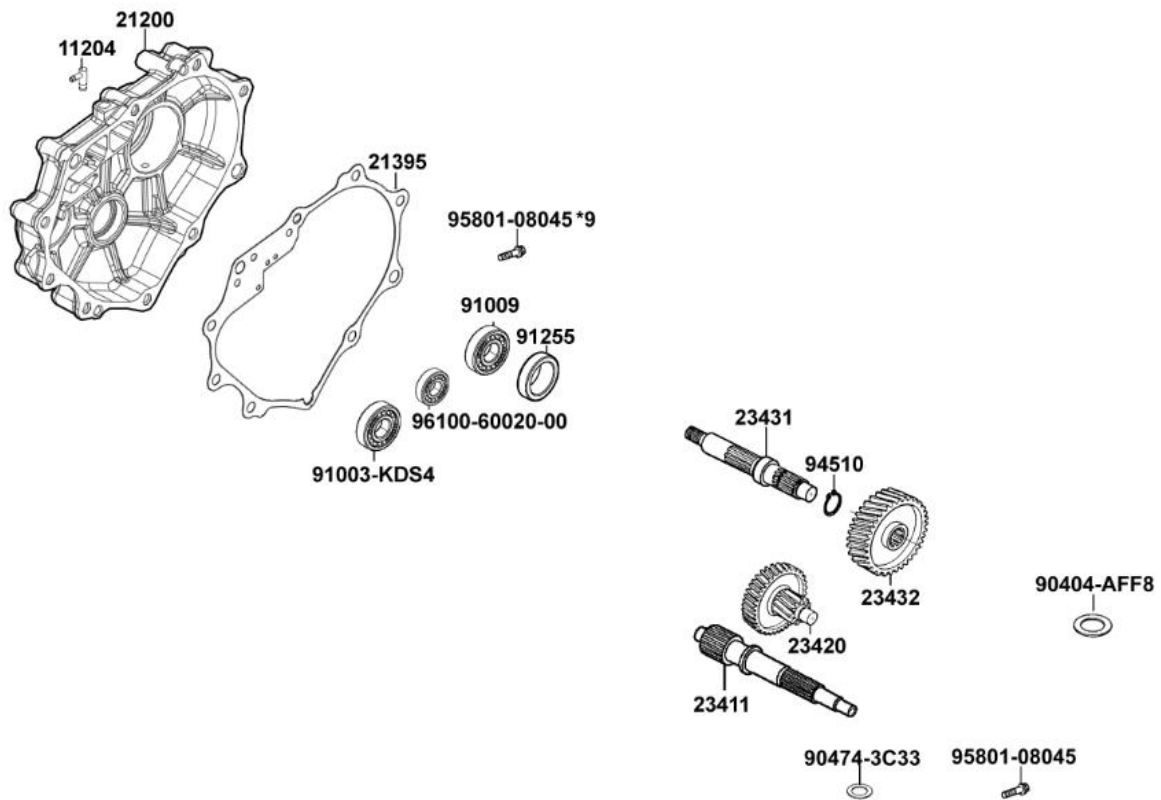



## 9. FINAL REDUCTION

---

### SERVICE INFORMATION

#### GENERAL INSTRUCTIONS

- When replacing the drive shaft, use a special tool to hold the bearing inner race for this operation.

### SPECIFICATIONS

Specified Oil: GEAR OIL SAE 90#

Oil Capacity: At change : 0.13liter

At disassembly : 0.11liter

### TORQUE VALUES

Transmission case cover bolt 1.2kg-m

### SPECIAL TOOLS

Driver handle A

Outer driver, 32x35mm

Outer driver, 37x40mm

Outer driver, 42x47mm

Pilot, 15mm

Pilot, 17mm

Pilot, 20mm

Crankcase assembly tool

– Assembly shaft

– Assembly collar

### TROUBLESHOOTING

#### Engine starts but motorcycle won't move

- Damaged transmission
- Seized or burnt transmission

#### Oil leaks

- Oil level too high
- Worn or damaged oil seal

## 9. FINAL REDUCTION

### FINAL REDUCTION DISASSEMBLY

Remove the exhaust muffler.  
Remove the rear wheel.  
Remove the air cleaner cover.  
Remove the left crankcase cover.  
Remove the clutch/driven pulley.  
Drain the transmission gear oil into a clean container.  
Remove the transmission case cover attaching bolts. (10bolts)  
Remove the transmission case cover.  
Remove the gasket and dowel pins.

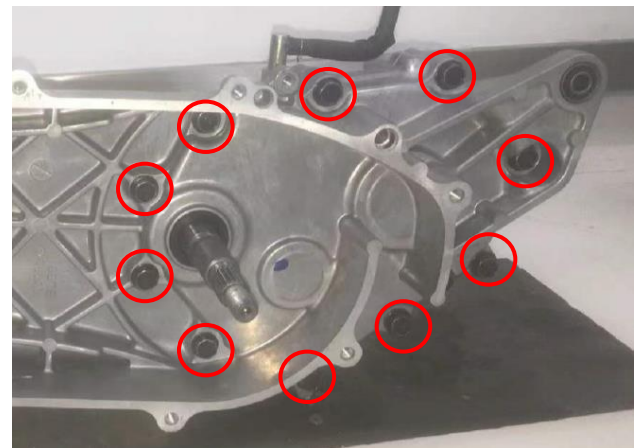

Final Gear

Remove the final gear and countershaft.

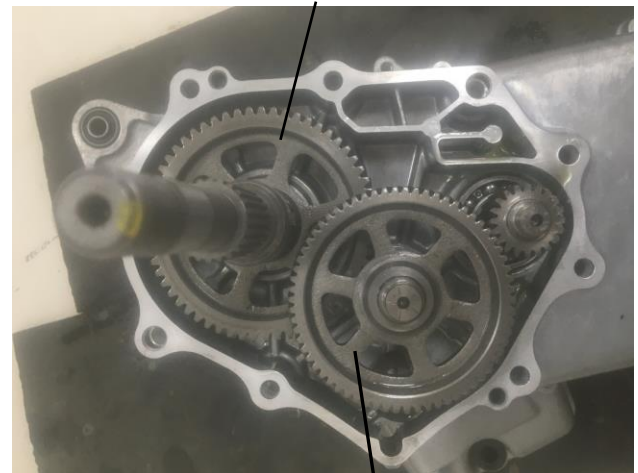

Countershaft

### FINAL REDUCTION INSPECTION

Inspect the countershaft and gear for wear or damage.

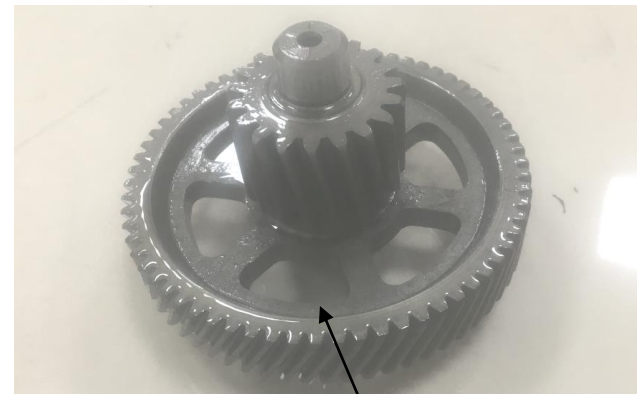

Countershaft

Inspect the final gear and final shaft for wear, damage or seizure.



## 9. FINAL REDUCTION

Check the left crankcase bearings for excessive play and inspect the oil seal for wear or damage.

Drive Shaft Bearing

Final Shaft Bearing



Countershaft Bearing

Check the transmission case cover bearings for excessive play and inspect the final shaft bearing oil seal for wear or damage.

\*

Do not remove the transmission case cover except for necessary part replacement. When replacing the drive shaft, also replace the bearing and oil seal.

Drive Shaft Bearing



Check the transmission cover bearings for excessive play. Inspect the drive shaft, drive shaft bearing and oil seal for wear or damage.



Use a bearing puller to remove the crankcase or transmission cover.



## 9. FINAL REDUCTION

Use a seal pick to remove the oil seals.



Use a bearing driver to install any new bearings into the crankcase and transmission Case cover. The drive should have the same Outside diameter as the bearings. The bearings should go in square and have their marking facing out. Drive in a new seal in the same way if needed.





## 9. FINAL REDUCTION

### Installation

Lubricate the final drive bearings with fresh final drive oil. Coat the lips of the seals with fresh final drive oil.

Press the drive shaft back into the Left crankcase as shown

Install the final gear and final shaft into the left crankcase.

Install the countershaft and gear into the left crankcase.

Install the final gear onto the final shaft as shown.





## 9. FINAL REDUCTION

---

Install the dowel pins and a new gasket.

Install and tighten the transmission case cover bolts.

make sure the gear engages correctly with the countershaft gear. Turn the drive shaft and make sure the final shaft turns.



Install the clutch/driven pulley.

Install the rear wheel.

Install the rear brake .

Install the exhaust muffler.

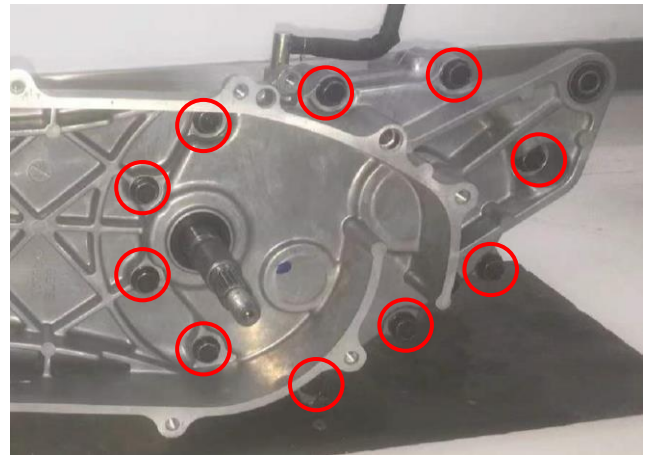

After installation, fill the transmission case with the specified oil.

Specified Gear Oil:

KYMCO SIGMA GEAR OIL SAE 90#

Oil Capacity:

At disassembly : 0.13liter

At change : 0.11 liter

Install and tighten the oil check bolt.

Torque: 1.0~1.5kg-m

Start the engine and check for oil leaks.

Check the oil level from the oil check bolt hole and add the specified oil to the proper level if the oil level is low.



---

---

---

---

---

---

**FRONT WHEEL/FRONT BRAKE/FRONT SUSPENSION**

---

**SERVICE INFORMATION..... 10-2**

**TROUBLESHOOTING ..... 10-3**

**FRONT WHEEL ..... 10-4**

**HYDRAULIC BRAKE DRAWING ..... 10-7**

**HYDRAULIC BRAKE ..... 10-8**

**FRONT SHOCK ABSORBER..... 10-13**

**STEERING HANDLEBAR ..... 10-14**

**STEERING STEM ..... 10-15**

# 10. STEERING HANDLEBAR/FRONT WHEEL/ FRONT BRAKE/FRONT SHOCK ABSORBER/FRONT FORK

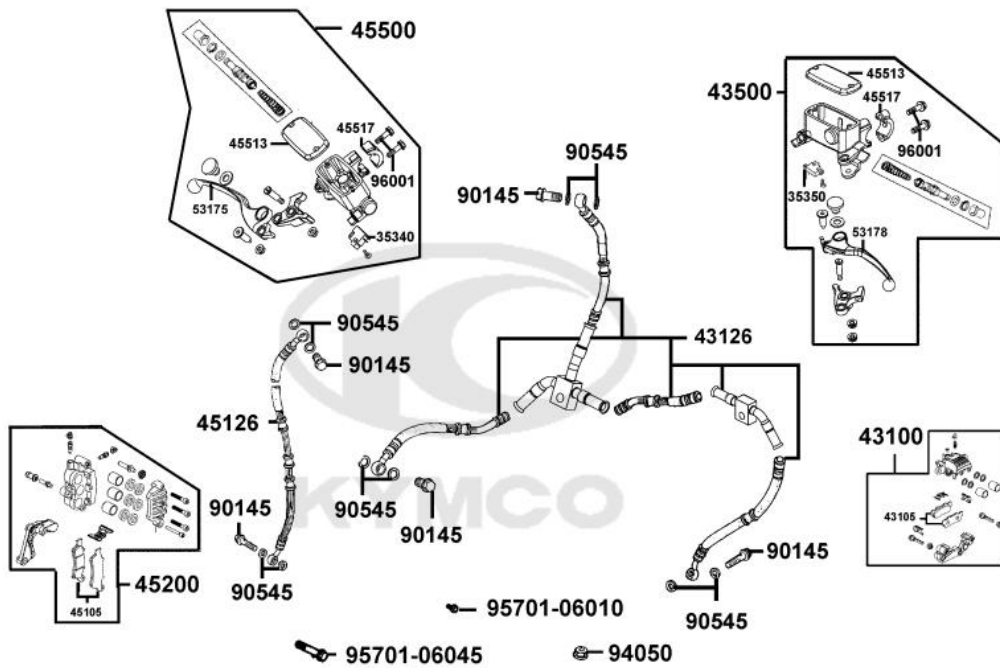
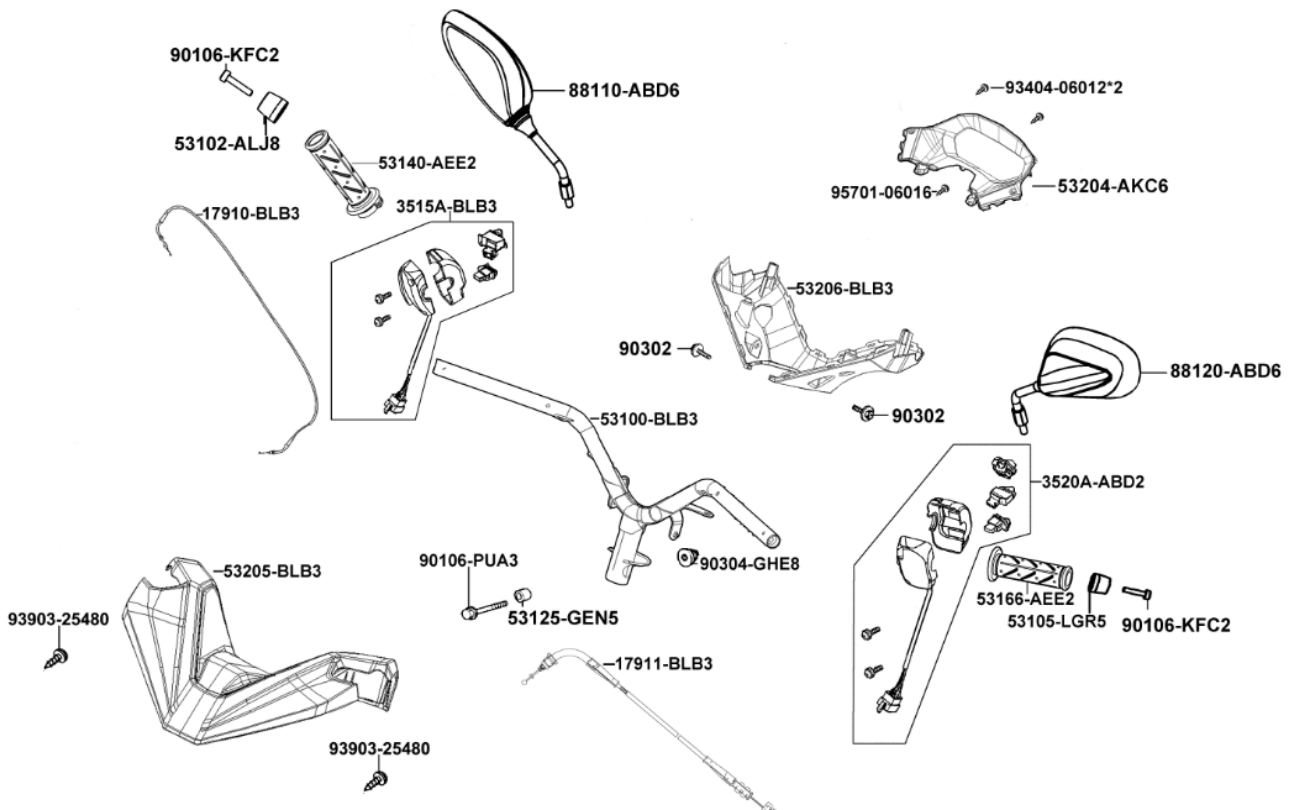

# 10. STEERING HANDLEBAR/FRONT WHEEL/ FRONT BRAKE/FRONT SHOCK ABSORBER/FRONT FORK



Skytown 125

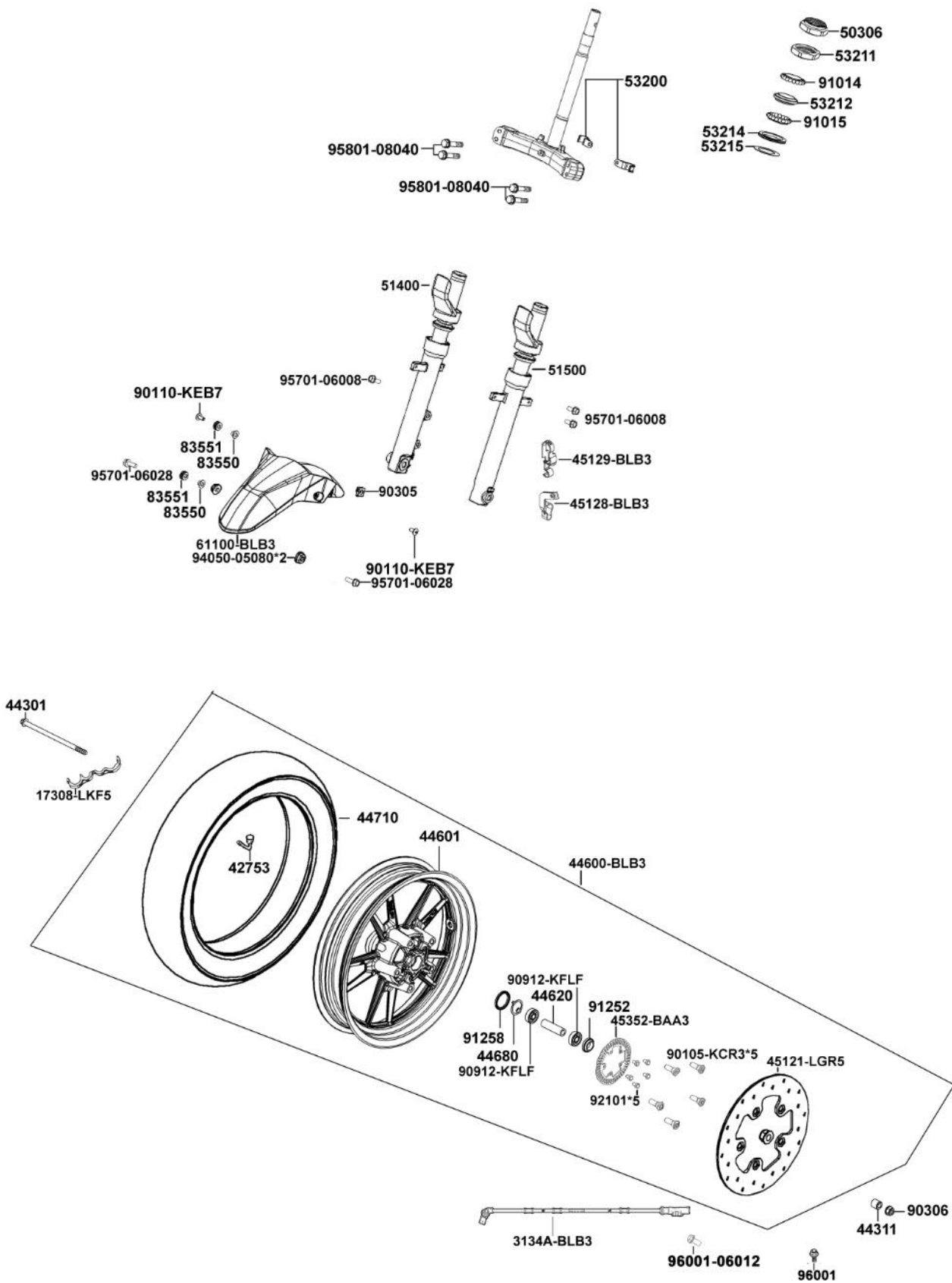

**SERVICE INFORMATION**

**GENERAL INSTRUCTIONS**

- Remove the motorcycle front wheel off the ground and be careful to prevent the motorcycle from falling down.
- During servicing, keep oil or grease off the brake drum and brake linings.
- Contaminated brake disk or brake pads reduce stopping power. Clean the contaminated brake disk with high-performance brake degreaser and replace the brake pads.
- Do not use brake fluid for cleaning.
- Bleed air from the brake system if the brake system is removed or the brake is soft.
- Do not allow any foreign matters to enter the brake system when filling it with brake fluid.
- Brake fluid will damage painted surfaces and plastic parts. When servicing the brake system, use shop towels to cover and protect rubber, plastic parts and coated surfaces. Wipe off any spilled brake fluid with a clean shop towel.
- Inspect the brake system before riding.

**SPECIFICATIONS**

Item	Standard (mm)	
Axle shaft run out	—	
Front wheel rim run out	Radial	—
	Axial	—
Front brake lining thickness	5.5	
Brake disk runout	—	
Brake master cylinder I.D.	12.700~12.743	
Brake master cylinder piston O.D.	12.657~12.684	
Brake caliper piston O.D.	25.33~25.36	
Brake caliper cylinder I.D.	25.4~25.45	

**TORQUE VALUES**

Steering stem bolt	4.0~5.0kg-m	Brake caliper bleed valve	0.6kg-m
Steering stem lock nut	7.0~8.0kg-m	Brake fluid tube bolt	3.0~4.0kg-m
Steering top cone race	0.5~1.3kg-m	Brake pad pin bolt	1.5~2.0kg-m
Front shock absorber bolt	2.0~2.5kg-m	Brake caliper bolt	2.9~3.5kg-m
Front axle nut	5.0~7.0kg-m	Brake master cylinder bolt	1.0~1.4kg-m



**SPECIAL TOOLS**

Lock nut wrench

Outer driver, 28x30mm

Ball race remover

Pliers (close)

Bearing remover head, 10mm

Driver handle A

Pilot, 10mm

Outer driver, 37x40mm

Bearing remover

**TROUBLESHOOTING**

**Hard steering (heavy)**

- Excessively tightened steering stem top cone race
- Broken steering balls
- Insufficient tire pressure

**Steers to one side or does not track straight**

- Uneven front shock absorbers
- Bent front fork
- Bent front axle or uneven tire

**Poor brake performance**

- Incorrectly adjusted brake
- Worn brake linings
- Contaminated brake lining surface
- Worn brake shoes at cam contacting area
- Worn brake drum
- Poorly connected brake arm

**Poor brake performance (Disk Brake)**

- Air in brake system
- Deteriorated brake fluid
- Contaminated brake pads and brake disk
- Worn brake pads
- Worn brake master cylinder piston oil seal
- Clogged brake fluid line
- Deformed brake disk
- Unevenly worn brake caliper

**Front wheel wobbling**

- Bent rim
- Excessive wheel bearing play
- Bent spoke plate
- Faulty tire
- Improperly tightened axle nut

**Soft front shock absorber**

- Weak shock springs
- Insufficient damper oil

**Front shock absorber noise**

- Slider bending
- Loose fork fasteners
- Lack of lubrication

# 10. STEERING HANDLEBAR/FRONT WHEEL/ FRONT BRAKE/FRONT SHOCK ABSORBER/FRONT FORK

## FRONT WHEEL

### REMOVAL

Remove the front wheel off the ground.  
Remove the front axle nut and pull out the axle.  
Remove the front wheel.



Axle Nut



Axle Shaft

### INSPECTION

#### AXLE RUNOUT

Set the axle in V blocks and measure the runout using a dial gauge.  
The actual runout is 1/2 of the total indicator reading.

**Service Limit:** 0.2mm replace if over

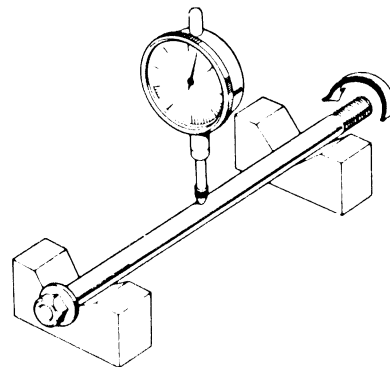

#### WHEEL RIM

Check the wheel rim run-out.

#### **Service Limits:**

**Radial:** 2.0mm replace if over

**Axial:** 2.0mm replace if over

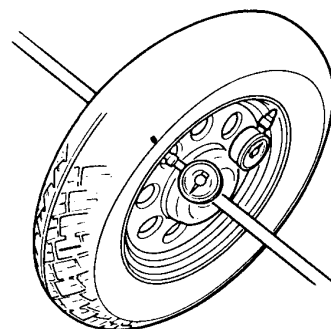

**FRONT WHEEL BEARING**

Remove the side collar (1) and dust seal (2).

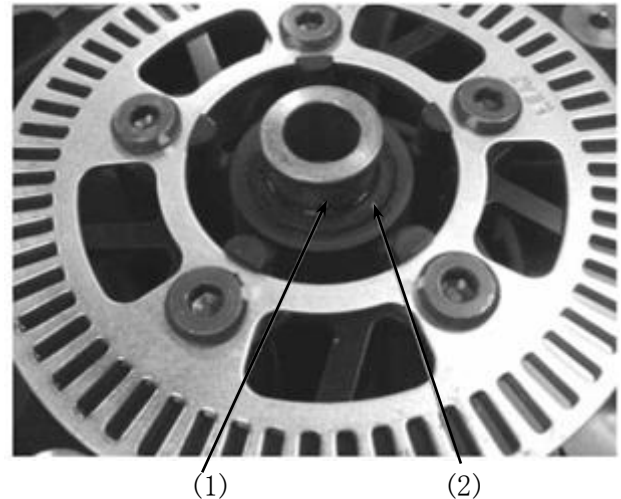

Turn the inner race of each bearing with your finger to see if they turn smoothly and quietly. Also check if the outer race fits tightly in the hub. Replace the bearings if the races do not turn smoothly, quietly, or if they fit loosely in the hub.

Remove the front wheel bearing (3) by using the special tool.

**Special tool:**  
Bearing puller                    A120E00037

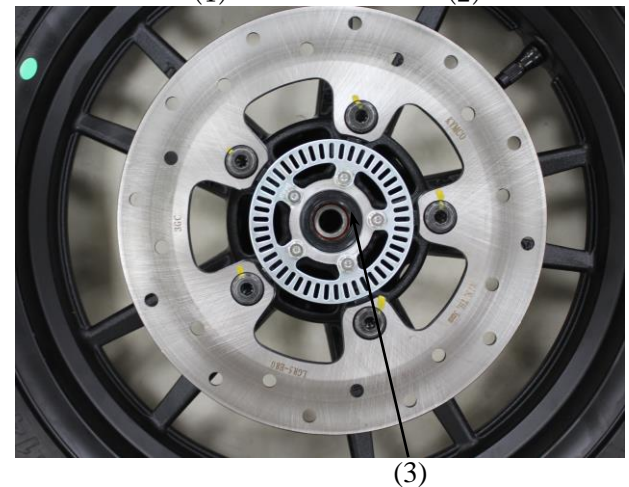

Remove the distance collar from wheel.

Remove the front wheel bearing (4) by using the special tool.

**Special tool:**  
Bearing puller                    A120E00037

**ASSEMBLY**

Install the front wheel bearing (3) (4) by using the special tool.

**Special tool:**  
Bearing puller                    A120E00014

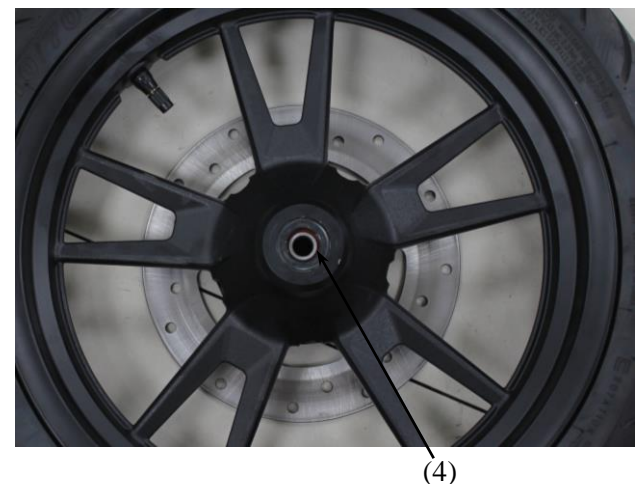

Install the distance collar.

# 10. STEERING HANDLEBAR/FRONT WHEEL/ FRONT BRAKE/FRONT SHOCK ABSORBER/FRONT FORK

Apply grease to a new dust seal lip and install the dust seal.  
Install the side collar.



Collar (left)

## INSTALLATION

Apply a thin coat of grease to the axle shaft.  
Install the front wheel.  
Insert the axle shaft.



Collar (right)

Install and tighten the axle nut.  
Torque: 5.0~7.0kg-m

Rotate the front tire to check the speedometer if  
be performed.



Axle Nut

**HYDRAULIC BRAKE DRAWING**

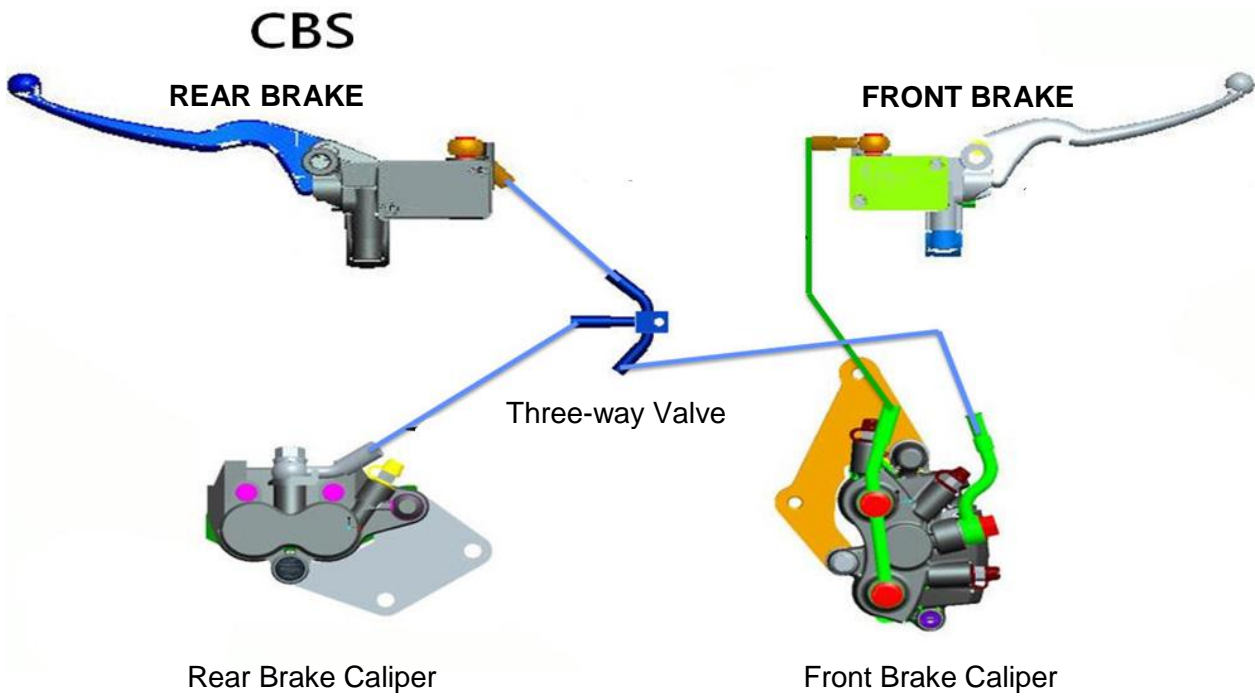



**HYDRAULIC BRAKE**

**BRAKE FLUID REPLACEMENT/AIR BLEEDING**

Check the brake fluid level on level ground.

**\***

- When operating the brake lever, the brake reservoir cap must be tightened securely to avoid splash of brake fluid.
- When servicing the brake system, use shop towels to cover plastic parts and coated surfaces to avoid damage caused by splash of brake fluid.



Lower Limit

**BRAKE FLUID BLEEDING**

In order to avoid spilling brake fluid, connect a transparent hose to the bleed valve.



**Warning**

Spilled brake fluid on brake pads or brake disk reduces stopping power. Clean the brake pads and brake disk with a high-performance brake degreaser.



Fully apply the brake lever and then loosen the brake caliper bleed valve to drain the brake fluid until there is no air bubbles in the brake fluid. Then, tighten the bleed valve. Repeat these steps until the brake system is free of air.

**BRAKE FLUID REFILLING**

Add DOT-4 brake fluid to the brake reservoir.

**\***

- When bleeding, be careful not to allow air in the brake reservoir flowing into the brake system.
- Never use dirty or unspecified brake fluid or mix different brake fluids because it will damage the brake system.



Rear Brake Bleed Valve

Front Brake Bleed Valve

fixed-reed

Make sure to bleed air from the brake system.

**BRAKE PAD/DISK REPLACEMENT**

**\***

The brake pads must be replaced as a set to ensure the balance of the brake disk.

Remove the two bolts attaching the brake caliper. Remove the brake caliper. Compress the brake caliper seat, and press down the fixed-reed to take out the brake pads.



# 10. STEERING HANDLEBAR/FRONT WHEEL/ FRONT BRAKE/FRONT SHOCK ABSORBER/FRONT FORK

Install the brake pads in the reverse order of removal.

Tighten the brake pad pin bolt.

**Torque:** 1.5~2.0kg-m

\* Keep grease or oil off the brake pads to avoid brake failure.

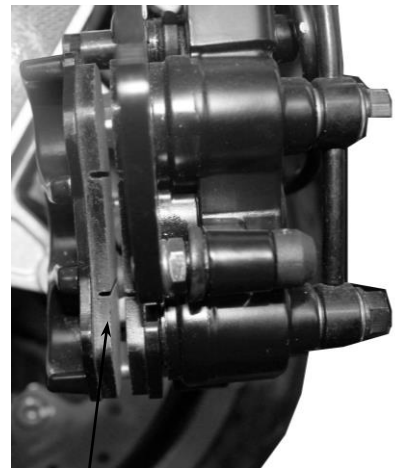

Brake Pads

## BRAKE DISK

Measure the brake disk thickness.

**Service Limit:** 3.5mm

Measure the brake disk runout.

**Service Limit:** 0.3mm



## BRAKE MASTER CYLINDER

### REMOVAL

First drain the brake fluid from the hydraulic brake system.

- \* 
  - When servicing the brake system, use shop towels to cover rubber and plastic parts and coated surfaces to avoid being contaminated by brake fluid.
  - When removing the brake fluid tube bolt, be sure to plug the tube end to avoid brake fluid leakage.



Master Cylinder

### DISASSEMBLY

Remove the piston rubber cover and snap ring from the brake master cylinder.



Snap Ring

Remove the main piston and spring from the brake master cylinder.

Clean the inside of the master cylinder and brake reservoir with brake fluid.

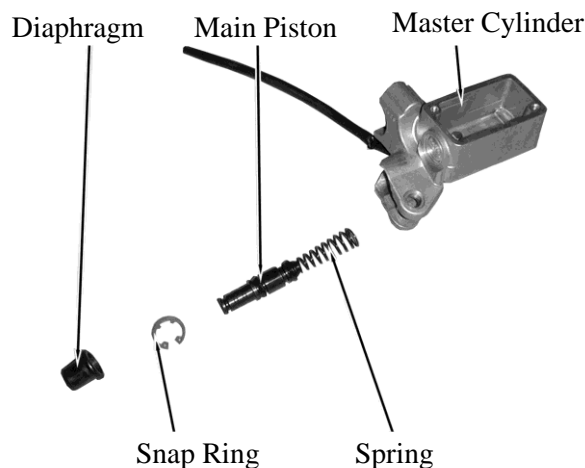

**INSPECTION**

Measure the brake master cylinder I.D.  
Inspect the master cylinder for scratches or cracks.

**Service Limit:** 12.75mm



Measure the brake master cylinder piston O.D.

**Service Limit:** 12.64mm

Before assembly, inspect the 1st and 2nd rubber cups for wear or damage.

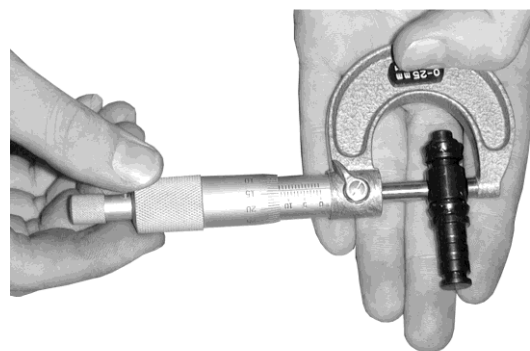

**ASSEMBLY**

Before assembly, apply brake fluid to all removed parts.

Install the spring together with the 1st rubber cup.

- \***
- During assembly, the main piston and spring must be installed as a unit without exchange.
  - When assembling the piston, soak the cups in brake fluid for a while.
  - Install the cups with the cup lips facing the correct direction.

Install the main piston, spring and snap ring.

Install the diaphragm.

Install the brake lever.

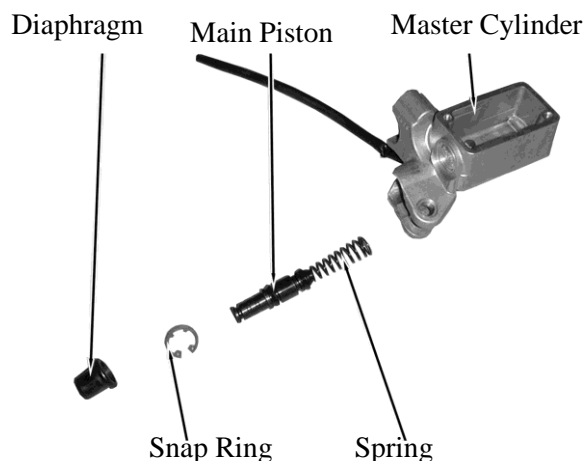

# 10. STEERING HANDLEBAR/FRONT WHEEL/ FRONT BRAKE/FRONT SHOCK ABSORBER/FRONT FORK

Place the brake master cylinder on the handlebar and install the holder with the “up” mark facing up. Also align the punch mark with the holder joint seam.

First tighten the upper bolt and then tighten the lower bolt.

**Torque:** 1.0~1.4kg-m

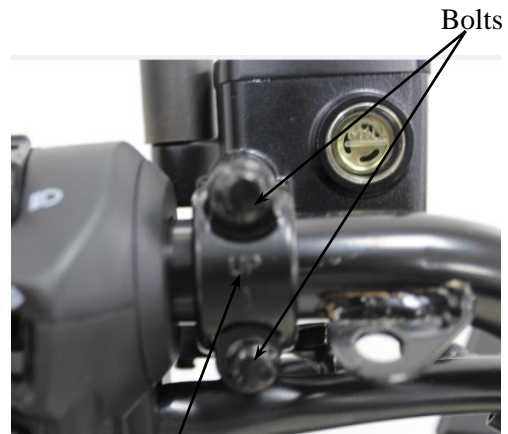

“Up” Mark

Washers

Install the brake fluid tube with the attaching bolt and two sealing washers.

Install the handlebar covers.

Connect the front and rear stop switch wire connectors.

Fill the brake reservoir with recommended brake fluid to the upper limit and bleed air according to the method stated in page 12-8.



Fluid Tube Bolt

## BRAKE CALIPER

### REMOVAL

Remove the brake caliper and brake pad springs. Place a clean container under the brake caliper and disconnect the brake fluid pipe from the caliper.

\* Do not spill brake fluid on any coated surfaces.



Bolts

### DISASSEMBLY

Remove the brake caliper seat from the brake caliper.

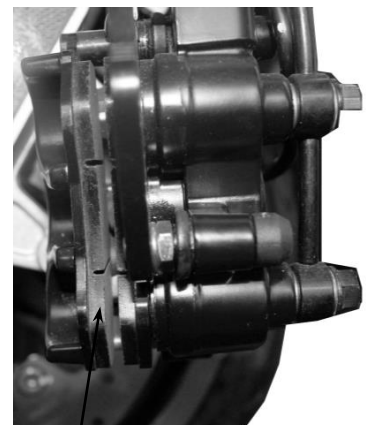

Brake Pads

Remove the pistons from the brake caliper.  
If necessary, use compressed air to squeeze out the pistons through the brake fluid inlet opening and place a shop towel under the caliper to avoid contamination caused by the removed pistons.  
Check each piston cylinder for scratches or wear and replace if necessary.

\* Be careful not to damage the piston surface.

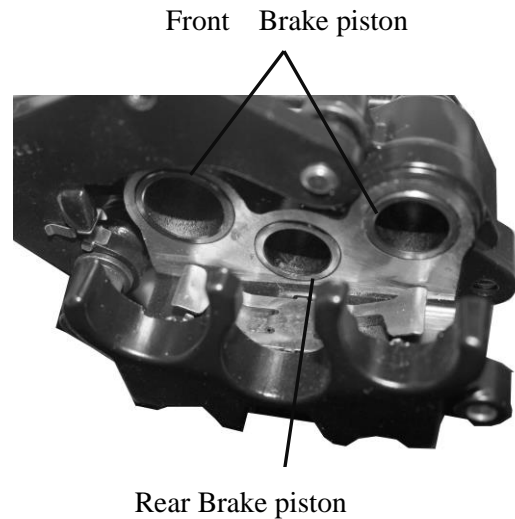

Check each piston for scratches or wear.  
Measure each piston O.D. with a micrometer gauge.

**Service Limit:**  
25.35mm

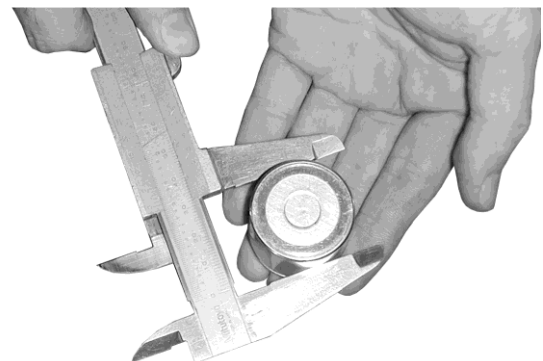

Check each caliper cylinder for scratches or wear and measure the cylinder bore.





# 10. STEERING HANDLEBAR/FRONT WHEEL/ FRONT BRAKE/FRONT SHOCK ABSORBER/FRONT FORK

## ASSEMBLY

Clean all removed parts.

Apply silicon grease to the pistons and oil seals.  
Lubricate the brake caliper cylinder inside wall  
with brake fluid.

Install the brake caliper piston with grooved side  
facing out.

\* Install the piston with its outer end  
protruding 3~5mm beyond the brake  
caliper cylinder.

Wipe off excessive brake fluid with a clean shop  
towel. Apply silicon grease to the brake caliper  
seat pin and caliper inside.  
Install the brake caliper seat.

## INSTALLATION

Install the brake caliper and tighten the two bolts.

**Torque:** 2.9~3.5kg-m

Connect the brake fluid tube to the brake caliper  
and tighten the fluid tube bolt.

**Torque:** 3.0~4.0kg-m

Fill the brake reservoir with recommended brake  
fluid and bleed air from the brake system.

## FRONT SHOCK ABSORBER

### REMOVAL

Remove the front cover.

Remove the front wheel.

Remove the front shock absorber upper mount  
bolts.

Loosen the lower mount bolts to remove the front  
shock absorbers.



Fixed-Reed



Caliper Bolts

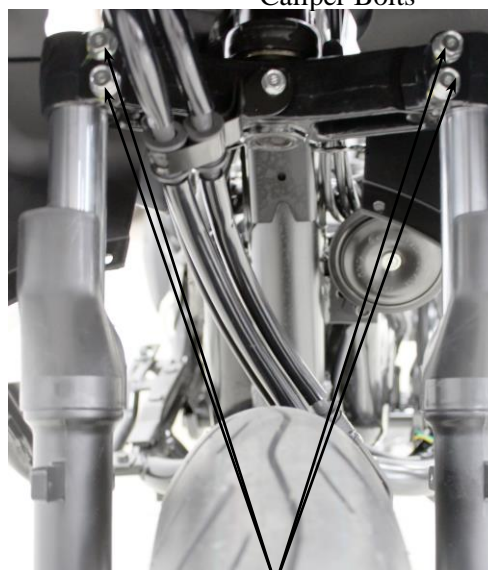

Mount Bolt

**INSPECTION**

Inspect the following items and replace if necessary.

- Front shock absorber tube bending or damage.
- Weak front shock absorber spring.
- Damper and damper rod bending.
- Oil seal damage or wear.

Specified Oil: SS#8  
Oil Capacity: 80 ± 1 cc

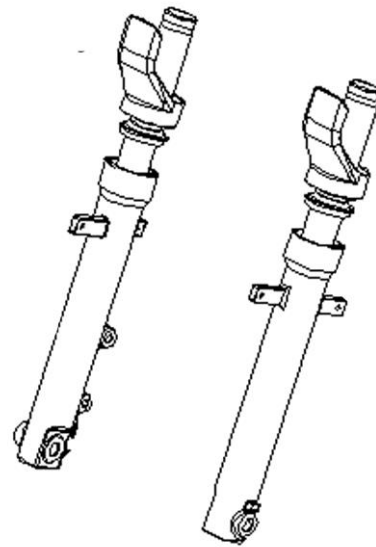

**INSTALLATION**

Install the front shock absorbers onto the steering stem.

Install and tighten the front shock absorber upper mount bolts.

Tighten the lower mount bolts.

\*  
Align the upper mount bolt hole with the groove on the front fork.  
Front shock absorbers are installed at the same altitude.

Install the front wheel.

**STEERING HANDLEBAR**

**REMOVAL**

Remove the throttle seat screws.

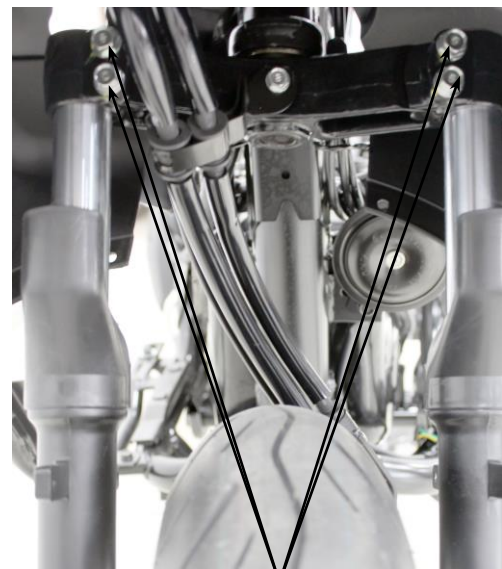

Mount Bolt



Throttle Pipe

# 10. STEERING HANDLEBAR/FRONT WHEEL/ FRONT BRAKE/FRONT SHOCK ABSORBER/FRONT FORK

Remove the throttle seat from the handlebar and disconnect the throttle cable from the throttle pipe. Remove the throttle pipe from the handlebar. Remove two screws and then remove the left handlebar switch.

Remove the upper handlebar cover and the lower cover. (⇒2-5)

Disconnect the brake light switch wire. Remove the front and rear brake master cylinder holder bolts to remove the brake master cylinder.

Remove the steering stem lock bolt, collar, nut and the handlebar.

## STEERING STEM

### REMOVAL

Remove the steering stem lock nut.

**Specia**

Steering Stem Lock Nut Wrench

Lock Nut wrench

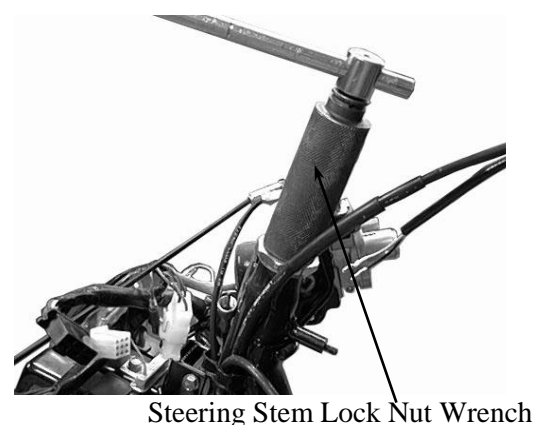
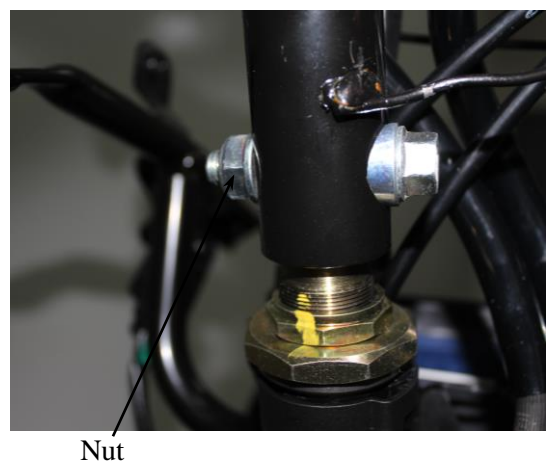
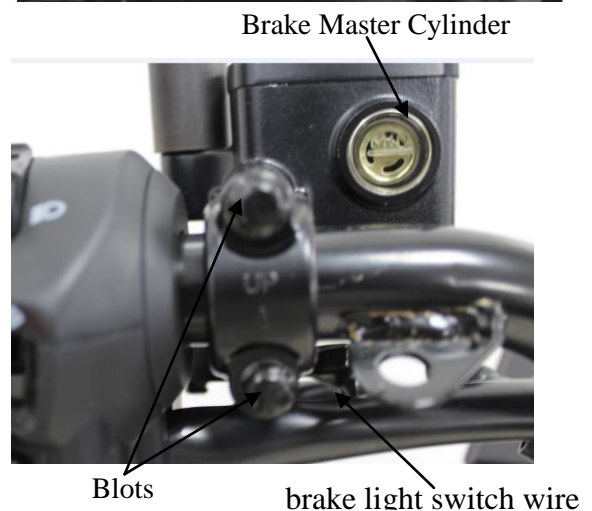
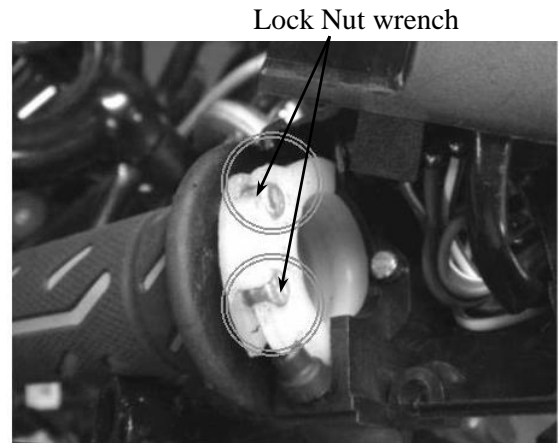

Remove the top cone race.

**\***

- Be careful not to lose the steel balls (20 on top race and 15 on bottom race).
- Clean the openings of frame covers with clean shop towels.

Remove the front fork.

Top Cone Race



### **BOTTOM CONE RACE REPLACEMENT**

Remove the bottom cone race using a chisel.

**\***

- Be careful not to damage the steering stem and front fork.

Drive a new bottom cone race into place with a proper driver.



Bottom Cone Race  
Ball Race Remover

### **BALL RACE REPLACEMENT**

Drive out the top and bottom ball races.

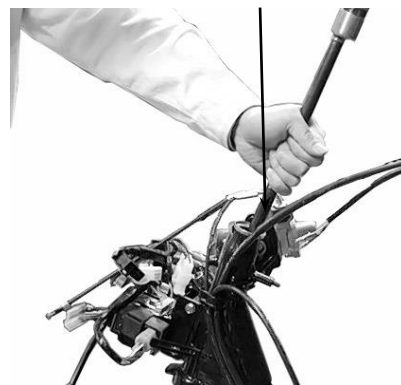

Drive new top and bottom ball races into the steering head using the outer driver.

**Special**

Outer Driver

Outer Driver

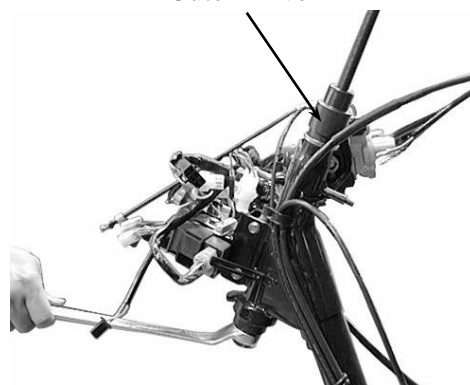



**INSTALLATION**

Install the top and bottom steel balls.

Apply grease to the top and bottom ball races and install 20 steel balls on the top ball race and 15 steel balls on the bottom ball race.

Top Steel Ball



Apply grease to the ball races and install the front fork.

Apply grease to the top cone race and install it. Tighten the top cone race and then turn the steering stem right and left several times to make steel balls contact each other closely.

\* Check that the steering stem rotates freely without vertical play.



Top Cone Race

Top Cone Race Lock Nut Wrench

Install the steering stem lock nut and tighten it while holding the top cone race.

**Torque:** 7.0~8.0kg-m

Install the front wheel.



Steering Stem Lock Nut Wrench

**HANDLEBAR INSTALLATION**

Install the handlebar onto the steering stem tube and then install and tighten the bolt.

**Torque:** 4.5kg-m

Install the front wheel.

Install the brake levers.

Install the handlebar covers.

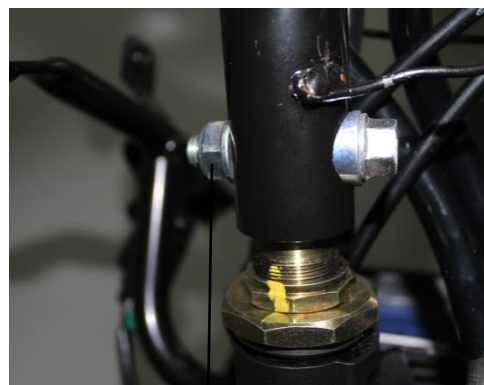

Nut



# 11. REAR WHEEL/REAR BRAKE/REAR SHOCK ABSORBER

---



---

## REAR WHEEL/REAR BRAKE/REAR SHOCK ABSORBER

---

SERVICE INFORMATION.....	11-2
TROUBLESHOOTING .....	11-2
REAR BRAKE.....	11-3
REAR WHEEL .....	11-7
REAR SHOCK ABSORBER.....	11-8

# 11. REAR WHEEL/REAR BRAKE/REAR SHOCK ABSORBER

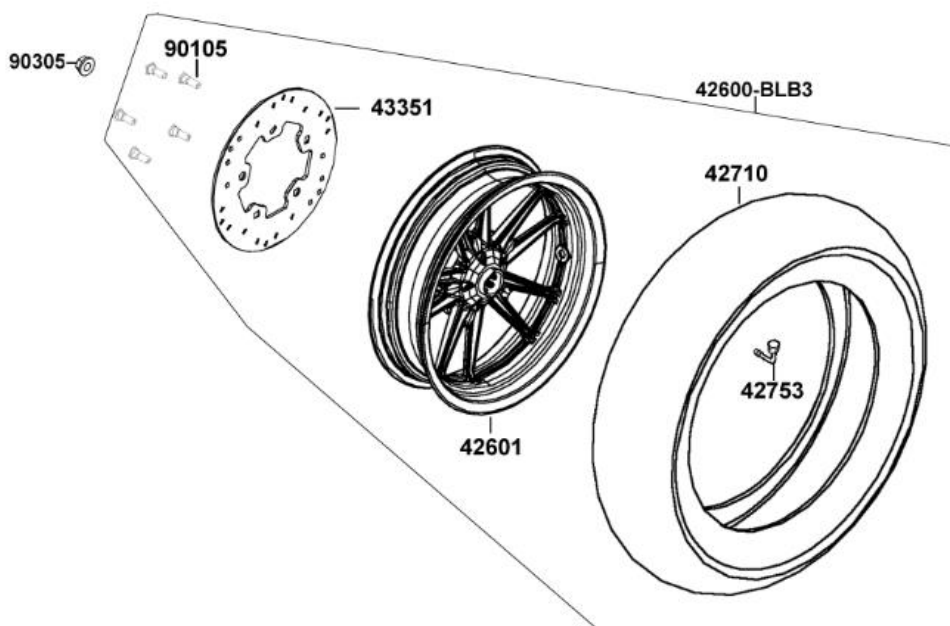
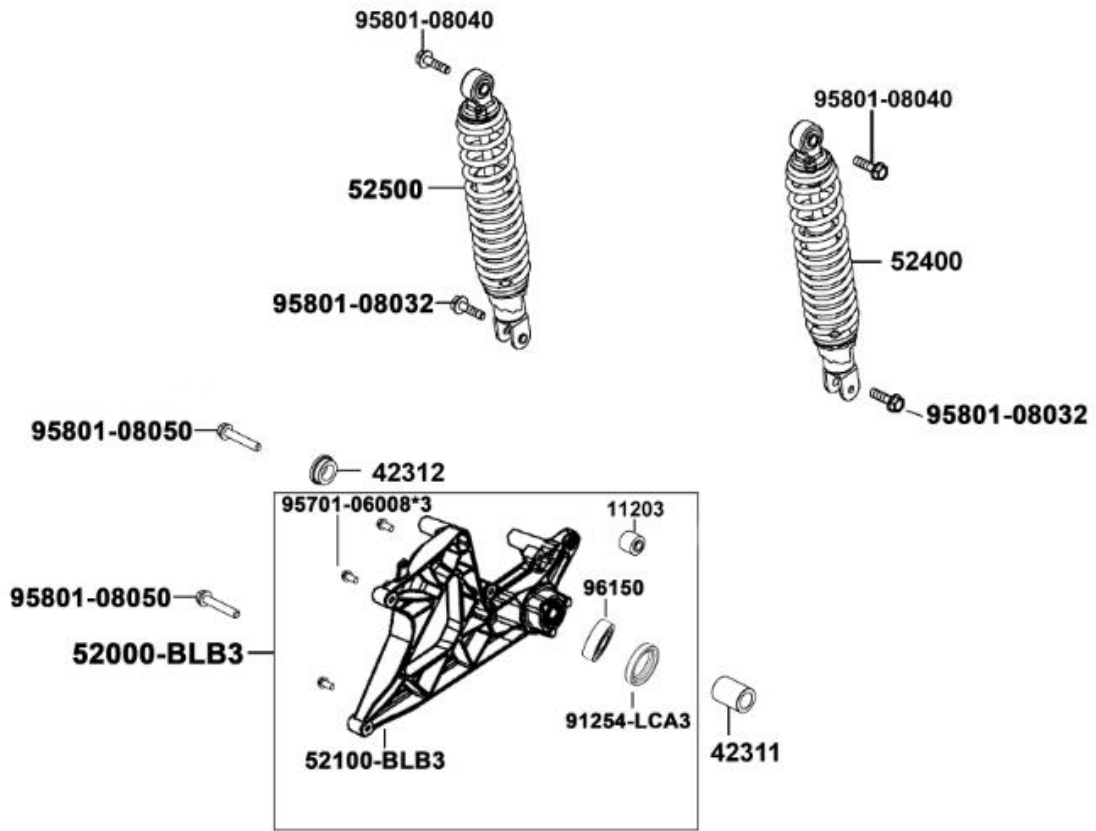

# 11. REAR WHEEL/REAR BRAKE/REAR SHOCK ABSORBER

## SERVICE INFORMATION

### GENERAL

### INSTRUCTIONS

When performing the services stated in this section, the engine and exhaust muffler must be cold to avoid scalding.

During servicing, keep oil or grease off the brake pads and brake disk.

### SPECIFICATIONS

Item	Standard(mm)
Rear wheel rim runout	—
Rear brake disk thickness	4±0.2
Rear brake disk runout	—
brake master cylinder I.D.	12.700~12.743
brake master cylinder piston O.D.	12.657~12.684
Brake caliper piston O.D.	25.33~25.36
Brake caliper cylinder I.D.	25.4~25.45

### TORQUE VALUES

Exhaust muffler lock bolt	35 N-m
Exhaust muffler pipe nut	20 N-m
Rear axle nut	120 N-m
Rear shock absorber lower mount bolt	40 N-m
Rear shock absorber upper mount bolt	40 N-m
Rear brake caliper holder bolt	27 N-m

### TROUBLESHOOTING

#### Rear wheel wobbling

- ◆ Bent rim
- ◆ Faulty tire
- ◆ Axle not tightened properly

#### Soft rear shock absorber

- ◆ Weak shock absorber spring
- ◆ Damper oil leaks

#### Rear wheel noise

- ◆ Worn rear wheel axle bearings
- ◆ Worn rear fork bearings
- ◆ Deformed rear fork

#### Poor brake performance

- ◆ Air in brake system
- ◆ Deteriorated brake fluid
- ◆ Contaminated brake pad surface
- ◆ Worn brake pads
- ◆ Clogged brake fluid line
- ◆ Deformed brake disk
- ◆ Unequal worn brake caliper

# 11. REAR WHEEL/REAR BRAKE/REAR SHOCK ABSORBER

## REAR BRAKE

### REAR BRAKE CALIPER REMOVAL

First remove the exhaust muffler  
Remove the rear brake fluid tube bolt and disconnect the brake fluid tube.  
Remove two bolts attaching the rear brake caliper.  
Remove the rear brake caliper.

When removing the brake fluid tube, use shop towels to cover plastic parts and coated surfaces to avoid damage.

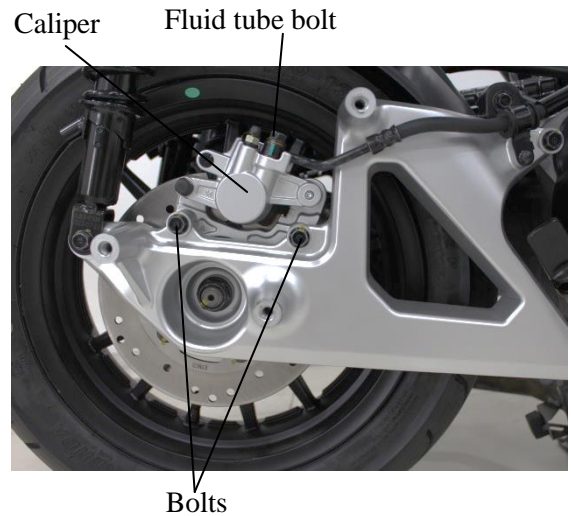

## INSPECTION

Inspect the brake pads and brake disk.

Measure the brake disk thickness.

**Service Limit:** 3.0 mm replace if below

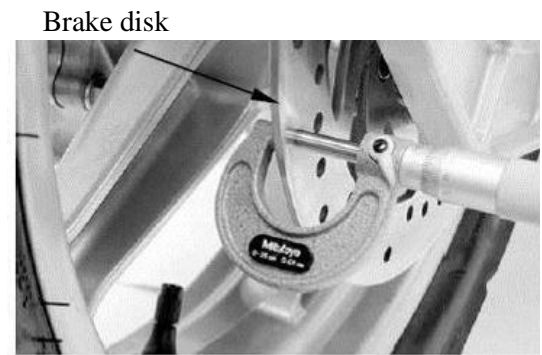

Visually check the brake pad thickness and it should not exceed the wear indicator mark.



## DISASSEMBLY

Remove two brake pads dowel pins and three bolts from the brake caliper.  
Remove the brake pads.



# 11. REAR WHEEL/REAR BRAKE/REAR SHOCK ABSORBER

Remove the piston from the brake caliper.

if necessary, use compressed air to squeeze out the piston through the brake fluid inlet opening and place a towel under the caliper to avoid contamination caused by the removed piston.

Check the piston cylinder for scratches or wear and replace if necessary.

Compressed Air



Push the piston oil seal outward to remove it. Clean the oil seal groove with brake fluid.

Be careful not to damage the piston surface.

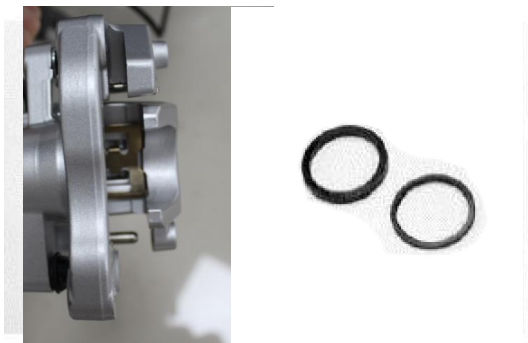

Check the piston for scratches or wear.

Measure the piston O.D. with a micrometer gauge.

**Service Limit:** 25.3 mm

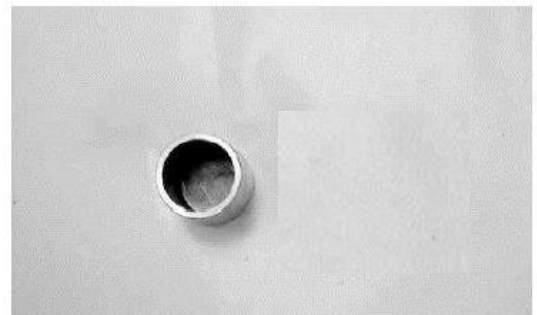

Check the caliper cylinder for scratches or wear and measure the cylinder bore.

**Service Limit:** 25.45 mm





# 11. REAR WHEEL/REAR BRAKE/REAR SHOCK ABSORBER

## ASSEMBLY

Clean all removed parts.  
Apply silicon grease to the piston and oil seal.  
Lubricate the brake caliper cylinder inside wall with brake fluid.  
Install the brake caliper piston with grooved side facing out.

Install the piston with its outer end protruding 3 ~ 5mm beyond the brake caliper.

Install the two spring plates onto the groove of the caliper.

Make sure the spring plate next to the brake pad dowel pin orientation.

Install two brake pads and brake pad dowe pin.

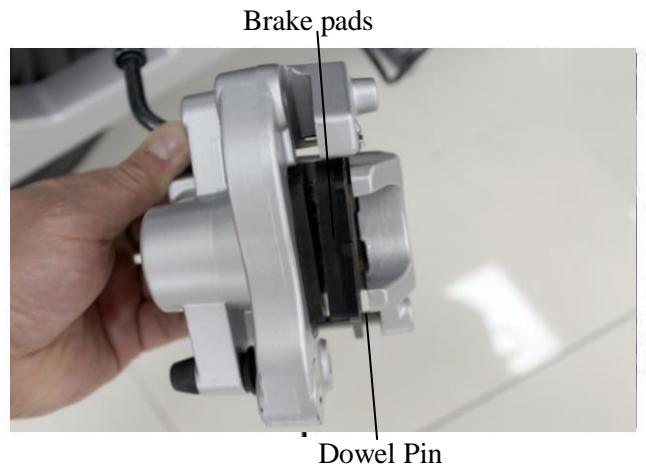
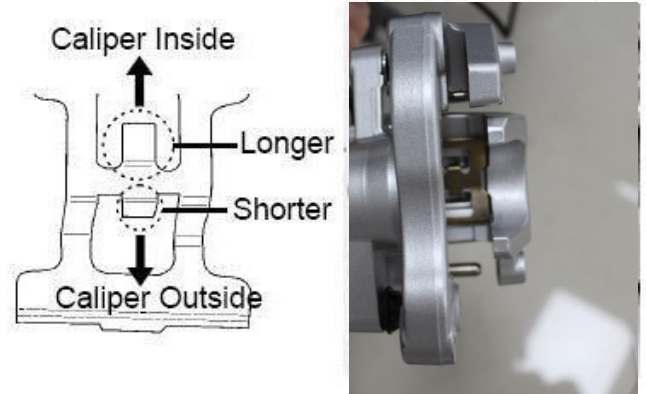
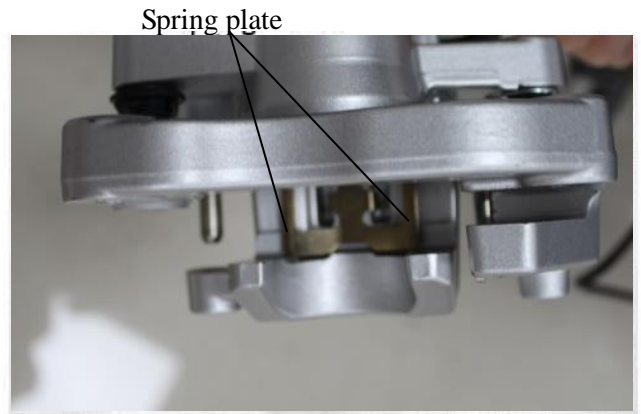
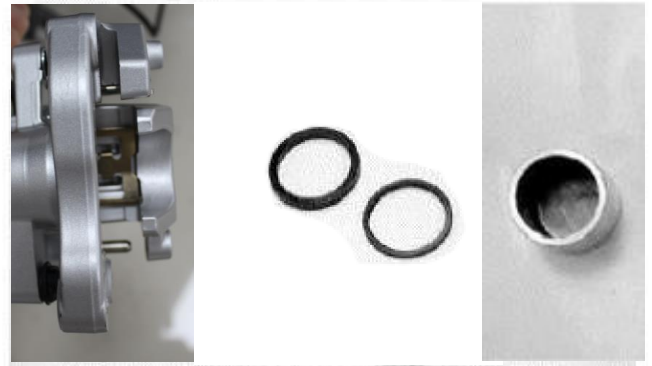

# 11. REAR WHEEL/REAR BRAKE/REAR SHOCK ABSORBER

## INSTALLATION

Install the brake caliper to the rear fork and tighten the two bolts.

Torque: 27 N-m

Connect the brake fluid tube to the brake caliper and install fluid tube bolt, copper washers and tighten the fluid tube bolt.

Fill the brake reservoir with the specified brake fluid and bleed air from the brake system.

When installing the brake fluid tube, be sure to install the two copper sealing washers.

## REAR FORK

### REMOVAL

Remove the exhaust muffler (2-7)

Remove the rear brake caliper

Remove the right rear shock absorber lower mount bolt.

Remove the rear axle nut.

Remove the rear fork.

The installation sequence is the reverse of removal.

Turn the inner race of each bearing with your finger to see if they turn smoothly and quietly.

Also check if the outer race fits tightly in the hub.

Replace the bearings if the race do not turn smoothly, quietly, or if they fit loosely in the hub.

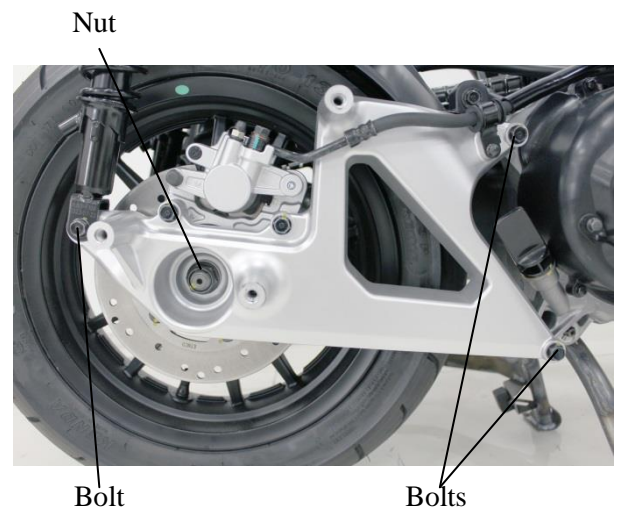
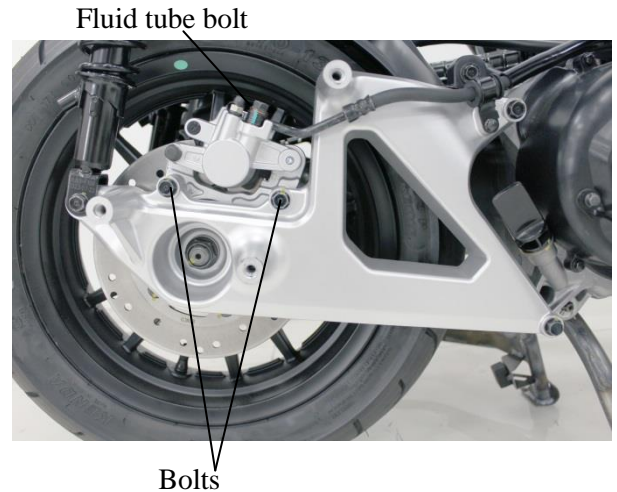

# 11. REAR WHEEL/REAR BRAKE/REAR SHOCK ABSORBER

## REAR WHEEL REMOVAL

- Remove the exhaust muffler
- Remove the rear brake caliper
- Remove the rear fork
- Remove the rear axle collar.
- Remove the rear wheel.

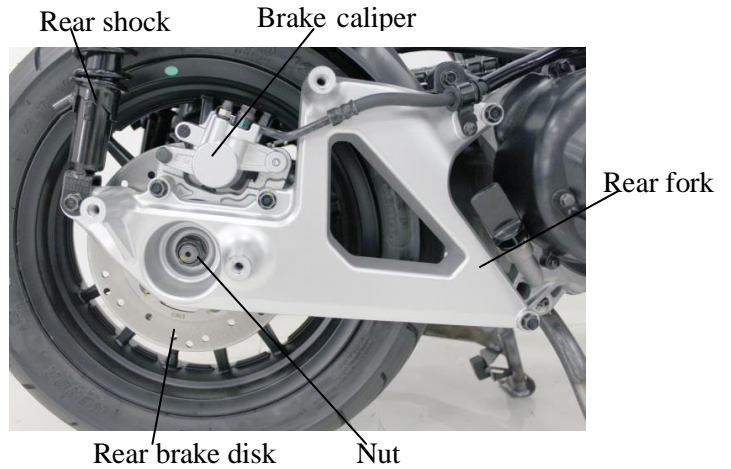

## INSPECTION

Measure the rear wheel rim runout.

### Service Limits:

- Radial:** 2.0mm replace if over
- Axial:** 2.0mm replace if over

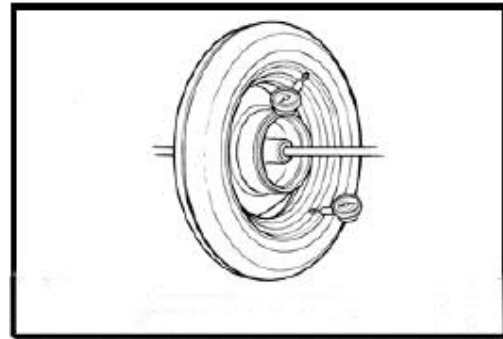

## INSTALLATION

The installation sequence is the reverse of removal.

### Torque:

- Rear shock absorber lower mount bolt: 35-45N-m
- Rear axle nut: 120 N-m

# 11. REAR WHEEL/REAR BRAKE/REAR SHOCK ABSORBER

## REAR SHOCK ABSORBER

### REMOVAL

Remove the met-in box.  
Remove the body cover.  
Remove the air cleaner case.  
Remove the rear shock absorber upper and lower mount bolts to remove the rear shock absorber.

### INSTALLATION

Install the rear shock absorber.  
Install the rear shock absorber upper mount bolt and then install the lower mount bolt.

#### Torque:

**Upper Mount Bolt:** 3.5~4.5kg-m

**Lower Mount Bolt:** 2.4~3.0kg-m

Install the frame body cover.

Upper Mount Bolts



Lower Mount Bolts

Rear left Shock absorber

Upper Mount Bolts



Rear Right Shock absorber

Lower Mount Bolts

# 12. BATTERY/CHARGING SYSTEM

---

---

---

---

**12**

---

---

## BATTERY/CHARGING SYSTEM

---

CHARGING SYSTEM LAYOUT .....	12-1
CHARGING CIRCUIT .....	12-1
SERVICE INFORMATION.....	12-2
TROUBLESHOOTING.....	12-3
BATTERY CHARGING .....	12-5
REGULATOR/RECTIFIER .....	12-6



# 12. BATTERY/CHARGING SYSTEM

## CHARGING SYSTEM LAYOUT

Regulator/Rectifier



AC Generator

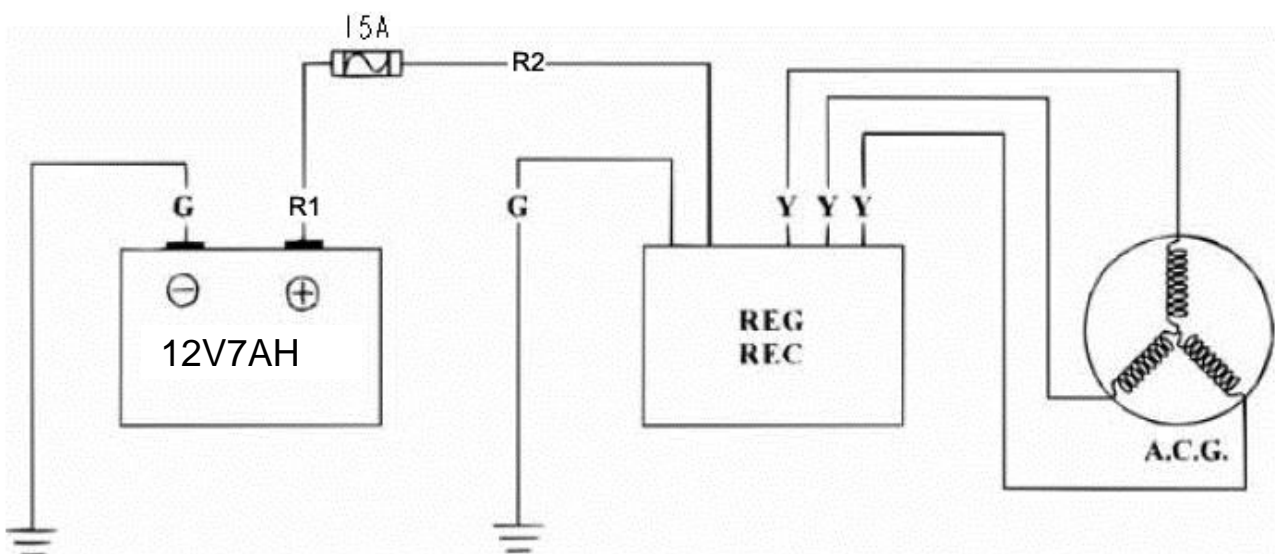

## 12. BATTERY/CHARGING SYSTEM

### SERVICE INFORMATION

#### GENERAL INSTRUCTIONS

\*

The battery electrolyte (sulfuric acid) is poisonous and may seriously damage the skin and eyes. Avoid contact with skin, eyes, or clothing. In case of contact, flush with water and get prompt medical attention

- The battery can be charged and discharged repeatedly. If a discharged battery is not used for a long time, its service life will be shortened. Generally, the capacity of a battery will decrease after it is used for 2~3 years. A capacity-decreased battery will resume its voltage after it is recharged but its voltage decreases suddenly and then increases when a load is added.
- When a battery is overcharged, some symptoms can be found. If there is a short circuit inside the battery, no voltage is produced on the battery terminals. If the rectifier won't operate, the voltage will become too high and shorten the battery service life.
- If a battery is not used for a long time, it will discharge by itself and should be recharged every 3 months.
- A new battery filled with electrolyte will generate voltage within a certain time and it should be recharged when the capacity is insufficient. Recharging a new battery will prolong its service life.
- Inspect the charging system according to the sequence specified in the Troubleshooting.
- Do not disconnect and soon reconnect the power of any electrical equipment because the electronic parts in the regulator/rectifier will be damaged. Turn off the ignition switch before operation.
- It is not necessary to check the MF battery electrolyte or fill with distilled water.
- Check the load of the whole charging system.
- Do not quick charge the battery. Quick charging should only be done in an emergency.
- Remove the battery from the motorcycle for charging.
- When replacing the battery, do not use a traditional battery.
- When charging, check the voltage with an electric tester.

#### SPECIFICATIONS

Item		Standard	
Battery	Capacity	12V7AH	
	Voltage (20°C)	Fully charged	12.8V
		Insufficient charged	< 12V
	Charging current	0.6A* 5~10H	

## 12. BATTERY/CHARGING SYSTEM

---

### TROUBLESHOOTING

#### No power

- Dead battery
- Disconnected battery cable
- Fuse burned out
- Faulty ignition switch

#### Low power

- Weak battery
- Loose battery connection
- Charging system failure
- Faulty regulator/rectifier

#### Intermittent power

- Loose battery cable connection
- Loose charging system connection
- Loose connection or short circuit in ignition system

#### Charging system failure

- Loose, broken or shorted wire or connector
- Faulty regulator/rectifier
- Faulty A.C. generator

## 12. BATTERY/CHARGING SYSTEM

### BATTERY REMOVAL

Remove the battery cover.  
Disconnect the battery cables .

- \* First disconnect the battery negative (-) cable and then the positive (+) cable.

Remove the battery.  
The installation sequence is the reverse of removal.

### BATTERY CHARGING (OPEN CIRCUIT VOLTAGE) INSPECTION

Remove the battery cover and disconnect the battery cables.

Measure the voltage between the battery terminals.

Fully charged : 13.0V ~ 13.2V

Undercharged : 12.3V max.

- \* Battery charging inspection must be performed with an electric tester.

### CHARGING METHOD

Connect the charger positive (+) cable to the battery positive (+) cable.

Connect the charger negative (-) cable to the battery negative (-) cable.

- \* 
  - Keep flames and sparks away from a charging battery.
  - Turn power ON/OFF at the charger, not at the battery terminals to prevent sparks near the battery.
  - Charge the battery according to the current specified on the battery surface.

Charging current :Standard: 0.6A  
Quick: 3A

Charging time: Standard: 5~10 hours  
Quick: 1.0 hours

After charging: Open circuit voltage: 12.8V min.

- \* 
  - Quick charging should only be done in an emergency.
  - During quick charging, the battery temperature should not exceed 45°C.
  - Measure the voltage 30 minutes after the battery is charged.

Regulator/Rectifier



Battery

Black

Red

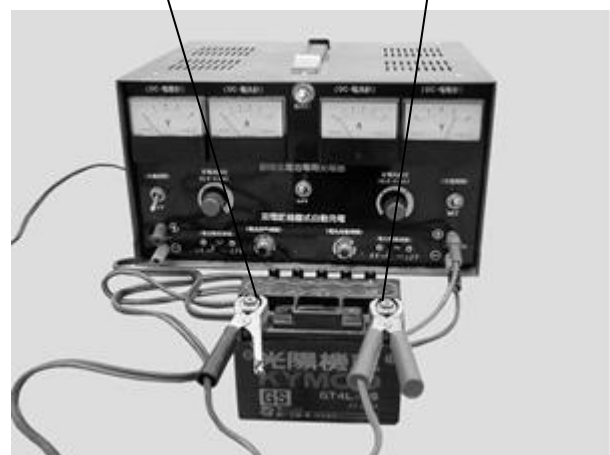

## 12. BATTERY/CHARGING SYSTEM

### PERFORMANCE TEST

Warm up the engine.

Remove the floor mat and front tool box cover.

\* Use a fully charged battery to check the charging system output.

Stop the engine and open the fuse box.

Disconnect the wire lead from the fuse terminal.

Connect an ammeter between the wire lead and fuse terminal as shown.

Connect the battery positive (+) terminal to the voltmeter positive (+) probe and battery negative (-) terminal to the voltmeter negative (-) probe.

Start the engine, gradually increase engine speed to test the output:

Position RPM	Day	Night
2500	1.3A min.	1.0A min.
6000	2.0A min.	2.0A min.

**Charging Limit Voltage:**  $14 \pm 0.5V/5500rpm$

If the limit voltage is not within the specified range, check the regulator/ rectifier.

### A.C GENERATOR INSPECTION

This test can be made without removing the Stator from the engine. Disconnect the yellow wire from the auto-by starter.

Remove the met-in box.

Disconnect the A.C. generator connector.

Check the continuity between the yellow wires and ground.

There should be continuity between the yellow wires and on continuity between each yellow wire and ground.

**Resistance:**

Yellow ~ Yellow	1~2.5Ω
-----------------	--------

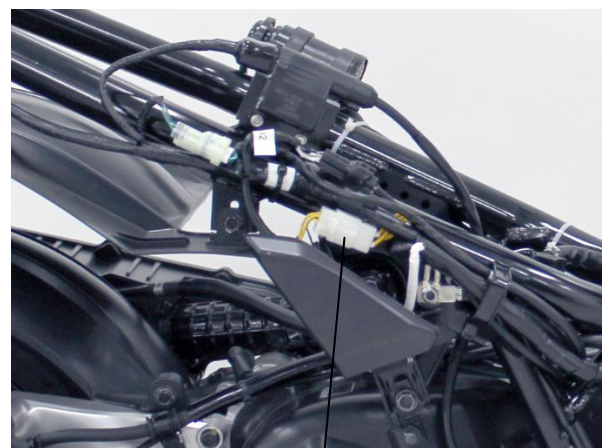
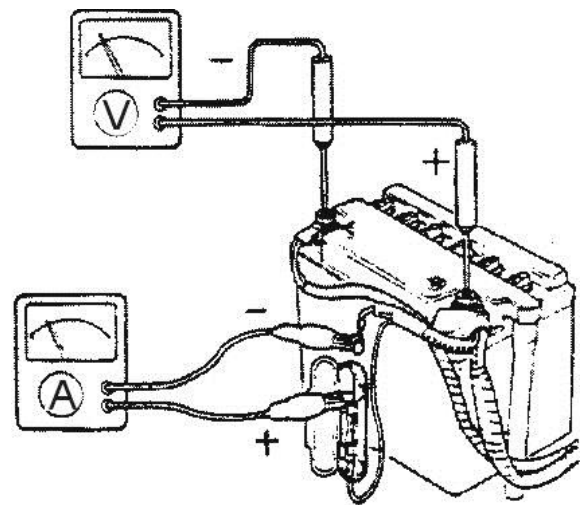

A.C. Generator Connector





# 12. BATTERY/CHARGING SYSTEM

## A.C.GENERATOR REMOVAL

A.C. generator removal

A.C. generator installation

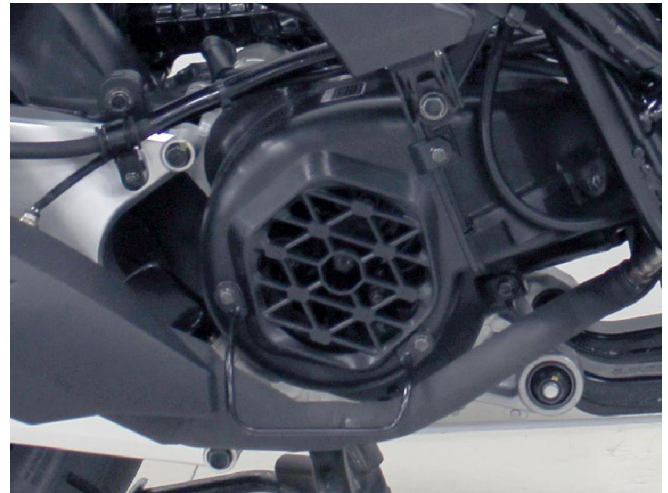

## REGULATOR/RECTIFIER INSPECTION

Remove the met-in box.

Remove the regulator/rectifier wire coupler.

Check the continuity between the wire terminals.

Normal Direction: Continuity

	(+)Probe	(-)Probe
I	Yellow	Green
II	Red	Yellow

Reverse Direction: No Continuity

	(+)Probe	(-)Probe
I	Green	Yellow
II	Yellow	Red



Regulator/Rectifier

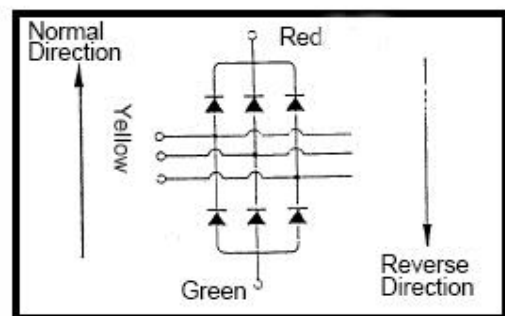

## VOLTAGE REGULATION TEST

Connect a volt meter across the battery terminals.

Start the engine and gradually increase the engine speed to 5500 rpm.

The battery terminal voltage should be within 13.5v~14.5V.

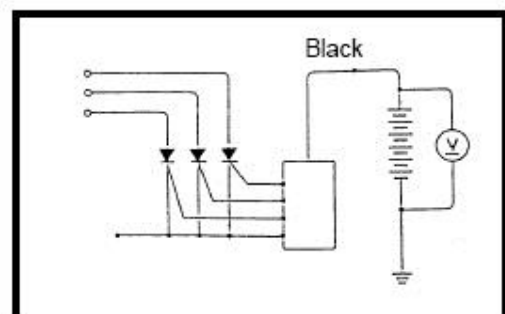

# **13. IGNITION SYSTEM**

---

---

## **IGNITION SYSTEM**

---

<b>IGNITION SYSTEM LAYOUT</b> .....	<b>13-1</b>
<b>SERVICE INFORMATION</b> .....	<b>13-2</b>
<b>TROUBLESHOOTING</b> .....	<b>13-2</b>
<b>SPARK PLUG</b> .....	<b>13-3</b>
<b>IGNITION COIL INSPECTION</b> .....	<b>13-3</b>
<b>A.C. GENERATOR INSPECTION</b> .....	<b>13-4</b>

# 13. IGNITION SYSTEM

## IGNITION SYSTEM LAYOUT

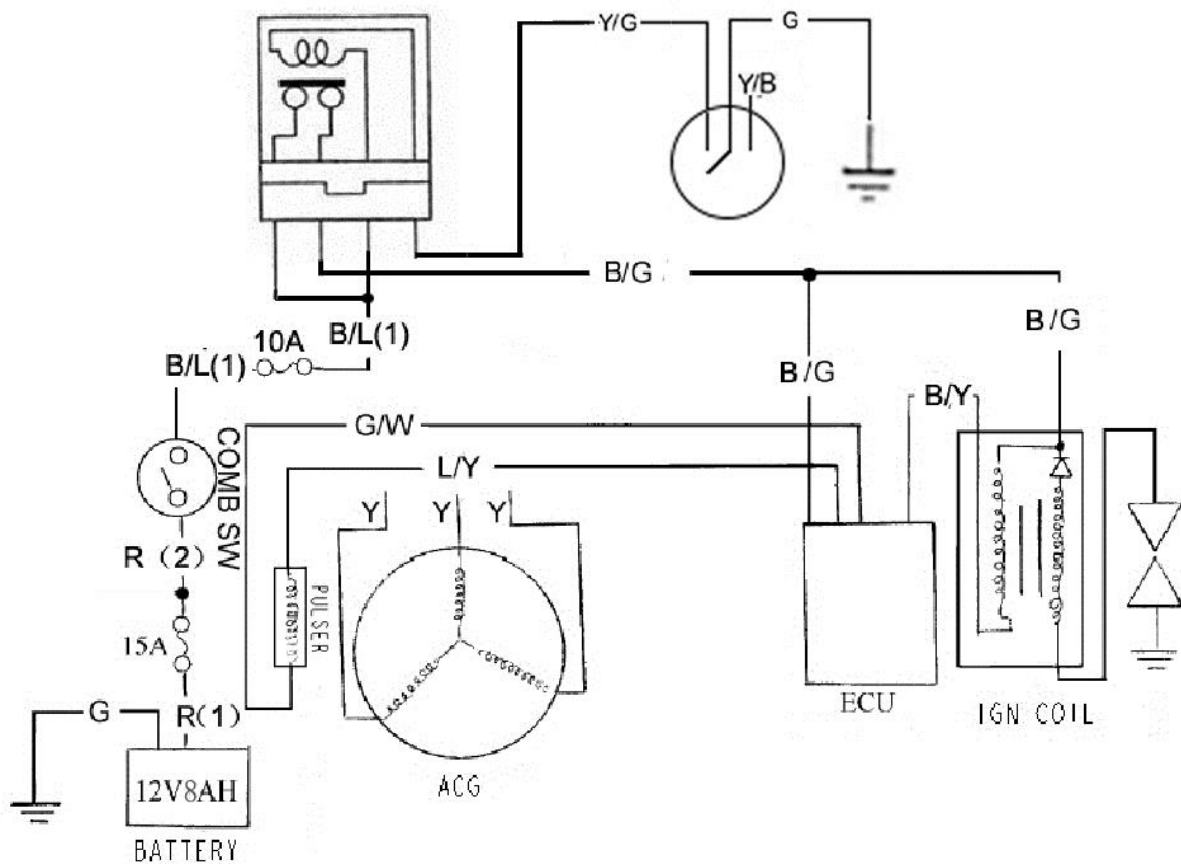
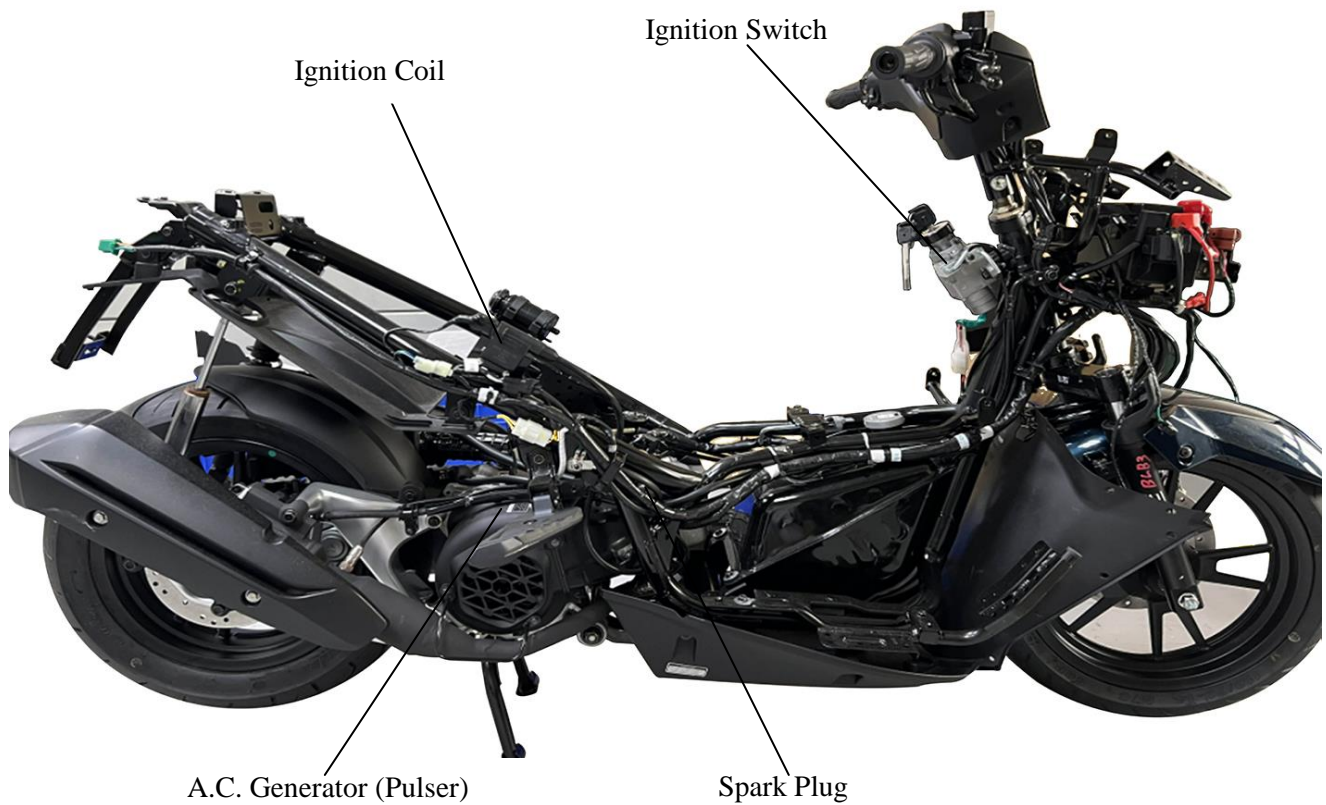

# 13. IGNITION SYSTEM

## SERVICE INFORMATION

### GENERAL INSTRUCTIONS

- Some electrical components may be damaged if terminals or connectors are connected or disconnected while the ignition switch is “ON” and current is present.
- When servicing the ignition system, always follow the steps in the troubleshooting on page 17-2.
- The ignition timing cannot be adjusted since the ignition control module is already adjusted in factory.
- The ignition control module or ECU maybe damaged if dropped or the connector is disconnected when the key is “ ON ”, the excessive voltage may damage the ignition control module or ECU. Always turn off the ignition switch before servicing.
- A faulty ignition system is often related to poor connections. Check those connections before proceeding.
- Make sure the battery is adequately charged. Using the starter motor with weak battery results in a slower engine cranking speed as well as no spark at the spark plug.
- Use a spark plug of the correct heat range. Using spark plug with an incorrect heat range can damage the engine.

### SPECIFICATIONS

Item		Standard
Spark plug	Standard type	NGK LR7D
Spark plug gap		0.6 ~ 0.7 mm
Inductive Ignition Coil	Primary coil	0.60~0.66Ω
Throttle Position Sensor Input Volt		5V ±0.1
Fuel Injector		12 ±0.6Ω
Engine Temperature Sensor		11.529 ±10% kΩ(25°C)
Oxygen Sensor ( engine warming condition )		15Ω
Crank Position Sensor		96~144Ω

### TROUBLESHOOTING

#### No peak voltage

- Short circuit in engine stop switch or ignition switch wire.
- Faulty engine stop switch or ignition switch.
- Loose or poorly connected ignition control module connectors.
- Open circuit or poor connection in ground wire of the ignition control module.
- Faulty crank position sensor.
- Faulty ignition control module.

#### Peak voltage is normal, but no spark jumps at the plug

- Faulty spark plug or leaking ignition coil secondary current.
- Faulty ignition coil.

## **13. IGNITION SYSTEM**

### **IGNITION COIL INSPECTION**

Remove the seat and met-in box.

Remove the ignition coil.

### **IGNITION COIL CONTINUITY**

#### **TEST**

Inspect the continuity of the ignition coil, primary coil

Measure the ignition coil resistances

0.60~0.66Ω/20℃

Ignition Coil

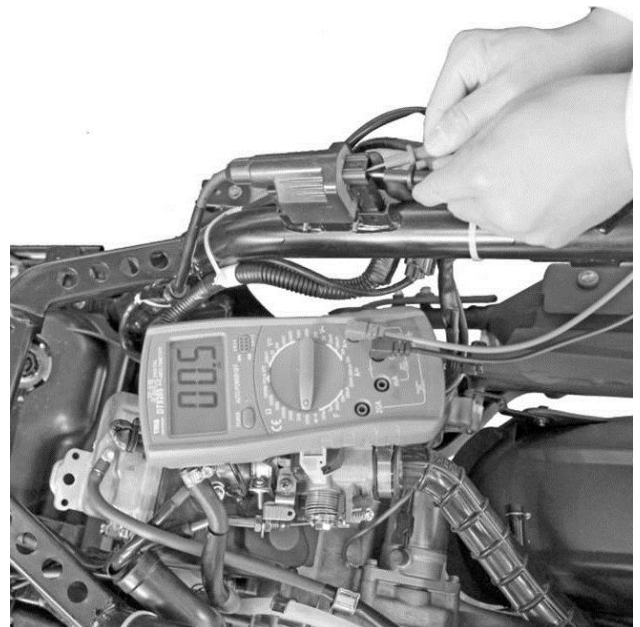
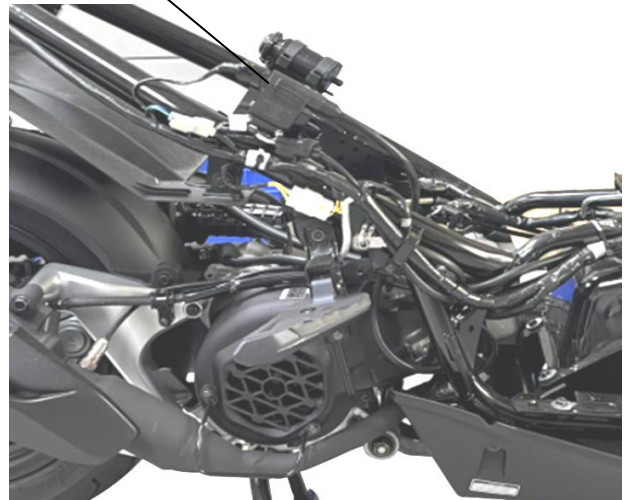



## 13. IGNITION SYSTEM

### CRANK POSITION SENSOR INSPECTION

This test is performed with the stator installed in the engine

Remove the seat and met-in box.

Disconnect the Crank Position Sensor Wire Coupler.

Measure the resistance between the blue/white and green/white wire terminals.

Blue/Yellow~ Green/White	96Ω-144Ω
--------------------------	----------

Crank Position Sensor Coupler.

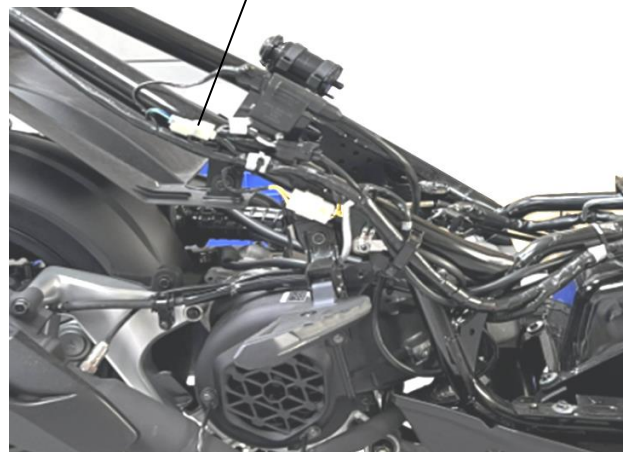

# 14. STARTING SYSTEM

---

---

## STARTING SYSTEM

---

STARTING SYSTEM LAYOUT-----	14-1
SERVICE INFORMATION -----	14-2
TROUBLESHOOTING-----	14-2
STARTER MOTOR-----	14-3
STARTER RELAY INSPECTION-----	14-4

# 14. STARTING SYSTEM

## STARTING SYSTEM LAYOUT

Starter Relay①



Starter Motor

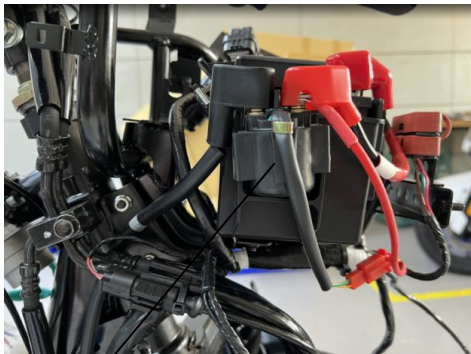

Starter Relay②

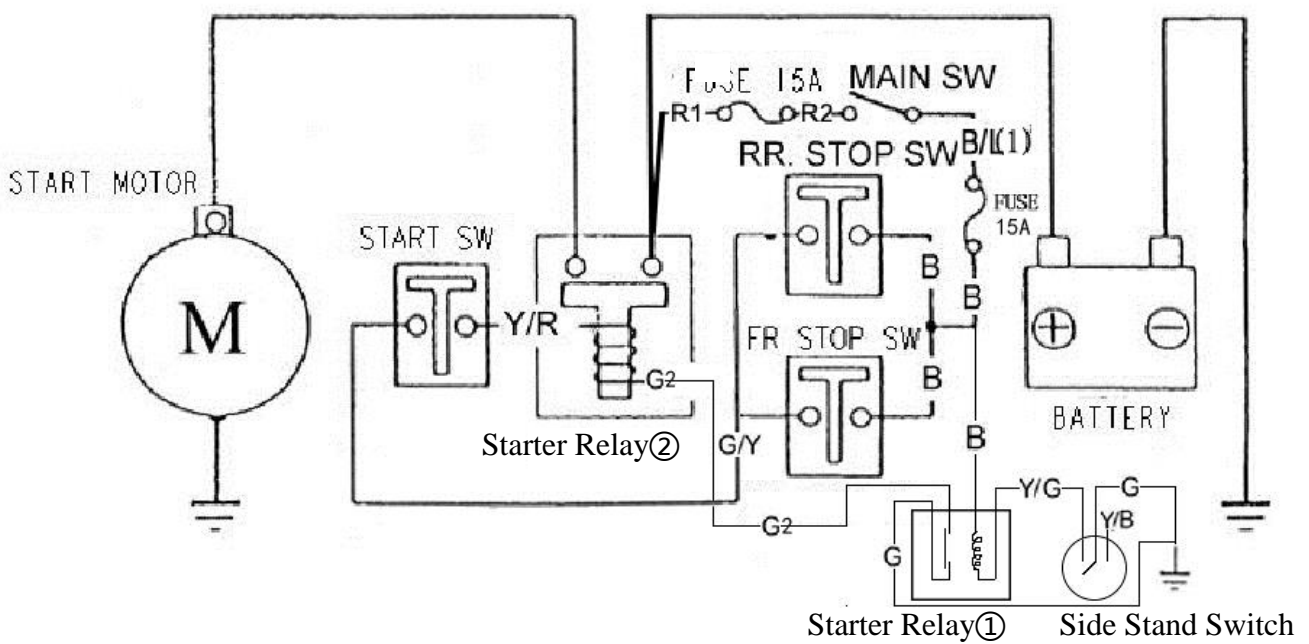

# 14. STARTING SYSTEM

---

## SERVICE INFORMATION

### GENERAL INSTRUCTIONS

- The removal of starter motor can be accomplished with the engine installed.
- After the starter clutch is installed, be sure to add the engine oil and coolant and then bleed air from the cooling system.

### TORQUE VALUES

Starter motor mounting bolt	6.7~10.8	N-m
Starter motor case screw	2.9~4.9	N-m
Starter clutch bolt	9.8~13.7	N-m

### SPECIAL TOOLS

Flywheel puller	A120E00002
-----------------	------------

### TROUBLESHOOTING

#### Starter motor won't turn

- Fuse burned out
- Weak battery
- Faulty ignition switch
- Faulty starter clutch
- Faulty front or rear stop switch
- Faulty starter relay
- Poorly connected, broken or shorted wire
- Faulty starter motor

#### Lack of power

- Weak battery
- Loosed wire or connection
- Foreign matter stuck in starter motor or gear

#### Starter motor rotates but engine does not start

- Faulty starter pinion
- Starter motor rotates reversely
- Weak battery

## 14. STARTING SYSTEM

### STARTER MOTOR

#### REMOVAL

Unlock the seat with the ignition key.  
 Open the seat.  
 Remove 4 bolts attaching the met-in box.  
 Remove the met-in box .  
 Turn the ignition switch to "OFF".

Release the rubber cap and remove the terminal nut to disconnect the cable from the start motor.

Remove the two mounting bolts then remove the start motor.

#### INSPECTION

Connect the start motor cable directly to the battery positive terminal.  
 If the start motor does not turn, the starter motor is faulty.

#### INSTALLATION

Coat a new O-ring (91309) with engine oil and install it into the start motor groove.  
 Install the starter motor into the crankcase.  
 Install the two mounting bolts securely.

#### **TORQUE: 0.7~1.1 kgf-m**

Connect the cable to motor terminal with the terminal screw and tighten it securely.

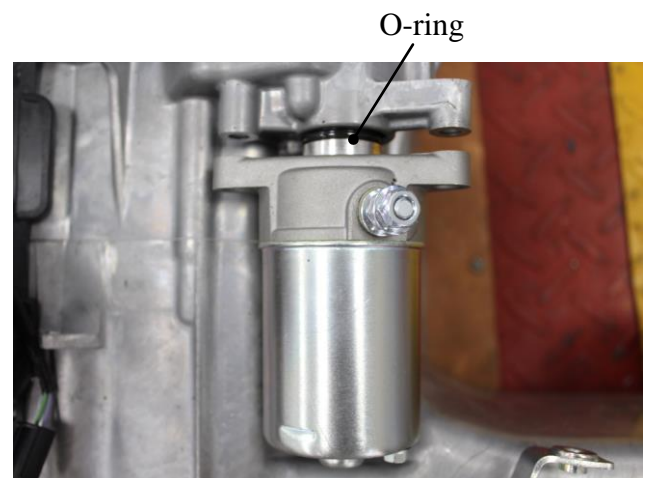
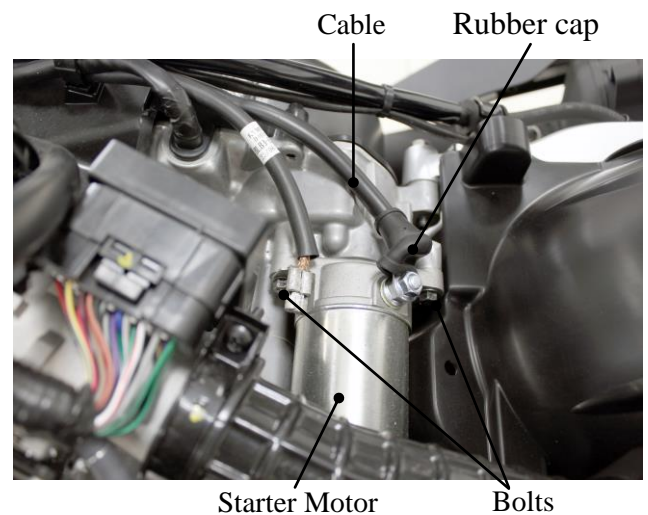



## 14. STARTING SYSTEM

### STARTER RELAY②

#### REMOVAL

Remove the front cover.

Disconnect the starter relay wire connector.  
Release the rubber caps and remove the nuts, then disconnect the start motor cable, battery positive cable and harness wire.  
Remove the starter relay.

#### INSTALLATION

Install the starter relay.

Connect the connector and cables. Tighten the nuts to the specified torque.

**TORQUE: 3.0 kgf-m**

\* If the nuts are not tightened with the specified torque, the starter relay may be damaged and fail starting.

#### INSPECTION

##### Continuity Test

Disconnect the starter relay wire connector.

Check for continuity between the yellow/red wire and green/yellow wire. There should be continuity when the starter button is depressed. If there is no continuity, check the starter button for continuity and inspect the wire.

##### Operation Test (On Board)

Turn on the ignition switch.  
Squeeze the brake lever and press the start button at the same time.  
The engine should be started and the starter relay will emit a click sound.

##### No click sound:

- Check the starter relay voltage
- Check the grounding circuit
- Check the starter relay operation

Starter Relay

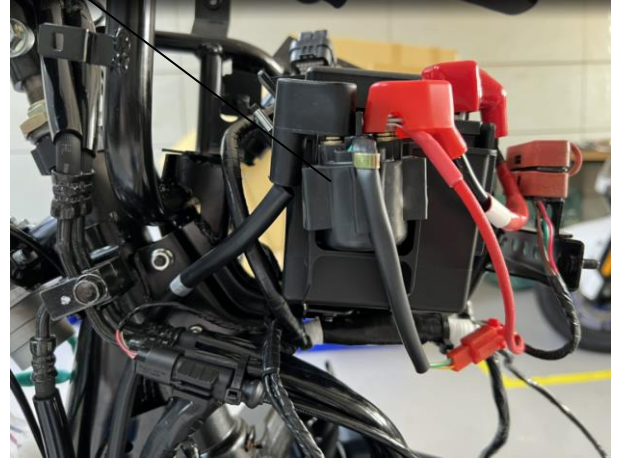

Green/Yellow Wire

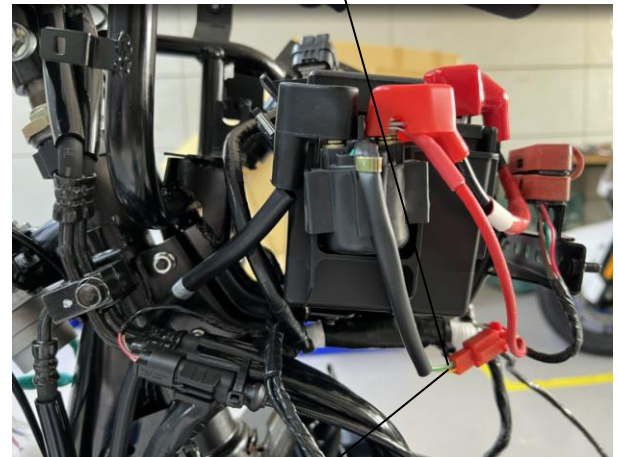

Yellow/Red Wire

## 14. STARTING SYSTEM

---

### Starter Relay② Voltage

Turn on the ignition switch.

Use a multimeter to measure the voltage. One probe touch the Y/R wire the other touch the ground.

The measurement result will be close to the battery voltage

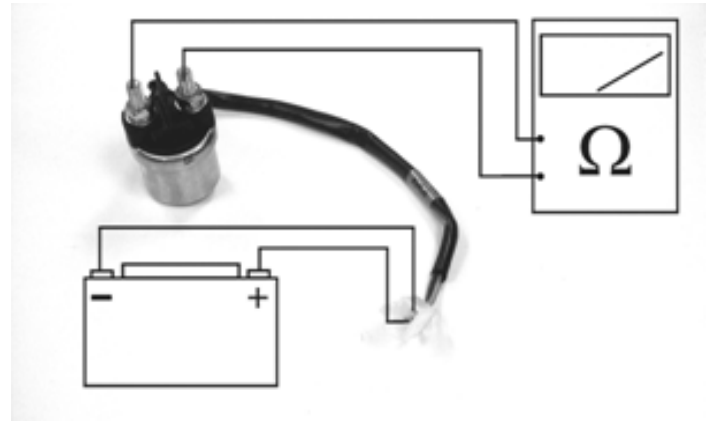

### Grounding Circuit

Disconnect the connector.

Check the continuity between the green wire and the frame.

There should be continuity always.

### Operation Test (Removed)

Connect the electric meter to the starter relay terminals that connect to the battery positive cable and the starter motor cable. Connect a fully charged battery across the starter relay yellow/red and green/yellow wire terminals.

Check for continuity between the starter relay large terminals.

The relay is normal if there is continuity and it emits click sound.

\* Do not apply the battery voltage jump for more than five seconds or the relay may be damaged.

## 14. STARTING SYSTEM

### Starter Relay①

#### INSPECTION

Remove the Starter Relay①.  
Connect the ohmmeter to Starter Relay① connector terminals.

#### Connection: Black – Yellow/Green

Connect 12 V battery with the Starter Relay① connector.

#### Connection: Green –Green

There should be continuity only when 12 V battery connected.  
If there should not be continuity always, replace a Starter Relay①.

#### REMOVAL

Disconnect the Starter Relay① connector and remove it from frame.

Starter Relay①

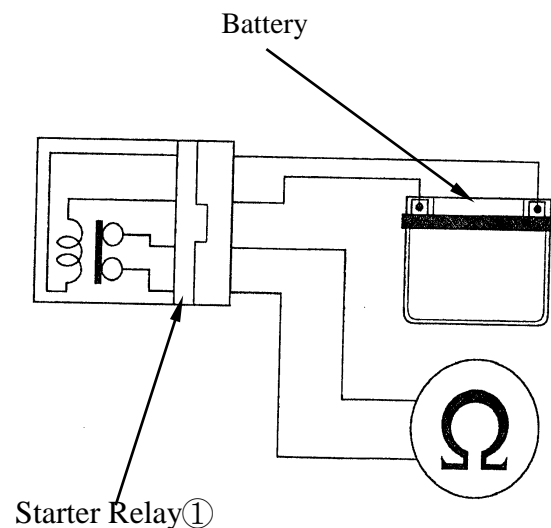

# **15. INSTRUMENT/SWITCHES/LIGHTS**

---

---

---

---

---

---

---

---

---

## **INSTRUMENT/SWITCHES/LIGHTS**

---

SERVICE INFORMATION .....	15-1
TROUBLESHOOTING .....	15-1
FUEL UNIT .....	15-2
SWITCHES.....	15-4
STOP SWITCH INSPECTION/HORN .....	15-6
INSTRUMENT/HEADLIGHT .....	15-8

## **15. INSTRUMENT/SWITCHES/LIGHTS**

---

### **SERVICE INFORMATION**

#### **GENERAL INSTRUCTIONS**

- Wires should be connected to other wires of the same color. Couplers must be connected to other couplers of the same color.
- All plastic plugs have locking tabs that must be released before disconnecting, and must be aligned when reconnecting.
- After installation of each switch, a continuity check must be performed.

#### **TROUBLESHOOTING**

##### **Lights do not come on when ignition switch is “ON”**

- Burned bulb
- Faulty switch
- Broken or shorted wire
- Fuse burned out
- Weak battery
- Poorly connected wire
- Faulty winker

##### **Light dims**

- Faulty ignition coil
- Wire or switch resistance too high
- Faulty regulator/rectifier

##### **Headlight does not change when dimmer switch is turn to Hi or Lo**

- Faulty or burned bulb
- Faulty dimmer switch

##### **Motor oil indicator light does not come on (when motor oil is insufficient)**

- Fuse burned out
- Dead battery
- Faulty ignition switch
- Faulty instrument
- Faulty oil meter

##### **Motor oil indicator light winks**

- Loose wire connection
- Broken wire
- Faulty oil meter

##### **Fuel gauge pointer does not register correctly**

- Disconnected wire or connector
- Broken wire
- Faulty float
- Faulty fuel unit
- Faulty instrument

##### **Fuel gauge pointer fluctuates or swings**

- Loose wire connection
- Faulty fuel unit
- Faulty instrument



# 15. INSTRUMENT/SWITCHES/LIGHTS

## FUEL UNIT

\* No Smoking!

### REMOVAL

Remove the seat.  
Open the fuel tank cover.  
Remove the center cover.  
Remove the bracket of the fuel tank cover lock.

Disconnect the fuel Pump/unit wire connectors.

\* Do not damage the fuel unit wire.

Remove the fuel pump/Unit.

\* Be careful not to bend or damage the fuel unit float arm.

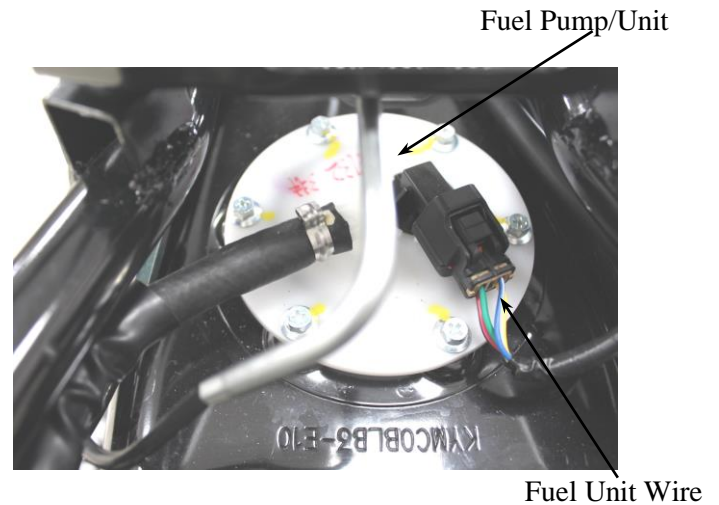

### INSPECTION

Remove the fuel unit.  
Measure the resistance between the fuel unit wire terminals with the float at upper and lower positions.

RESISTANCES Unit: Ω

Wire Terminals	Upper	Lower
L/W~Y/W	100±3%Ω	1100±3%Ω

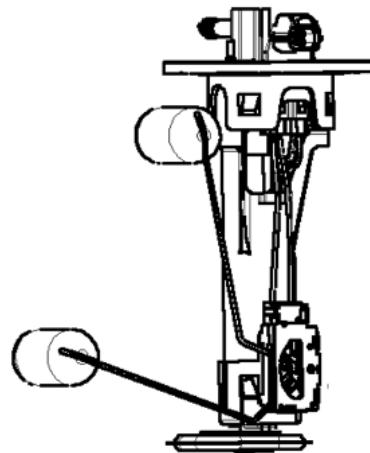

### FUEL GAUGE INSPECTION

Connect the fuel unit wire connectors and turn the ignition switch "ON".

\* Before performing the following test, operate the turn signals to determine that the battery circuit is normal.

Check the fuel gauge needle for correct indication by moving the fuel unit float up and down.

Float Position	Needle Position
Upper	"F" (Full)
Lower	"E" (Empty)



## 15. INSTRUMENT/SWITCHES/LIGHTS

### INSTALLATION

The installation sequence is the reverse of removal.

\*

- Install the fuel unit at the connect position.



### BRAKE LIGHT SWITCH

Remove the upper handlebar cover.

Disconnect front or rear brake light switch connectors and check for continuity between the switch terminals.

There should be continuity with the front or rear brake lever squeezed, and there should be no continuity with the front or rear brake lever is released.



Front Brake Light Switch

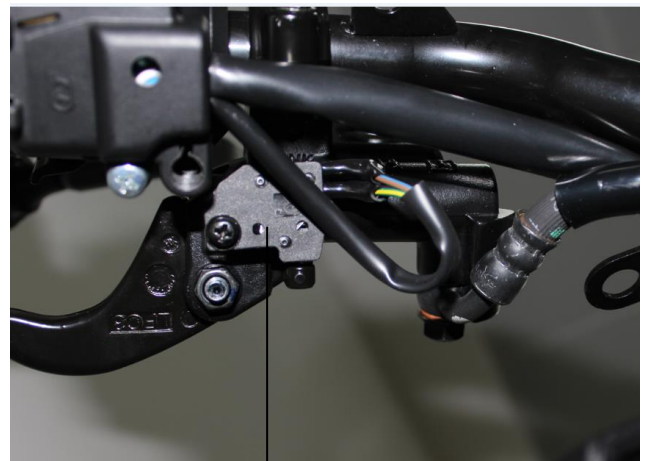

Rear Brake Light Switch

# 15. INSTRUMENT/SWITCHES/LIGHTS

## IGNITION SWITCH

### INSPECTION

Remove the front cover.

Disconnect the ignition switch connector and check the ignition switch for continuity at the switch side connector terminals.

Continuity should exist between the color code wires as follows:

	IG	E1.E2	BAT1	BAT2
ON			○—○	
OFF	○—○	○—○		
LOCK	○—○	○—○		
CORD COLOR	B/W	G	R	B

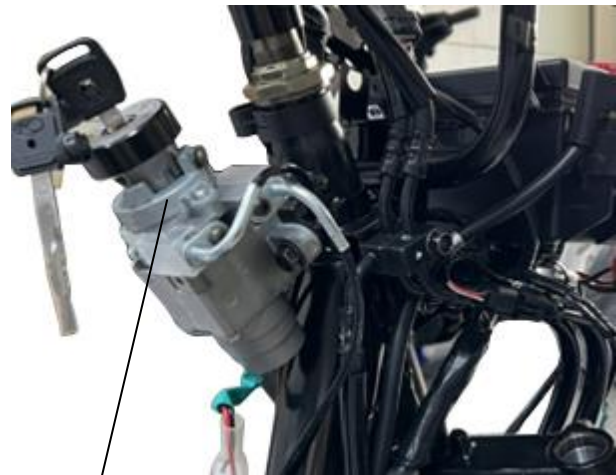

Ignition switch

## RIGHT HANDLEBAR SWITCH

### INSPECTION

Remove the up and down handlebar cover.

Disconnect the left handlebar switch connector and check for continuity at switch side connector terminals.

Continuity should exist between the color code wires as follows:

START SW		
	ST	E
FREE		
PUSH	○—○	○—○
CORD COLOR	Y/R	G



Starter Switch

# 15. INSTRUMENT/SWITCHES/LIGHTS

## LEFT HANDLEBAR SWITCH INSPECTION

Remove the up and down handlebar cover.

Disconnect the right handlebar switch connector and check for continuity at switch side connector terminals.

Continuity should exist between the color code wires as follows:

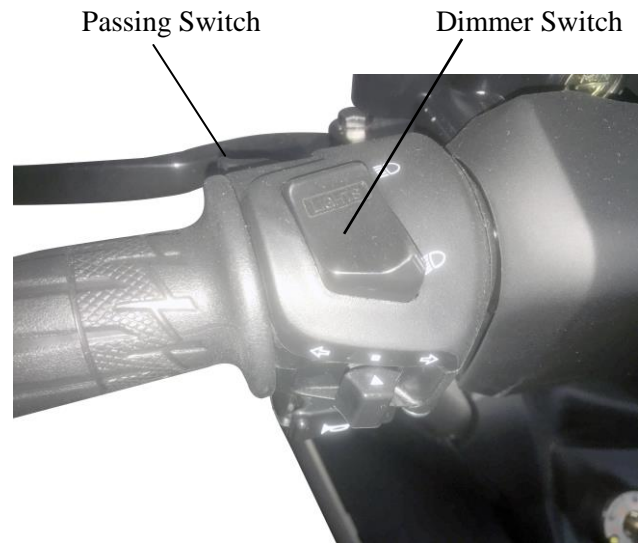

DIMMER & PASSING SW				
	HL	LO	HI	PASS
LO	○ — ○			
(N)	○ — ○ — ○			
HI	○ — ○ — ○			
PUSH	○ — ○		○ — ○	
CORD COLOR	L/W	W	L	B

WINKER SW			
	WR	R	L
L	○ — ○ — ○		
N			
R	○ — ○		
CORD COLOR	GR	SB	O

HORN SW		
	HO	BAT
FREE		
PUSH	○ — ○	
CORD COLOR	LG	B



Horn Switch

Turn Signal Switch



## 15. INSTRUMENT/SWITCHES/LIGHTS

### HORN INSPECTION

Remove the front cover .(⇒2-6)

Remove the floorboard. (⇒2-8)

Remove the inner cover. (⇒2-10)

Disconnect the horn wire couplers.

The horn is normal if it sounds when a 12V battery is connected across the horn wire terminals.

Install a new horn in the reverse order of removal.

Horn



### INSTRUMENTS

Remove the front cover .(⇒2-6)

Remove the inner cover .(⇒2-8)

Remove meter panel. (⇒2-9)

Remove the five screws.

Remove the Instruments.

Install a new horn in the reverse order of removal.

Instruments

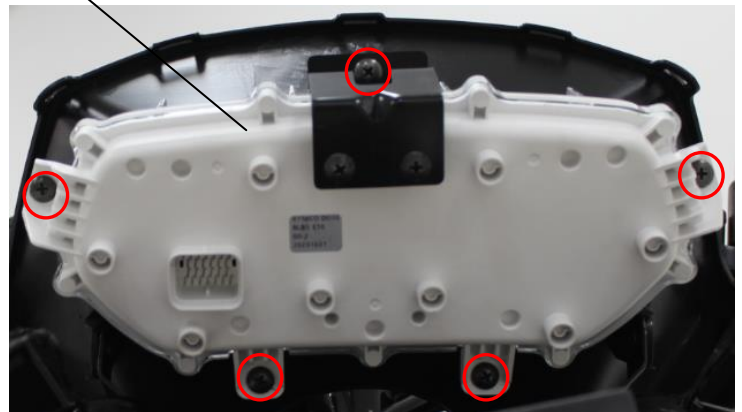

### HEADLIGHT/ FRONT TURN SIGNAL LIGHTS

#### REMOVAL/REPLACEMENT

Remove the front center cover (⇒2-3) .

Remove the left and right foot skirt (⇒2-3).

Remove the front cover(⇒2-3).

Remove the 11 screws attaching the front cover.

Remove and replacement the headlight.

\* •Headlight set need to be replaced as a set.

Headlight

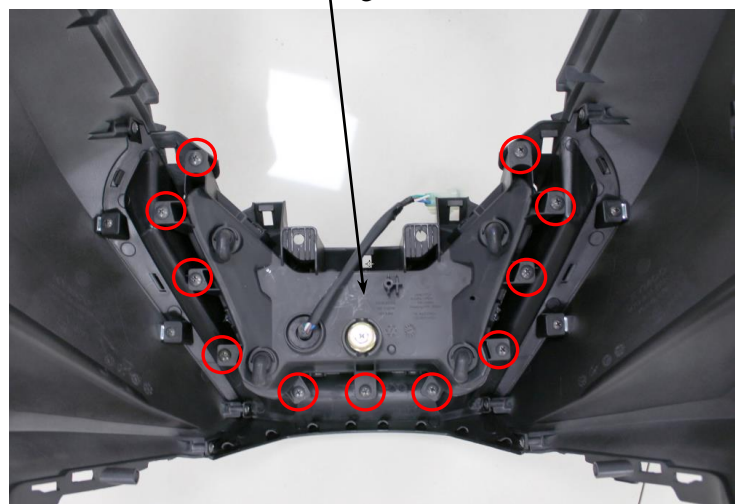

The installation sequence is the reverse of removal.



# 15. INSTRUMENT/SWITCHES/LIGHTS

## HEADLIGHT REALY

The Headlight is come on when the engine starts.

### INSPECTION

Turn the ignition switch to “ON”  
 Connect the multimeter (+) probe to the Black terminal and the multi-meter (-)probe to the Green terminal.  
 The voltage is the battery voltage.

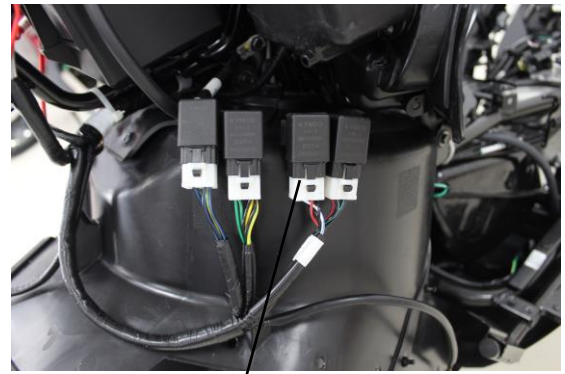

Headlight Realy

Starts the engine.

Connect the multimeter (+) probe to the white/Blue terminal and the multi-meter (-) probe to the Green terminal.  
 The voltage is the battery voltage.

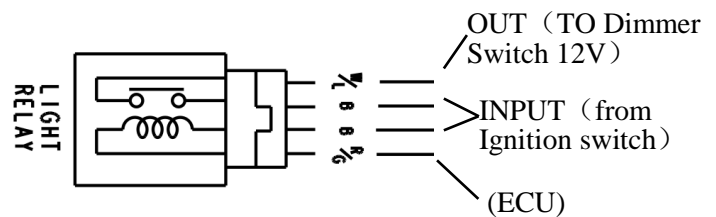

Taillight/brake light

## TAILLIGHT/BRAKE LIGHT

Remove the seat and met-in box (⇒2-4) .  
 Remove the center cover(⇒2-5).  
 Remove the rear carrier(⇒2-5).  
 Remove the rear center cover(⇒2-5).  
 Remove the rear fender(⇒2-5).  
 Remove the frame body cover(⇒2-6).  
 Remove the screws(red) and fasteners(blue) attaching the taillight/brake lights.  
 The installation sequence is the reverse of removal.



Rear turn signal light

## REAR TURN SIGNAL LIGHTS

Remove the nuts(yellow) attaching the rear turn signal lights.  
 Disconnect the rear turn signal lights connector.  
 Remove the rear turn signal lights.  
 The installation sequence is the reverse of removal.

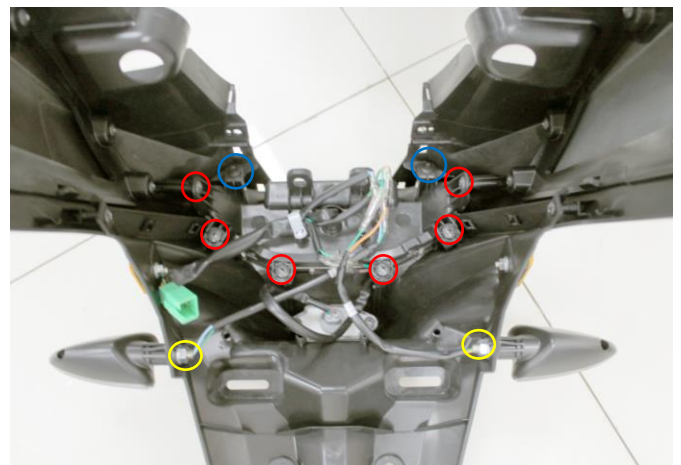

## **15. INSTRUMENT/SWITCHES/LIGHTS**

---

### **SIDE STAND SWITCH**

#### **INSPECTION**

Remove the luggage box.

Side stand switch is located on side stand.

Disconnect the side stand switch connector.

There should be continuity between the Yellow/Green and Green with the side stand is up.

There should be continuity between the Yellow/Black and Green with the side stand is down.

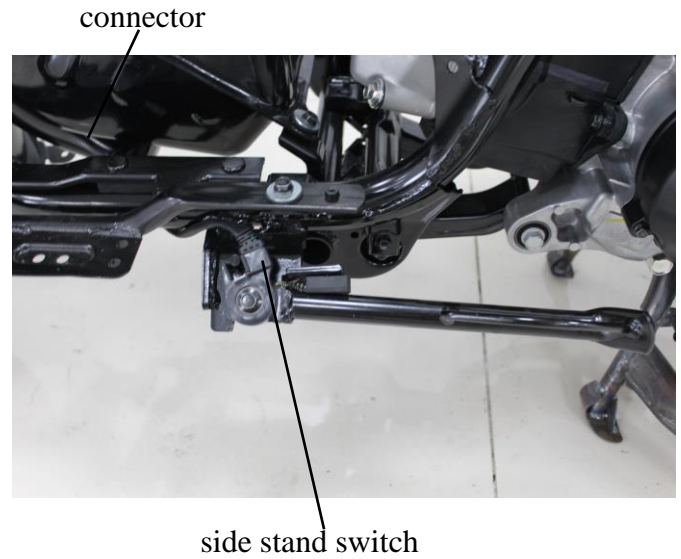

# 16. EVAPORATIVE EMISSION CONTROL SYSTEM

---

---

---

**16**

---

---

---

## EVAPORATIVE EMISSION CONTROL SYSTEM

---

SCHEMATIC DRAWING .....	16-1
EVAPORATIVE EMISSION CONTROL SYSTEM FUNCTION.....	16-2
TROUBLESHOOTING.....	16-2
SERVICE INFORMATION .....	16-3
PERGE CONTROL VALVE .....	16-4
CHARCOAL CANISTER.....	16-6

# 16. EVAPORATIVE EMISSION CONTROL SYSTEM

## SCHEMATIC DRAWING

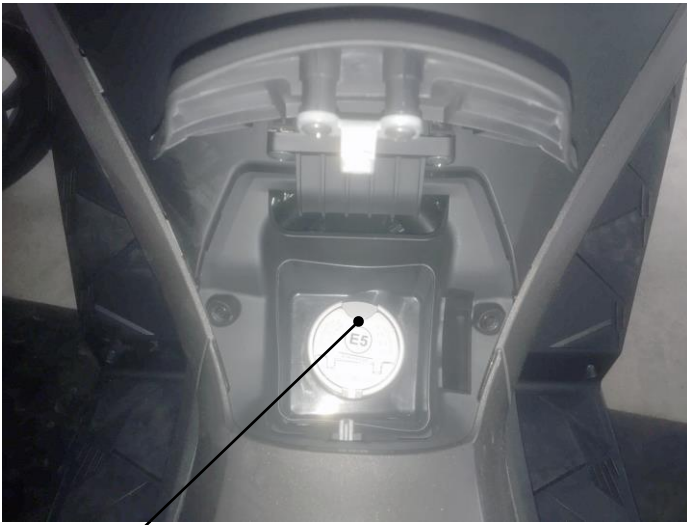

**Fuel tank cap**

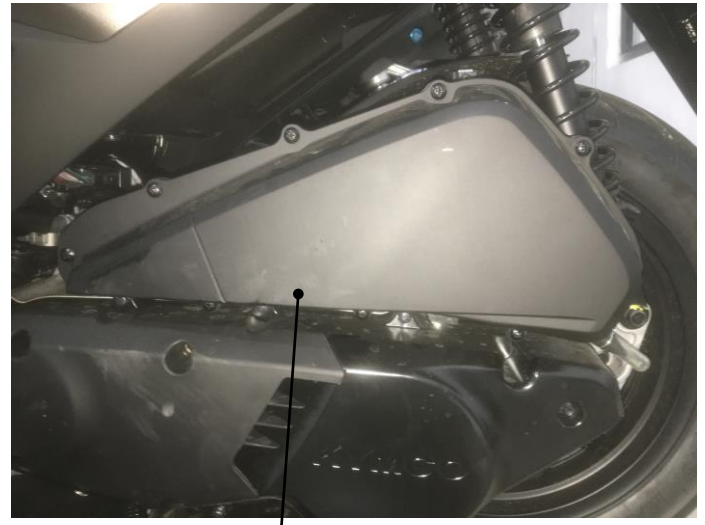

**Air Cleaner**

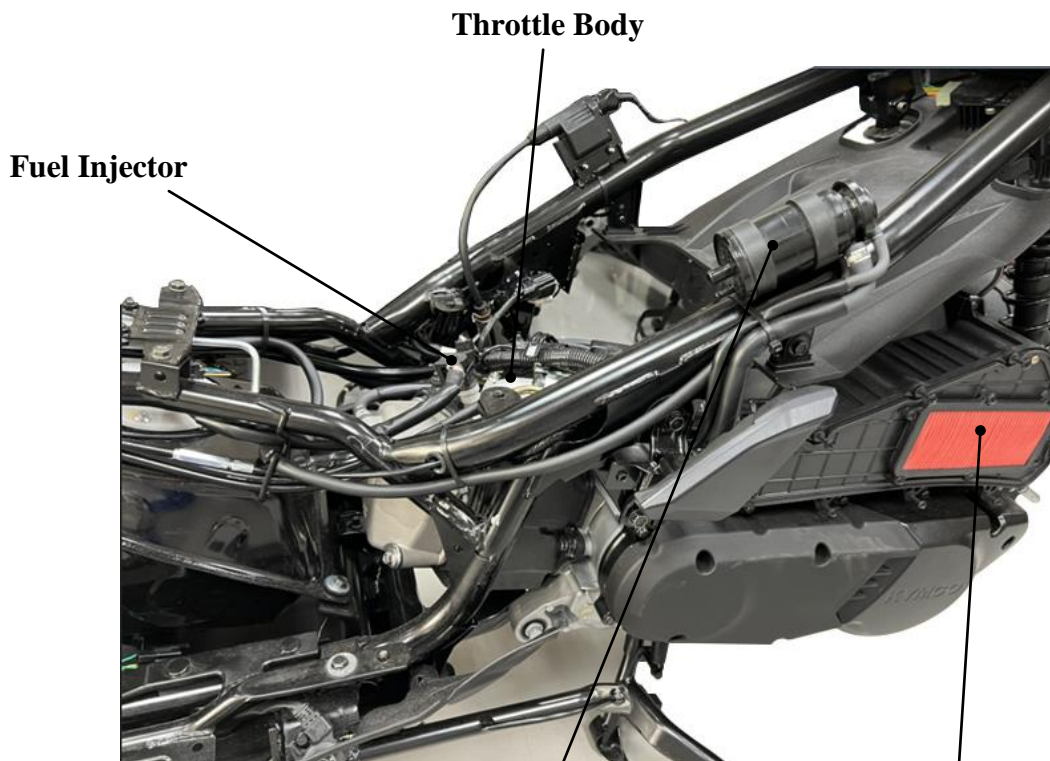

**Throttle Body**

**Fuel Injector**

**Charcoal Canister/ Purge Control Valve**

**Air Cleaner filter**

# 16. EVAPORATIVE EMISSION CONTROL SYSTEM

## EVAPORATIVE EMISSION CONTROL SYSTEM FUNCTION

### FOREWORD:

The Evaporative Emission Control System is abbreviated to E.E.C. System. This device collects the fuel vapor from the fuel tank and then the fuel vapor is drawn into the engine for re-burning to avoid air pollution caused by the fuel vapor diffused into the air.

### FUNCTION

Item	Purpose	Function
Purge Control Valve	Control vaporized HC from fuel tank not to diffuse into the air.	The charcoal canister absorbs vaporized HC from the fuel tank. When the engine is running and the purge control valve is open, the fuel vapor in the charcoal canister is drawn into the engine for re-burning.
Charcoal Canister	Absorb and store the vaporized HC from the fuel tank and carburetor.	The vaporized HC is absorbed in the charcoal canister and the specified volume of HC in the emission should not exceed 2g.
P.C.V. System	Completely recover the HC from blow-by gas in the crankcase for re-burning.	Through the P.C.V. system, the blow-by gas from the crankcase is separated into fuel vapor and fuel and then drawn into the cylinder for re-burning.

## TROUBLESHOOTING

### Engine loses power or runs erratic at idle speed

1. Clogged P.C.V. system
2. Clogged air cleaner
3. Faulty purge control valve
4. Loose or broken E.E.C. system tubes

### Engine idles or accelerates roughly

1. Faulty fuel cut-off valve
2. Faulty purge control valve
3. Clogged or faulty charcoal canister



## 16. EVAPORATIVE EMISSION CONTROL SYSTEM

### SERVICE INFORMATION

#### GENERAL INSTRUCTIONS

- Do not smoke or allow flames or sparks near the working area.
- Note the locations of tubes for proper installation.
- Replace any damaged tube with a new one.
- Make sure to tighten the connector of each tube securely.

#### TOOLS

- Vacuum pump – A937X – 014 – XXXX
- Pressure pump –

#### SPECIFICATIONS

Purge control valve vacuum pressure	45mm/Hg
Charcoal canister capacity	90cc

#### A. LEAKAGE TEST PIPING DIAGRAM

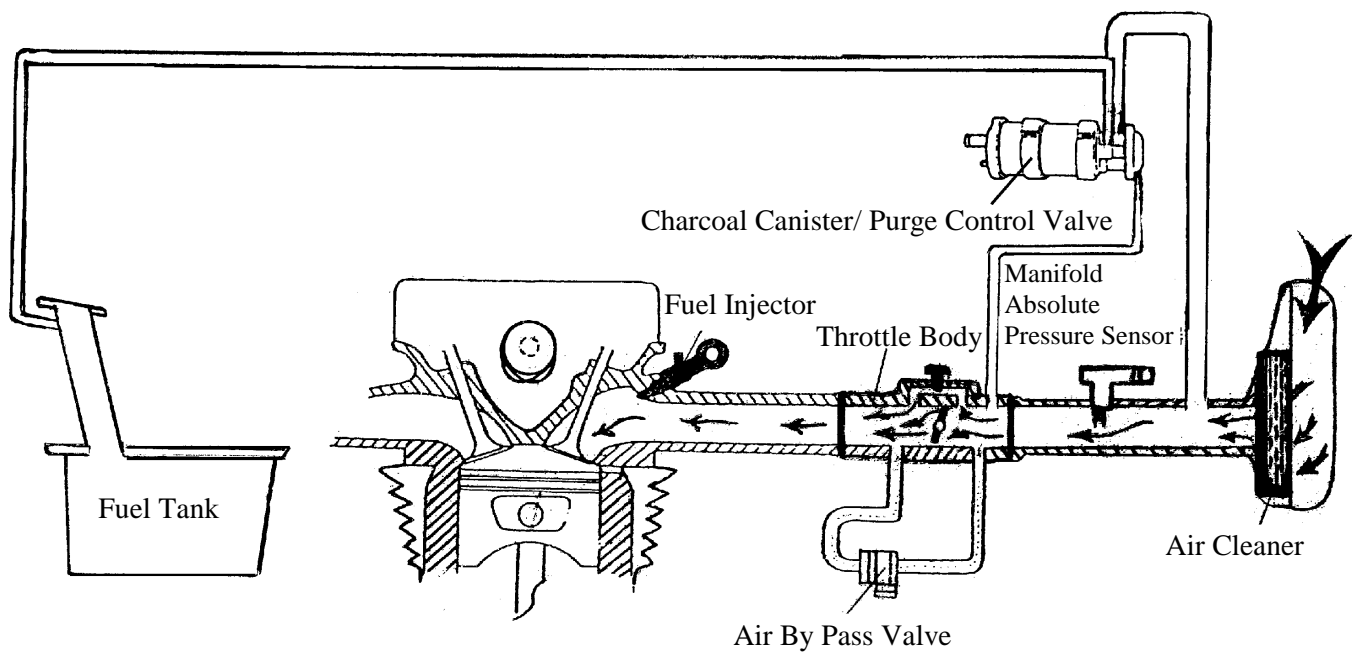

# 16. EVAPORATIVE EMISSION CONTROL SYSTEM

## PURGE CONTROL VALVE REMOVAL

1. Remove the front cover.
2. Disconnect the purge control valve vacuum tube that goes to the throttle body and the tubes that go to the air cleaner and charcoal canister. Remove the charcoal canister/purge control valve.

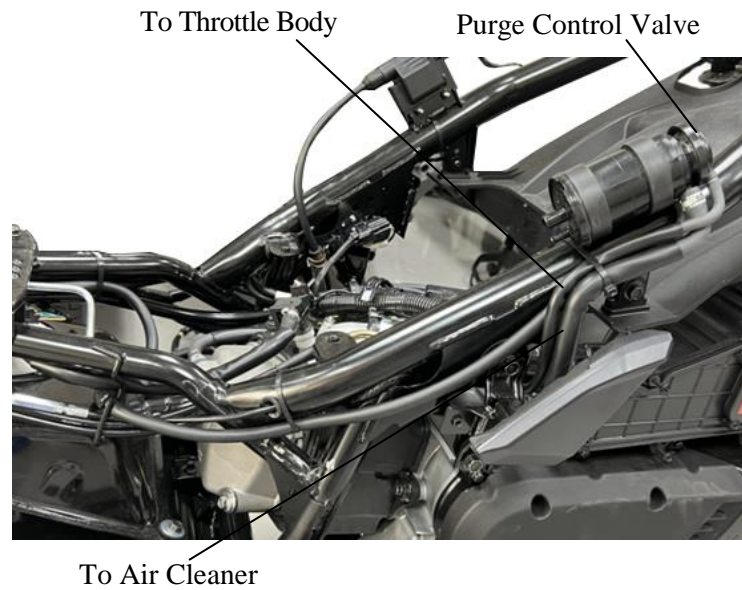

## INSPECTION

Connect a vacuum pump to the purge control valve tube that goes to the air cleaner and apply vacuum pressure of 250mm/Hg. The specified vacuum must be maintained for one minute. Replace the purge control valve with a new one if vacuum is not maintained.

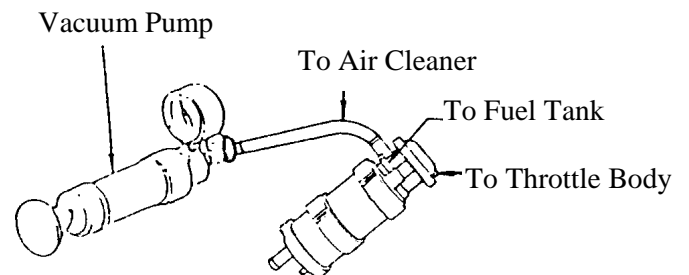

Connect a vacuum pump to the purge control valve tube that goes to the carburetor vacuum tube and apply vacuum pressure of 45mm/Hg. The specified vacuum must be maintained for one minute. Replace the purge control valve with a new one if vacuum is not maintained.

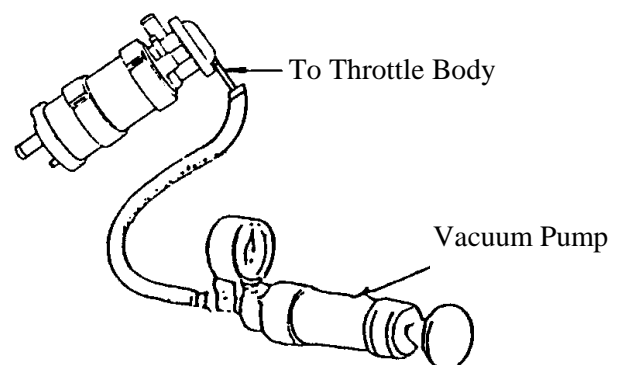

## 16. EVAPORATIVE EMISSION CONTROL SYSTEM

### PURGE CONTROL VALVE FLOW INSPECTION

1. Connect a vacuum pump to the purge control valve vacuum tube and apply vacuum pressure of 45mm/Hg.
2. Connect a pressure pump to the tube that goes to the charcoal canister and apply pressure. The flow must be over 9.4 liters per minute and replace the purge control valve with a new one if the specified flow is not reached.

\* To prevent damage to the purge control valve, do not use high air pressure sources. Use a hand operated pressure pump only.

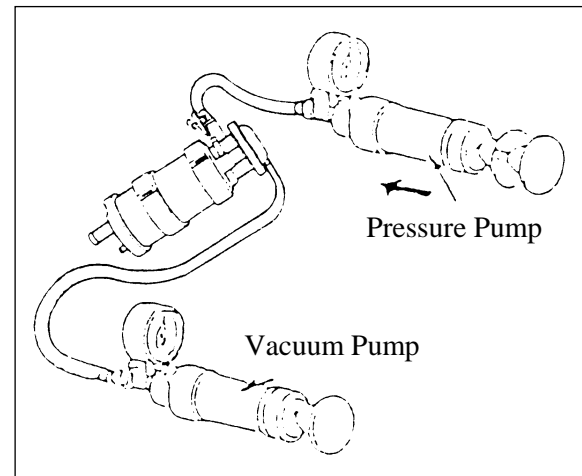

### INSTALLATION

1. Install the purge control valve in the reverse order of removal.
2. Route and reconnect the purge control valve tubes properly and securely.

\* Be careful not to bend, twist or kink the tubes during installation.

# 16. EVAPORATIVE EMISSION CONTROL SYSTEM

## CHARCOAL CANISTER

### REMOVAL

1. Remove the front cover.
2. Disconnect the charcoal canister tubes that go to the fuel tank and purge control valve.
3. Remove the charcoal canister.

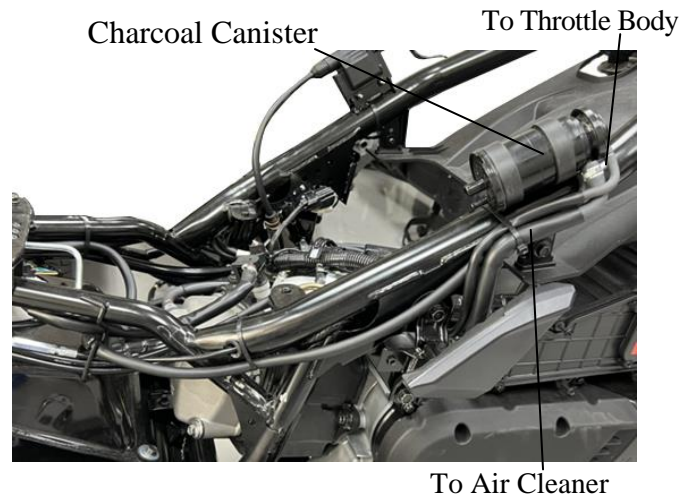

### INSPECTION

1. Plug the tube that goes to the fuel tank and plug the blow-by tube. Then connect a hose to the canister. Blow the hose with mouth. The charcoal canister is normal if air can be blown into it. If clogged, replace it with a new one.
2. Check the charcoal for cracks and replace if necessary.

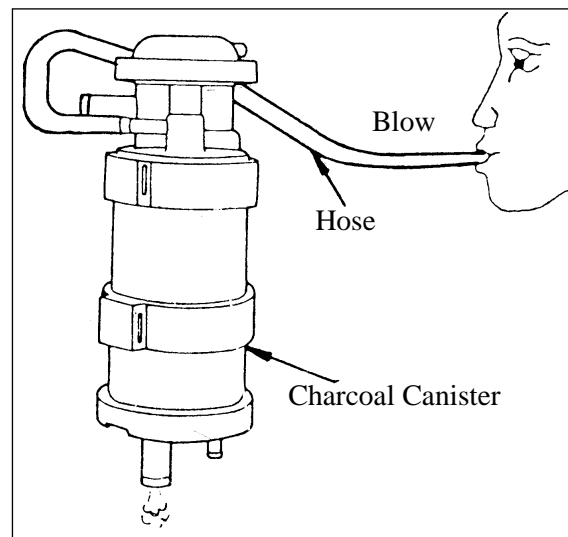

### INSTALLATION

Install the charcoal canister in the reverse order of removal.

**\***

- The charcoal canister must be installed to its original position to avoid affecting its performance.
- Do not bend, twist or kink the tubes during installation.